

EANCOM 2002 Syntax 3
Edition 2016_Update 2021

Incoice / Credit Note
(INVOIC)

Introduction.....	2
Branching Diagram	3
Message Structure.....	15
Segmentlayout.....	18
Codes	135
Example.....	498

Einführung

Introduction

The following message specification is based on the publication of the "Incoice / Credit Note Message" of GS1 Global in syntax 3.

Status

MESSAGE TYPE: INVOIC
REFERENCE DIRECTORY: D.01B
EANCOM® SUBSET VERSION: 011

Definition

A message claiming payment for goods or services supplied under conditions agreed between the seller and the buyer.

The United Nations Standard Invoice Message, with correct data qualification, serves also as the specification for Debit Note and Credit Note messages.

Throughout this document, the reference to 'Invoice' may be interpreted as conveying the wider meaning of 'Invoice/Credit Note/Debit Note'.

Principles

A seller may invoice for one or more transactions

An invoice may refer to goods, items or services related to one or more orders, delivery instructions, call-offs, etc...

An invoice may contain references to payment terms.

An invoice for cross border transactions may contain additional information for customs and/or statistical purposes/services.

An invoice may contain transport details.

Branching Diagram

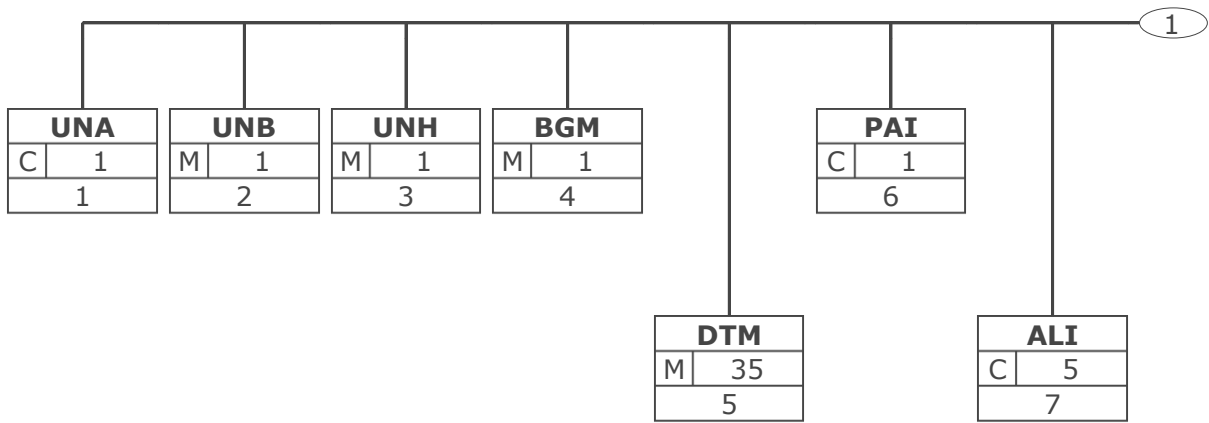

Tag	Tag = Segment/Group Tag
St MaxOcc	St = Status (M=Mandatory, C=Conditional, R=Required, O=Optional, A=Advised, D=Dependent)
No	MaxOcc = Maximum occurrence of the segment/group; No = Consecutive segment number

Branching Diagram

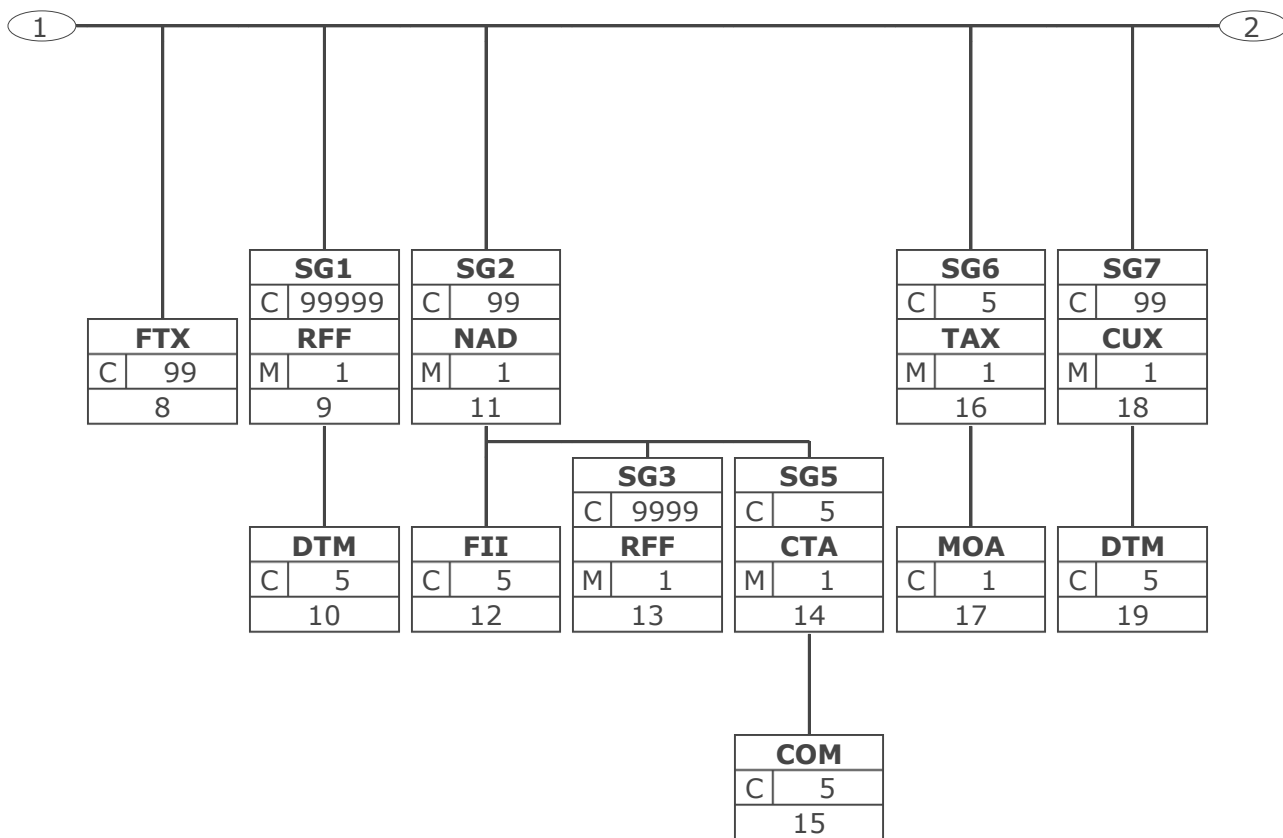

Tag	Tag = Segment/Group Tag
St MaxOcc	St = Status (M=Mandatory, C=Conditional, R=Required, O=Optional, A=Advised, D=Dependent)
No	MaxOcc = Maximum occurrence of the segment/group; No = Consecutive segment number

Branching Diagram

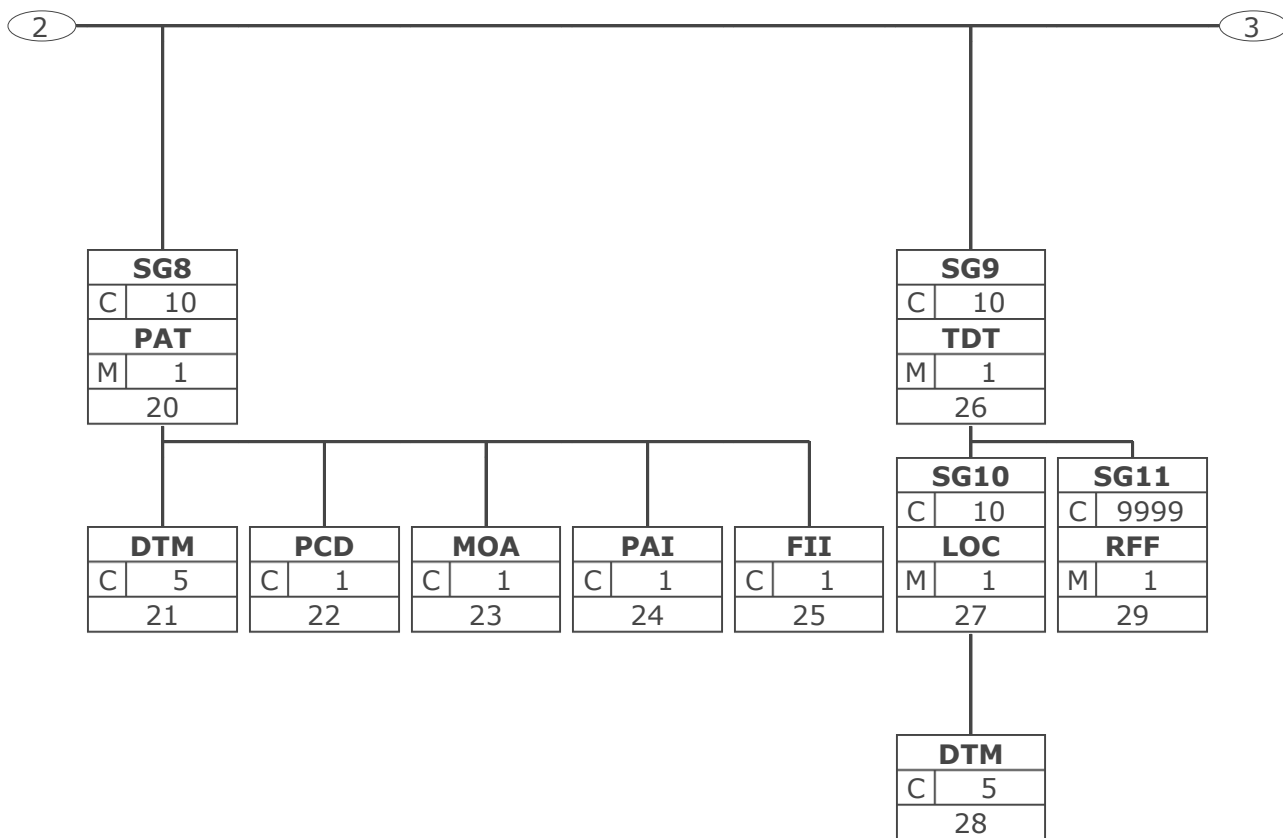

Tag	Tag = Segment/Group Tag	
St	MaxOcc	St = Status (M=Mandatory, C=Conditional, R=Required, O=Optional, A=Advised, D=Dependent)
No	MaxOcc	MaxOcc = Maximum occurrence of the segment/group; No = Consecutive segment number

Branching Diagram

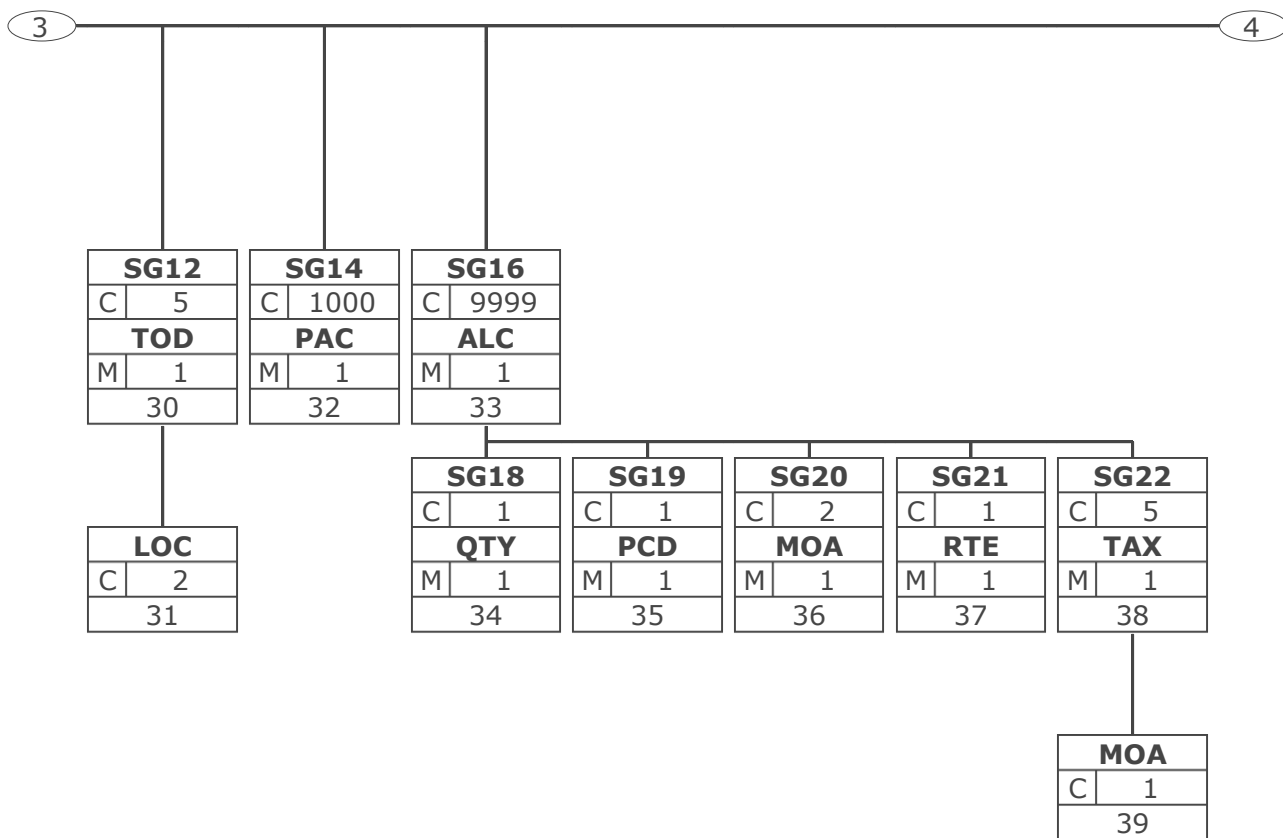

Tag	Tag = Segment/Group Tag
St MaxOcc	St = Status (M=Mandatory, C=Conditional, R=Required, O=Optional, A=Advised, D=Dependent)
No	MaxOcc = Maximum occurrence of the segment/group; No = Consecutive segment number

Branching Diagram

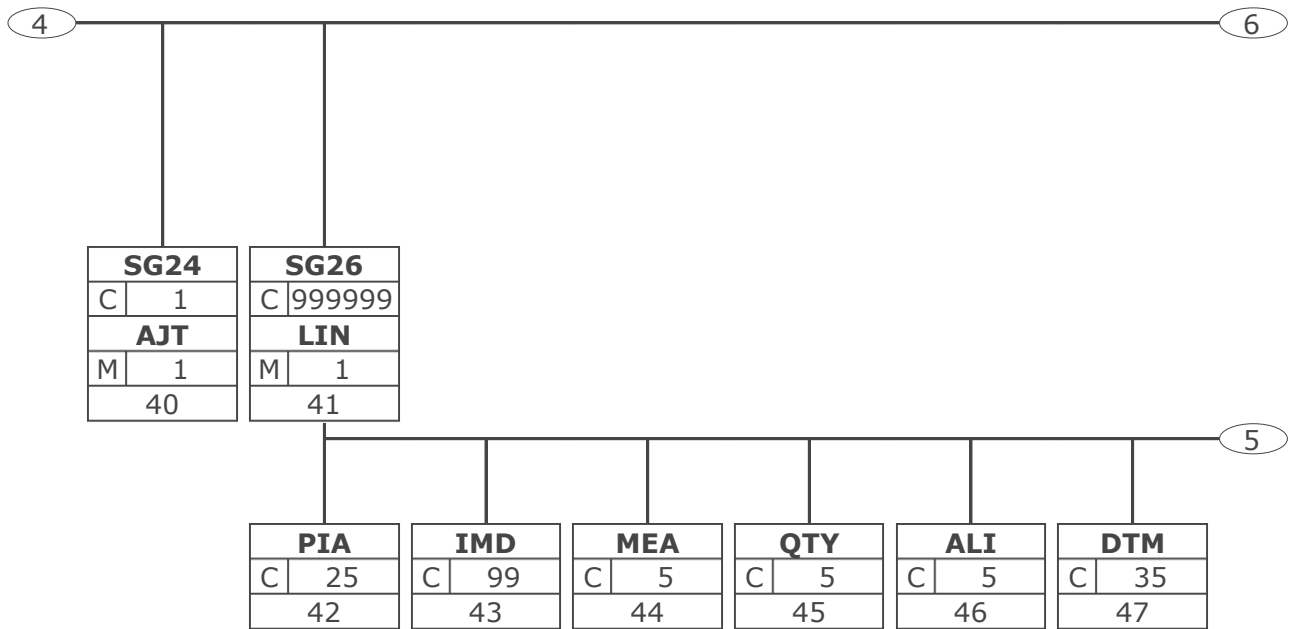

Tag	Tag = Segment/Group Tag
St MaxOcc	St = Status (M=Mandatory, C=Conditional, R=Required, O=Optional, A=Advised, D=Dependent)
No	MaxOcc = Maximum occurrence of the segment/group; No = Consecutive segment number

Branching Diagram

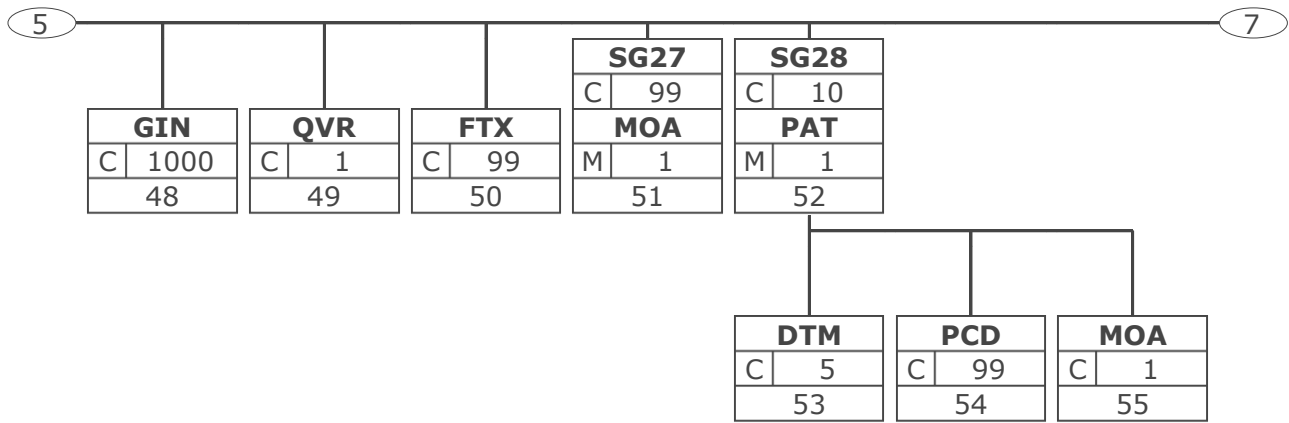

Tag	Tag = Segment/Group Tag	
St	MaxOcc	St = Status (M=Mandatory, C=Conditional, R=Required, O=Optional, A=Advised, D=Dependent)
No	MaxOcc = Maximum occurrence of the segment/group; No = Consecutive segment number	

Branching Diagram

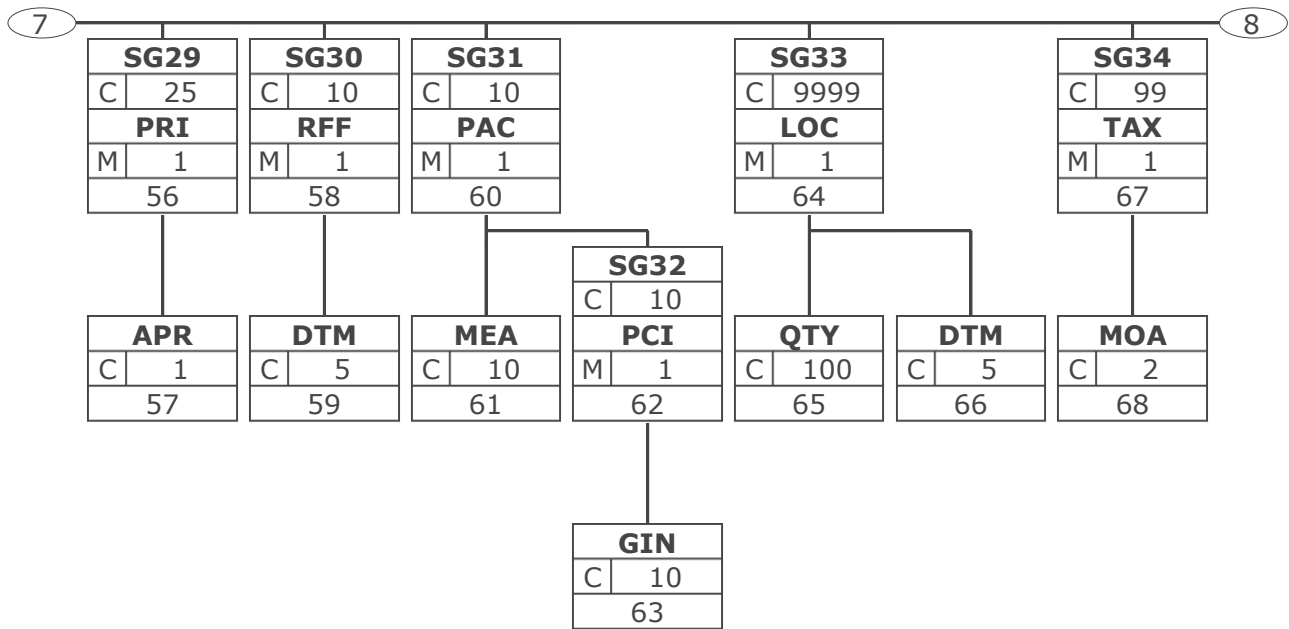

Tag	Tag = Segment/Group Tag
St	St = Status (M=Mandatory, C=Conditional, R=Required, O=Optional, A=Advised, D=Dependent)
No	MaxOcc = Maximum occurrence of the segment/group; No = Consecutive segment number

Branching Diagram

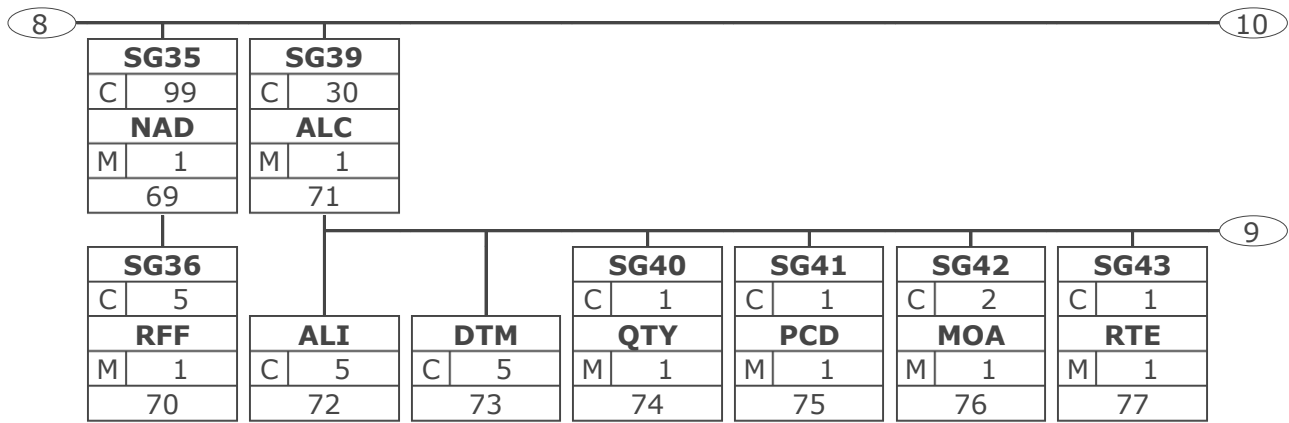

Tag	Tag = Segment/Group Tag
St MaxOcc	St = Status (M=Mandatory, C=Conditional, R=Required, O=Optional, A=Advised, D=Dependent)
No	MaxOcc = Maximum occurrence of the segment/group; No = Consecutive segment number

Branching Diagram

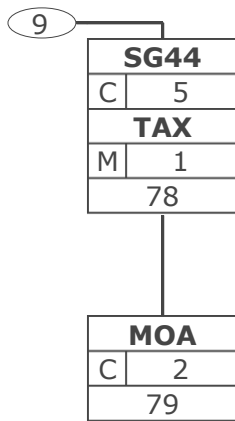

Tag	Tag = Segment/Group Tag
St MaxOcc	St = Status (M=Mandatory, C=Conditional, R=Required, O=Optional, A=Advised, D=Dependent)
No	MaxOcc = Maximum occurrence of the segment/group; No = Consecutive segment number

Branching Diagram

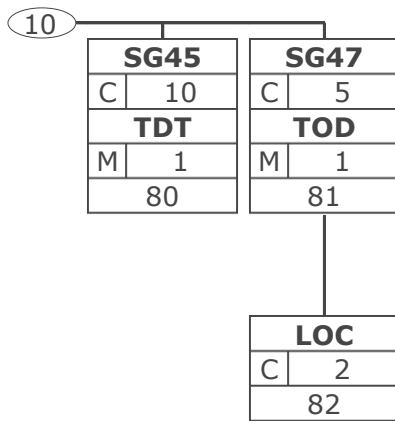

Tag	Tag = Segment/Group Tag
St MaxOcc	St = Status (M=Mandatory, C=Conditional, R=Required, O=Optional, A=Advised, D=Dependent)
No	MaxOcc = Maximum occurrence of the segment/group; No = Consecutive segment number

Branching Diagram

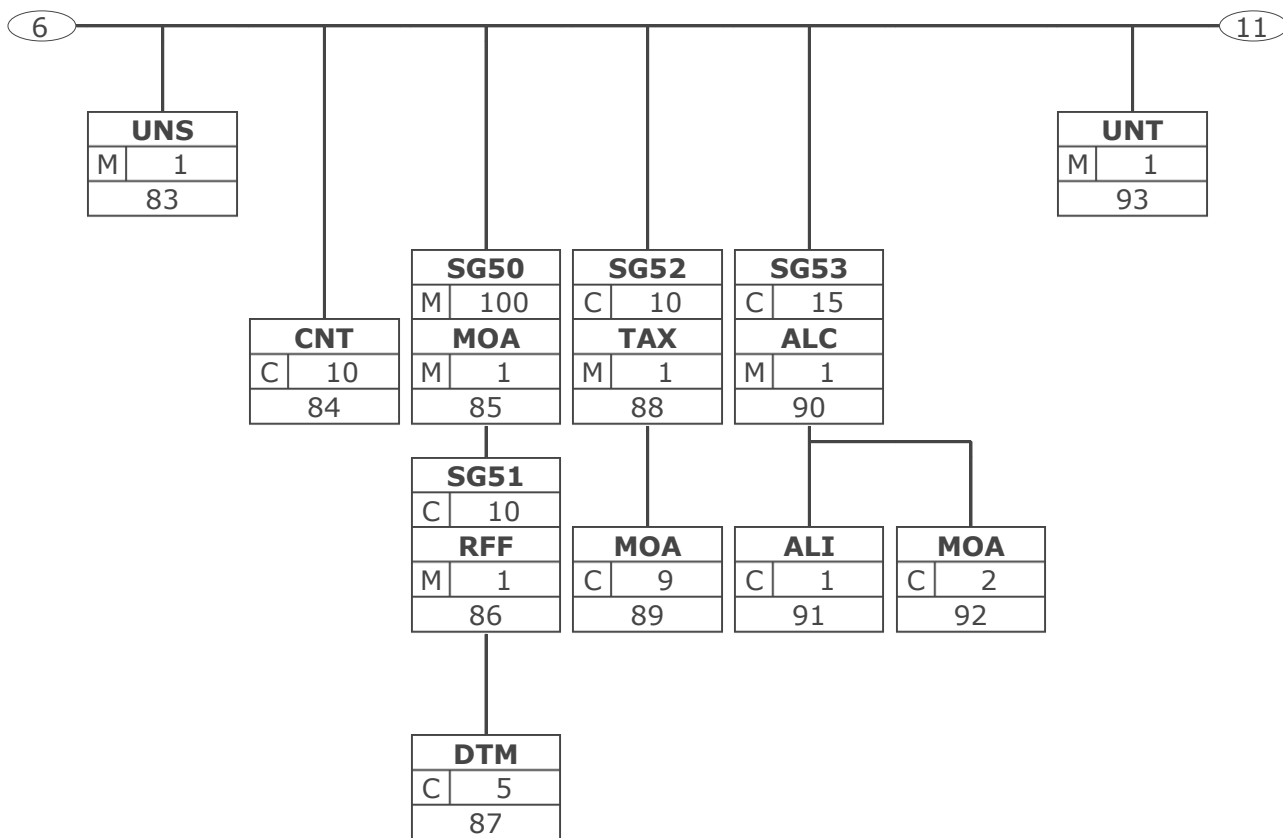

Tag	Tag = Segment/Group Tag
St MaxOcc	St = Status (M=Mandatory, C=Conditional, R=Required, O=Optional, A=Advised, D=Dependent)
No	MaxOcc = Maximum occurrence of the segment/group; No = Consecutive segment number

Branching Diagram

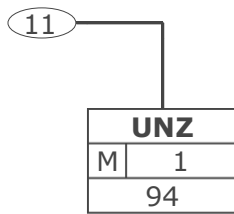

Tag	Tag = Segment/Group Tag
St	MaxOcc St = Status (M=Mandatory, C=Conditional, R=Required, O=Optional, A=Advised, D=Dependent)
No	MaxOcc = Maximum occurrence of the segment/group; No = Consecutive segment number

Message Structure

Seg.	No.	Status	Max Occ	Segment
UNA	1	C	1	Service string advice
UNB	2	M	1	Interchange header
Invoice Heading Section				
UNH	3	M	1	Message header
BGM	4	M	1	Beginning of message
DTM	5	M	35	Date/time/period
PAI	6	C	1	Payment instructions
ALI	7	C	5	Additional information
FTX	8	C	99	Free text
SG1		C	99999	RFF-DTM
RFF	9	M	1	Reference
DTM	10	C	5	Date/time/period
SG2		C	99	NAD-FII-SG3-SG5
NAD	11	M	1	Name and address
FII	12	C	5	Financial institution information
SG3		C	9999	RFF
RFF	13	M	1	Reference
SG5		C	5	CTA-COM
CTA	14	M	1	Contact information
COM	15	C	5	Communication contact
SG6		C	5	TAX-MOA
TAX	16	M	1	Duty/tax/fee details
MOA	17	C	1	Monetary amount
SG7		C	99	CUX-DTM
CUX	18	M	1	Currencies
DTM	19	C	5	Date/time/period
SG8		C	10	PAT-DTM-PCD-MOA-PAI-FII
PAT	20	M	1	Payment terms basis
DTM	21	C	5	Date/time/period
PCD	22	C	1	Percentage details
MOA	23	C	1	Monetary amount
PAI	24	C	1	Payment instructions
FII	25	C	1	Financial institution information
SG9		C	10	TDT-SG10-SG11
TDT	26	M	1	Details of transport
SG10		C	10	LOC-DTM
LOC	27	M	1	Place/location identification
DTM	28	C	5	Date/time/period
SG11		C	9999	RFF
RFF	29	M	1	Reference
SG12		C	5	TOD-LOC
TOD	30	M	1	Terms of delivery or transport
LOC	31	C	2	Place/location identification
SG14		C	1000	PAC
PAC	32	M	1	Package
SG16		C	9999	ALC-SG18-SG19-SG20-SG21-SG22
ALC	33	M	1	Allowance or charge
SG18		C	1	QTY
QTY	34	M	1	Quantity
SG19		C	1	PCD
PCD	35	M	1	Percentage details

Max. Occ. = Maximum occurrence of the segment/group, Status: M=Mandatory, C=Conditional, R=Required, O=Optional, A=Advised, D=Dependent

Message Structure

Seg.	No.	Status	Max Occ	Segment
SG20		C	2	MOA
MOA	36	M	1	Monetary amount
SG21		C	1	RTE
RTE	37	M	1	Rate details
SG22		C	5	TAX-MOA
TAX	38	M	1	Duty/tax/fee details
MOA	39	C	1	Monetary amount
SG24		C	1	AJT
AJT	40	M	1	Adjustment details
Invoice Detail Section				
SG26		C	9999999	LIN-PIA-IMD-MEA-QTY-ALI-DTM-GIN-QVR-FTX-SG27-SG28-SG29-SG30-SG31-SG33-SG34-SG35-SG39-SG45-SG47
LIN	41	M	1	Line item
PIA	42	C	25	Additional product id
IMD	43	C	99	Item description
MEA	44	C	5	Measurements
QTY	45	C	5	Quantity
ALI	46	C	5	Additional information
DTM	47	C	35	Date/time/period
GIN	48	C	1000	Goods identity number
QVR	49	C	1	Quantity variances
FTX	50	C	99	Free text
SG27		C	99	MOA
MOA	51	M	1	Monetary amount
SG28		C	10	PAT-DTM-PCD-MOA
PAT	52	M	1	Payment terms basis
DTM	53	C	5	Date/time/period
PCD	54	C	99	Percentage details
MOA	55	C	1	Monetary amount
SG29		C	25	PRI-APR
PRI	56	M	1	Price details
APR	57	C	1	Additional price information
SG30		C	10	RFF-DTM
RFF	58	M	1	Reference
DTM	59	C	5	Date/time/period
SG31		C	10	PAC-MEA-SG32
PAC	60	M	1	Package
MEA	61	C	10	Measurements
SG32		C	10	PCI-GIN
PCI	62	M	1	Package identification
GIN	63	C	10	Goods identity number
SG33		C	9999	LOC-QTY-DTM
LOC	64	M	1	Place/location identification
QTY	65	C	100	Quantity
DTM	66	C	5	Date/time/period
SG34		C	99	TAX-MOA
TAX	67	M	1	Duty/tax/fee details
MOA	68	C	2	Monetary amount
SG35		C	99	NAD-SG36

Max. Occ. = Maximum occurrence of the segment/group, Status: M=Mandatory, C=Conditional, R=Required, O=Optional, A=Advised, D=Dependent

Message Structure

Seg.	No.	Status	Max Occ	Segment
NAD	69	M	1	Name and address
SG36		C	5	RFF
RFF	70	M	1	Reference
SG39		C	30	ALC-ALI-DTM-SG40-SG41-SG42-SG43-SG44
ALC	71	M	1	Allowance or charge
ALI	72	C	5	Additional information
DTM	73	C	5	Date/time/period
SG40		C	1	QTY
QTY	74	M	1	Quantity
SG41		C	1	PCD
PCD	75	M	1	Percentage details
SG42		C	2	MOA
MOA	76	M	1	Monetary amount
SG43		C	1	RTE
RTE	77	M	1	Rate details
SG44		C	5	TAX-MOA
TAX	78	M	1	Duty/tax/fee details
MOA	79	C	2	Monetary amount
SG45		C	10	TDT
TDT	80	M	1	Details of transport
SG47		C	5	TOD-LOC
TOD	81	M	1	Terms of delivery or transport
LOC	82	C	2	Place/location identification

Invoice Summary Section

UNS	83	M	1	Section control
CNT	84	C	10	Control total
SG50		M	100	MOA-SG51
MOA	85	M	1	Monetary amount
SG51		C	10	RFF-DTM
RFF	86	M	1	Reference
DTM	87	C	5	Date/time/period
SG52		C	10	TAX-MOA
TAX	88	M	1	Duty/tax/fee details
MOA	89	C	9	Monetary amount
SG53		C	15	ALC-ALI-MOA
ALC	90	M	1	Allowance or charge
ALI	91	C	1	Additional information
MOA	92	C	2	Monetary amount
UNT	93	M	1	Message trailer
UNZ	94	M	1	Interchange trailer

Max. Occ. = Maximum occurrence of the segment/group, Status: M=Mandatory, C=Conditional, R=Required, O=Optional, A=Advised, D=Dependent

Segment Layout

No. Seg	St	Max. Occ.				
1	UNA	C 1	Service string advice To define the characters selected for use as delimiters and indicators in the rest of the interchange that follows.			
Business Term	DE	EDIFACT	Format	St	*	Description
	UNA1	Component data element separator	an1	M	*	Used as a separator between component data elements contained within a composite data element (default value: ":")
	UNA2	Data element separator	an1	M	*	Used to separate two simple or composite data elements (default value: "+")
	UNA3	Decimal notation	an1	M	*	Used to indicate the character used for decimal notation (default value: ".")
	UNA4	Release indicator	an1	M	*	Used to restore any service character to its original specification (value: "?").
	UNA5	Reserved for future use	an1	M	*	(default value: space)
	UNA6	Segment terminator	an1	M	*	Used to indicate the end of segment data (default value: "'")
<p>The service string advice shall begin with the upper case characters UNA immediately followed by six characters in the order shown below. The same character shall not be used in more than one position of the UNA.</p> <p>This segment is used to inform the receiver of the interchange that a set of service string characters which are different to the default characters are being used.</p> <p>When using the default set of service characters, the UNA segment need not be sent. If it is sent, it must immediately precede the UNB segment and contain the four service string characters (positions UNA1, UNA2, UNA4 and UNA6) selected by the interchange sender.</p> <p>Regardless of whether or not all of the service string characters are being changed every data element within this segment must be filled, (i.e., if some default values are being used with user defined ones, both the default and user defined values must be specified).</p> <p>When expressing the service string characters in the UNA segment, it is not necessary to include any element separators.</p> <p>The use of the UNA segment is required when using a character set other than level A.</p> <p>Example: UNA:+.?' '</p> <p>Example: UNA:+.?' '</p>						

Max. Occ. = Maximum Occurrence, St = Status, * = Restricted Codes
 Status: M=Mandatory, R=Required, O=Optional, C=Conditional, D=Dependent, A=Advised, N=Not used

Segment Layout

No. Seg	St	Max. Occ.			
2	UNB	M 1	Interchange header To start, identify and specify an interchange.		
Business Term	DE	EDIFACT	Format	St	* Description
	S001	Syntax identifier		M	See Part I chapter 5.2.7 and segment notes.
	0001	Syntax identifier	a4	M	* UNOA UN/ECE level A UNOB UN/ECE level B UNOC UN/ECE level C UNOD UN/ECE level D UNOE UN/ECE level E UNOF UN/ECE level F
	0002	Syntax version number	n1	M	* 3 Version 3
	S002	Interchange sender		M	
	0004	Sender identification	an..35	M	GLN (n13)
	0007	Partner identification code qualifier	an..4	R	* 14 GS1
	0008	Address for reverse routing	an..14	O	
	S003	Interchange recipient		M	
	0010	Recipient identification	an..35	M	GLN (n13)
	0007	Partner identification code qualifier	an..4	R	* 14 GS1
	0014	Routing address	an..14	O	
	S004	Date/time of preparation		M	
	0017	Date of preparation	n6	M	YYMMDD
	0019	Time of preparation	n4	M	HHMM
	0020	Interchange control reference	an..14	M	Unique reference identifying the interchange. Created by the interchange sender.
	S005	Recipient's reference, password		O	
	0022	Recipient's reference/ password	an..14	M	
	0025	Recipient's reference/ password qualifier	an2	O	
	0026	Application reference	an..14	O	Message identification if the interchange contains only one type of message.
	0029	Processing priority code	a1	O	A Highest priority
	0031	Acknowledgement request	n1	O	1 Requested
	0032	Communications agreement ID	an..35	O	* EANCOM.....
	0035	Test indicator	n1	O	1 Interchange is a test

Max. Occ. = Maximum Occurrence, St = Status, * = Restricted Codes
 Status: M=Mandatory, R=Required, O=Optional, C=Conditional, D=Dependent, A=Advised, N=Not used

Segment Layout

This segment is used to envelope the interchange, as well as to identify both, the party to whom the interchange is sent and the party who has sent the interchange. The principle of the UNB segment is the same as a physical envelope which covers one or more letters or documents, and which details, both the address where delivery is to take place and the address from where the envelope has come.

S001: The character encoding specified in basic code table of ISO/IEC 646 (7-bit coded character set for information interchange) shall be used for the interchange service string advice (if used) and up to and including the composite data element S001 'Syntax identifier' in the interchange header. The character repertoire used for the characters in an interchange shall be identified from the code value of data element 0001 in S001 'Syntax identifier' in the interchange header. The character repertoire identified does not apply to objects and/or encrypted data.

The default encoding technique for a particular repertoire shall be the encoding technique defined by its associated character set specification.

DE 0001: The recommended (default) character set for use in EANCOM® for international exchanges is character set A (UNOA). Should users wish to use character sets other than A, an agreement on which set to use should be reached on a bilateral basis before communications begin.

DE 0004, 0008, 0010, 0014, 0042 and 0046: Within EANCOM® the use of the Global Location Number (GLN) is recommended for the identification of the interchange sender and recipient.

DE 0008: Identification (e.g. a division) specified by the sender of the interchange, to be included if agreed, by the recipient in response interchanges, to facilitate internal routing.

DE 0042: Sub-level of sender internal identification, when further sub-level identification is required.

DE 0014: The address for routing, provided beforehand by the interchange recipient, is used by the interchange sender to inform the recipient of the internal address, within the latter's systems, to which the interchange should be routed. It is recommended that the GLN be used for this purpose.

DE 0007: Identification (e.g. a division) specified by the recipient of the interchange, to be included if agreed, by the sender in response interchanges, to facilitate internal routing.

DE 0046: Sub-level of recipient internal identification, when further sub-level identification is required.

DE S004: The date and time specified in this composite should be the date and time at which the interchange sender prepared the interchange. This date and time may not necessarily be the same as the date and time of contained messages.

DE 0020: The interchange control reference number is generated by the interchange sender and is used to identify uniquely each interchange. Should the interchange sender wish to re-use interchange control reference numbers, it is recommended that each number be preserved for at least a period of three months before being re-used. In order to guarantee uniqueness, the interchange control reference number should always be linked to the interchange sender's identification (DE 0004).

DE S005: The use of passwords must first be agreed bilaterally by the parties exchanging the interchange.

DE 0026: This data element is used to identify the application, on the interchange recipient's system, to which the interchange is directed. This data element may only be used if the interchange contains only one type of message, (e.g. only invoices). The reference used in this data element is assigned by the interchange sender.

DE 0031: This data element is used to indicate whether an acknowledgement to the interchange is required. The EANCOM® APERAK or CONTRL message should be used to provide acknowledgement of interchange receipt. In addition, the EANCOM® CONTRL message may be used to indicate when an interchange has been rejected due to syntax errors.

DE 0032: This data element is used to identify any underlying agreements which control the exchange of data. Within EANCOM®, the identity of such agreements must start with the letters 'EANCOM', the remaining characters within the data element being filled according to bilateral

Max. Occ. = Maximum Occurrence, St = Status, * = Restricted Codes

Status: M=Mandatory, R=Required, O=Optional, C=Conditional, D=Dependent, A=Advised, N=Not used

Segment Layout

agreements.

Example: UNB+UNOA:3+4012345000009:14:1+4000004000002:14:4000004000099+021013:1043+12345555+
REF:AA++A+1+EANCOM-DISI+1'

Example: UNB+UNOA:3+5412345678908:14+8798765432106:14+020102:1000+12345555+++++EANCOMREF
52'

Max. Occ. = Maximum Occurrence, St = Status, * = Restricted Codes

Status: M=Mandatory, R=Required, O=Optional, C=Conditional, D=Dependent, A=Advised, N=Not used

Segment Layout

No. Seg	St	Max. Occ.				
3	UNH	M 1	Message header			To head, identify and specify a message.
Business Term	DE	EDIFACT	Format	St	*	Description
	0062	Message reference number	an..14	M		Sender's unique message reference. Sequence number of messages in the interchange. DE 0062 in UNT will have the same value. Generated by the sender.
	S009	Message identifier		M		
	0065	Message type	an..6	M	*	INVOIC Invoice message
	0052	Message version number	an..3	M	*	D Draft version/ UN/EDIFACT Directory
	0054	Message release number	an..3	M	*	01B Release 2001 - B
	0051	Controlling agency	an..2	M	*	UN UN/CEFACT
	0057	Association assigned code	an..6	R	*	EAN011 GS1 version control number (GS1 Permanent Code)
<p>This segment is used to head, identify and specify a message. DE's 0065, 0052, 0054, and 0051: Indicate that the message is a UNSM Invoice based on the D. 01B directory under the control of the United Nations. Example: Example: UNH+1+INVOIC:D:01B:UN:EAN011' Example: UNH+1+INVOIC:D:01B:UN:EAN011'</p>						

Max. Occ. = Maximum Occurrence, St = Status, * = Restricted Codes
 Status: M=Mandatory, R=Required, O=Optional, C=Conditional, D=Dependent, A=Advised, N=Not used

Segment Layout

No. Seg	St	Max. Occ.				
4	BGM	M 1	Beginning of message To indicate the type and function of a message and to transmit the identifying number.			
Business Term	DE	EDIFACT	Format	St	* Description	
	C002	Document/message name		R		
	1001	Document name code	an..3	R	* 67 Commercial dispute 82 Metered services invoice 83 Credit note related to financial adjustments 84 Debit note related to financial adjustments 130 Invoicing data sheet 325 Proforma invoice 380 Commercial invoice 381 Credit note - goods and services 382 Commission note 383 Debit note - goods and services 384 Corrected invoice 385 Consolidated invoice 386 Prepayment invoice 388 Tax invoice 389 Self-billed invoice 390 Delcredere invoice 393 Factored invoice 261 Self billed credit note 262 Consolidated credit note - goods and services 308 Delcredere credit note 527 Self billed debit note	
	1131	Code list identification code	an..17	N		
	3055	Code list responsible agency code	an..3	N		

Max. Occ. = Maximum Occurrence, St = Status, * = Restricted Codes
 Status: M=Mandatory, R=Required, O=Optional, C=Conditional, D=Dependent, A=Advised, N=Not used

Segment Layout

Business Term	DE	EDIFACT	Format	St	*	Description
	1000	Document name	an..35	O		
	C106	Document/message identification		R		
	1004	Document identifier	an..35	R		Invoice Number assigned by document sender.
	1056	Version identifier	an..9	N		
	1060	Revision identifier	an..6	O		
	1225	Message function code	an..3	R	*	1 Cancellation 5 Replace 7 Duplicate 9 Original 31 Copy 43 Additional transmission 55 Notification only
	4343	Response type code	an..3	O	*	AB Message acknowledgement NA No acknowledgement needed

This segment is used to indicate the type and function of a message and to transmit the identifying number.

Example:

This example identifies the document as being an original commercial invoice using the code value 380. The document has the reference number 432097.

This example identifies the document as being a metered services invoice using the code value 82. The document has the reference number MSI5422.

Example: BGM+380:::METERED SERVICES INVOICE.+432097:::X+9+NA'

Example: BGM+380+432097+9'

Example: BGM+82+MSI5422'

Max. Occ. = Maximum Occurrence, St = Status, * = Restricted Codes

Status: M=Mandatory, R=Required, O=Optional, C=Conditional, D=Dependent, A=Advised, N=Not used

Segment Layout

No.	Seg	St	Max. Occ.			
5	DTM	M	35	Date/time/period To specify date, and/or time, or period.		
Business Term	DE	EDIFACT	Format	St	*	Description
	C507	Date/time/period		M		
	2005	Date or time or period function code qualifier	an..3	M	*	1 Service completion date/time, actual 11 Despatch date and/or time 35 Delivery date/time, actual 36 Expiry date 50 Goods receipt date/time 137 Document/message date/time 200 Pick-up/collection date/time of cargo 263 Invoicing period 325 Tax period 454 Accounting value date 44E Connection date/time (GS1 Temporary Code)
	2380	Date or time or period value	an..35	R		
	2379	Date or time or period format code	an..3	R		102 CCYYMMDD 203 CCYYMMDDHHMM 718 CCYYMMDD-CCYYMMDD
<p>This segment is used to specify the date or period of the invoice. It may also be used to specify the date on which the goods were despatched, delivered, or received. DE 2005: Identification of the 'Document/message date/time' (code value 137) is mandatory in an EANCOM message. Example: The document date is the 8th of October 2002. The invoice relates to a delivery made on the 15th of October 2002 at 2:30pm.</p> <p>Example: DTM+137:19931008:102 ' Example: DTM+137:20021008:102 ' Example: DTM+35:200210151430:203 '</p>						

Max. Occ. = Maximum Occurrence, St = Status, * = Restricted Codes
 Status: M=Mandatory, R=Required, O=Optional, C=Conditional, D=Dependent, A=Advised, N=Not used

Segment Layout

No.	Seg	St	Max.	Occ.		
6	PAI	C	1		Payment instructions To specify the instructions for payment.	
Business Term	DE	EDIFACT	Format	St	*	Description
	C534	Payment instruction details		M		
	4439	Payment conditions code	an..3	O		1 Direct payment 65 Reverse factoring OA Open account (GS1 Temporary Code)
	4431	Payment guarantee means code	an..3	O		20 Goods as security
	4461	Payment means code	an..3	O		42 Payment to bank account 60 Promissory note 70 Bill drawn by the creditor on the debtor 10E Payment terms defined in the Commercial Account Summary (GS1 Temporary Code) 13E Payment terms defined in consolidated invoice (GS1 Temporary Code)
	1131	Code list identification code	an..17	O		
	3055	Code list responsible agency code	an..3	D		
	4435	Payment channel code	an..3	O		1 Ordinary post
<p>This segment allows the party issuing the Invoice to specify how they would like payment to be made. Example: Example: PAI+1:20:42:25:6:1 ' Example: PAI+:::42 '</p>						

Max. Occ. = Maximum Occurrence, St = Status, * = Restricted Codes
 Status: M=Mandatory, R=Required, O=Optional, C=Conditional, D=Dependent, A=Advised, N=Not used

Segment Layout

No. Seg	St	Max. Occ.			
7	ALI	C 5	Additional information		
To indicate that special conditions due to the origin, customs preference, fiscal or commercial factors are applicable.					
Business Term	DE	EDIFACT	Format	St	* Description
	3239	Country of origin name code	an..3	O	Use ISO 3166 two alpha country code.
	9213	Duty regime type code	an..3	O	
	4183	Special condition code	an..3	O	6 Subject to bonus 15 Not subject to discount 116 Subject to postponed discount 140 Return of goods 141 Subject to annual bonus 76E Special conditions applicable to only this invoice (GS1 Temporary Code) 79E Discrepancies or adjustments (GS1 Temporary Code)
	4183	Special condition code	an..3	O	
	4183	Special condition code	an..3	O	
	4183	Special condition code	an..3	O	
	4183	Special condition code	an..3	O	
This segment is used to specify any special conditions which apply to the goods being invoiced. The country of origin of all the products (if it is the same) may be specified here in the header section. Example: Example: ALI+GB+1+1+1+1+1+1 ' Example: ALI+EU '					

Max. Occ. = Maximum Occurrence, St = Status, * = Restricted Codes
 Status: M=Mandatory, R=Required, O=Optional, C=Conditional, D=Dependent, A=Advised, N=Not used

Segment Layout

No. Seg	St	Max. Occ.				
8	FTX	C 99	Free text To provide free form or coded text information.			
Business Term	DE	EDIFACT	Format	St	*	Description
	4451	Text subject code qualifier	an..3	M		BAQ VAT exemption reason PUR Purchasing information ZZZ Mutually defined
	4453	Free text function code	an..3	O	*	1 Text for subsequent use
	C107	Text reference		D		This composite is only used when trading partners have agreed to use mutually defined code values.
	4441	Free text value code	an..17	M		001 = Reference to standard text between trading partners.
	1131	Code list identification code	an..17	O		
	3055	Code list responsible agency code	an..3	D		91 Assigned by supplier or supplier's agent 92 Assigned by buyer or buyer's agent
	C108	Text literal		D		This composite is only used if coded text can not be used.
	4440	Free text value	an..51	M		
	4440	Free text value	an..51	O		
	4440	Free text value	an..51	O		
	4440	Free text value	an..51	O		
	4440	Free text value	an..51	O		
	3453	Language name code	an..3	D		ISO 639 two alpha code This data element is only used when non coded free text has been provided in data element C108.
<p>This segment is used to provide free form or coded text information which applies to the complete invoice message.</p> <p>Use of this segment in free form is not recommended since in most cases it inhibits automatic processing of the Invoice. Coded references to standard texts is an available functionality which enables automatic processing and reduces transmission and processing overheads. Standard texts should be mutually defined among trading partners and can be used to cover legal and other requirements.</p> <p>Example: (E.g. Purchasing information standard text code 001 = Please note adjusted payment terms)</p> <p>Example: FTX+ZZZ+1+001:23:6+MESSAGE HERE:FREE TEXT:FREE TEXT:FREE TEXT:FREE TEXT+EN'</p> <p>Example: FTX+PUR+1+001::91'</p>						

Max. Occ. = Maximum Occurrence, St = Status, * = Restricted Codes

Status: M=Mandatory, R=Required, O=Optional, C=Conditional, D=Dependent, A=Advised, N=Not used

Segment Layout

No. Seg	St	Max. Occ.	
SG1	C	99999	RFF-DTM
A group of segments for giving references and where necessary, their dates, relating to the whole message, e.g. contract number, import/export license number, despatch advice number.			
9	RFF	M 1	Reference
To specify a reference.			

Business Term	DE	EDIFACT	Format	St	*	Description
	C506	Reference		M		
	1153	Reference code qualifier	an..3	M		AAB Proforma invoice number AAJ Delivery order number AAK Despatch advice number AFO Beneficiary's reference ALL Message batch number AIZ Consolidated invoice number AMT Goods and Services Tax identification number APQ Commercial account summary reference number CD Credit note number CR Customer reference number DL Debit note number DQ Delivery note number IV Invoice number ON Order number (buyer) PL Price list number RF Export reference number VN Order number (supplier)
	1154	Reference identifier	an..70	R		

This segment is used to specify references which relate to the whole invoice, for example, Purchase Order Numbers, Delivery Numbers, etc.
 The message batch number (ALL) is included in this segment. This number is used to provide a link between a batch of invoice messages and a TAXCON message.
 If the document type is a credit note the invoice to which it relates may need to be specified. This is done using the 'IV' qualifier for DE 1153.
 Example:
 Example: RFF+AAB:2554125'
 Example: RFF+ALL:252'

Max. Occ. = Maximum Occurrence, St = Status, * = Restricted Codes
 Status: M=Mandatory, R=Required, O=Optional, C=Conditional, D=Dependent, A=Advised, N=Not used

INVOIC (EAN011) S3

Segment Layout

Example: RFF+ON:ORD9523'

Max. Occ. = Maximum Occurrence, St = Status, * = Restricted Codes

Status: M=Mandatory, R=Required, O=Optional, C=Conditional, D=Dependent, A=Advised, N=Not used

Segment Layout

No.	Seg	St	Max. Occ.			
	SG1	C	99999	RFF-DTM		
	A group of segments for giving references and where necessary, their dates, relating to the whole message, e.g. contract number, import/export license number, despatch advice number.					
10	DTM	C	5	Date/time/period		
	To specify date, and/or time, or period.					
Business Term	DE	EDIFACT	Format	St	*	Description
	C507	Date/time/period		M		
	2005	Date or time or period function code qualifier	an..3	M	*	171 Reference date/ time
	2380	Date or time or period value	an..35	R		
	2379	Date or time or period format code	an..3	R		102 CCYYMMDD 203 CCYYMMDDHHMM
<p>This segment is used to specify any dates related to the references given in the previous RFF segment. Example: Example: DTM+171:19930804:102 ' Example: DTM+171:20020804:102 '</p>						

Max. Occ. = Maximum Occurrence, St = Status, * = Restricted Codes
 Status: M=Mandatory, R=Required, O=Optional, C=Conditional, D=Dependent, A=Advised, N=Not used

Segment Layout

No. Seg	St	Max. Occ.				
SG2	C	99	NAD-FII-SG3-SG5			
11			A group of segments identifying the parties with associated information.			
NAD	M	1	Name and address			
			To specify the name/address and their related function, either by C082 only and/or unstructured by C058 or structured by C080 thru 3207.			
Business Term	DE	EDIFACT	Format	St	*	Description
	3035	Party function code qualifier	an..3	M		BO Broker or sales office BS Bill and ship to BY Buyer CN Consignee CS Consolidator DP Delivery party II Issuer of invoice IV Invoicee LD Party recovering the Value Added Tax (VAT) LC Party declaring the Value Added Tax (VAT) PE Payee RE Party to receive commercial invoice remittance SE Seller SN Store number SR Supplier's agent/representative ST Ship to SU Supplier
	C082	Party identification details		A		
	3039	Party identifier	an..35	M		
	1131	Code list identification code	an..17	N		
	3055	Code list responsible agency code	an..3	R	*	9 GS1
	C058	Name and address		O		This composite may only be used to fulfill the requirements of directive 2003/58/EC, article 4.
	3124	Name and address description	an..35	M		
	3124	Name and address description	an..35	O		
	3124	Name and address description	an..35	O		
	3124	Name and address description	an..35	O		
	3124	Name and address	an..35	O		

Max. Occ. = Maximum Occurrence, St = Status, * = Restricted Codes
 Status: M=Mandatory, R=Required, O=Optional, C=Conditional, D=Dependent, A=Advised, N=Not used

Segment Layout

Business Term	DE	EDIFACT	Format	St	*	Description
		description				
	C080	Party name		D		
	3036	Party name	an..35	M		Party Name in clear text.
	3036	Party name	an..35	O		
	3036	Party name	an..35	O		
	3036	Party name	an..35	O		
	3036	Party name	an..35	O		
	3045	Party name format code	an..3	O		
	C059	Street		D		
	3042	Street and number or post office box identifier	an..35	M		Building Name/Number and Street Name
	3042	Street and number or post office box identifier	an..35	O		
	3042	Street and number or post office box identifier	an..35	O		
	3042	Street and number or post office box identifier	an..35	O		
	3164	City name	an..35	D		City/Town name, clear text
	C819	Country sub-entity details		D		
	3229	Country sub-entity name code	an..9	O		
	1131	Code list identification code	an..17	O		
	3055	Code list responsible agency code	an..3	O		
	3228	Country sub-entity name	an..70	O		County/State, clear text.
	3251	Postal identification code	an..17	D		Postal Code
	3207	Country name code	an..3	D		ISO 3166 two alpha code

This segment is used to identify the trading parties involved in the invoice process. Identification of the buyer and supplier of goods and services is mandatory in the Invoice. Additionally, the issuer of the invoice and the invoicee must be identified if different from the buying and supplying parties. The consignee or delivery party needs to be specified if different to the buyer's address. Example:

Dependency Notes:

The following composites and data elements are only used when a coded name and address can not be used. The affected composites and data elements are as follows:

C080 - C059 - 3164 - C819 - 3251 - 3207

Example: NAD+BO+541234500013:::9+X:::X+P1:P2:P3:P4:P5:1+S1:S1:S1:X+DUB+IRL:23:2:X+4+IE'

Example: NAD+BY+541234500020:::9'

Example: NAD+SU+4012345500004:::9'

Example: NAD+DP+541234500013:::9'

Max. Occ. = Maximum Occurrence, St = Status, * = Restricted Codes

Status: M=Mandatory, R=Required, O=Optional, C=Conditional, D=Dependent, A=Advised, N=Not used

Segment Layout

No. Seg	St	Max. Occ.				
12	SG2	C 99	NAD-FII-SG3-SG5			
	A group of segments identifying the parties with associated information.					
	FII	C 5	Financial institution information			
To identify an account and a related financial institution.						
Business Term	DE	EDIFACT	Format	St	*	Description
	3035	Party function code qualifier	an..3	M		PB Paying financial institution RB Receiving financial institution
	C078	Account holder identification		R		
	3194	Account holder identifier	an..35	R		
	3192	Account holder name	an..35	O		
	3192	Account holder name	an..35	O		
	6345	Currency identification code	an..3	O		ISO 4217 three alpha code
	C088	Institution identification		O		
	3433	Institution name code	an..11	A		
	1131	Code list identification code	an..17	O		25 Bank identification
	3055	Code list responsible agency code	an..3	D		5 ISO (International Organization for Standardization)
	3434	Institution branch identifier	an..17	O		
	1131	Code list identification code	an..17	O		25 Bank identification
	3055	Code list responsible agency code	an..3	D		5 ISO (International Organization for Standardization)
	3432	Institution name	an..70	O		
	3436	Institution branch location name	an..70	O		
	3207	Country name code	an..3	O		ISO 3166 two alpha code
<p>This segment is used to identify financial institution information related to the party identified in the NAD segment. Example: Example: FII+PB+1:2:AAA:EUR+BK:25:5:1:25:5:1:1+AD' Example: FII+RB+994-3277711:NGEISS+KREDBEBB:25:5'</p>						

Max. Occ. = Maximum Occurrence, St = Status, * = Restricted Codes
 Status: M=Mandatory, R=Required, O=Optional, C=Conditional, D=Dependent, A=Advised, N=Not used

Segment Layout

No. Seg	St	Max. Occ.			
SG2	C	99	NAD-FII-SG3-SG5		
A group of segments identifying the parties with associated information.					
SG3	C	9999	RFF		
A group of segment for giving references only relevant to the specified party rather than the whole invoice.					
13	RFF	M	1	Reference	
To specify a reference.					
Business Term	DE	EDIFACT	Format	St	* Description
	C506	Reference		M	
	1153	Reference code qualifier	an..3	M	*
					ADE Account number
					ALV Registered capital reference
					AMT Goods and Services Tax identification number
					AP Accounts receivable number
					AQQ Activite Principale Exercee (APE) identifier
					ATB Purchase for export Customs agreement number
					EX Export licence number
					FC Fiscal number
					CR Customer reference number
					GN Government reference number
					IA Internal vendor number
					IP Import licence number
					IT Internal customer number
					PY Payee's financial institution account number
					SZ Specification number
					TRB Tribunal place registration number (GS1 Temporary Code)

Max. Occ. = Maximum Occurrence, St = Status, * = Restricted Codes
 Status: M=Mandatory, R=Required, O=Optional, C=Conditional, D=Dependent, A=Advised, N=Not used

Segment Layout

Business Term	DE	EDIFACT	Format	St	*	Description
						VA VAT registration number XA Company/place registration number YC1 Additional party identification (GS1 Temporary Code)
	1154	Reference identifier	an..70	R		

This segment is used to specify reference numbers related to the party identified in the previous NAD segment.

Example:

Example: RFF+VA:VR12345'

Example: RFF+VA:VR12345'

Max. Occ. = Maximum Occurrence, St = Status, * = Restricted Codes

Status: M=Mandatory, R=Required, O=Optional, C=Conditional, D=Dependent, A=Advised, N=Not used

Segment Layout

No. Seg	St	Max. Occ.				
SG2	C	99	NAD-FII-SG3-SG5			
A group of segments identifying the parties with associated information.						
SG5	C	5	CTA-COM			
A group of segments giving contact details of the specific person or department within the party identified in the NAD segment.						
14	CTA	M	1	Contact information		
To identify a person or a department to whom communication should be directed.						
Business Term	DE	EDIFACT	Format	St	*	Description
	3139	Contact function code	an..3	R		AD Accounting contact AP Accounts payable contact AR Accounts receivable contact GR Goods receiving contact PD Purchasing contact
	C056	Department or employee details		O		
	3413	Department or employee name code	an..17	O		
	3412	Department or employee name	an..35	O		
<p>This segment is used to identify the department and/or person within the party specified in the NAD.</p> <p>The Global Location Number GLN - Format n13 - is particularly suitable for this purpose.</p> <p>Example:</p> <p>Example: CTA+AD+A:MARK CARTER '</p> <p>Example: CTA+AD+:MARK CARTER '</p>						

Max. Occ. = Maximum Occurrence, St = Status, * = Restricted Codes
 Status: M=Mandatory, R=Required, O=Optional, C=Conditional, D=Dependent, A=Advised, N=Not used

Segment Layout

No. Seg	St	Max. Occ.				
SG2	C	99	NAD-FII-SG3-SG5			
A group of segments identifying the parties with associated information.						
SG5	C	5	CTA-COM			
A group of segments giving contact details of the specific person or department within the party identified in the NAD segment.						
15	COM	C	5	Communication contact		
To identify a communication number of a department or a person to whom communication should be directed.						
Business Term	DE	EDIFACT	Format	St	*	Description
	C076	Communication contact		M		
	3148	Communication address identifier	an..51	M		
	3155	Communication address code qualifier	an..3	M		EM Electronic mail TE Telephone AO Uniform Resource Location (URL)
This segment is used to identify the communications number and the type of communications used for the department person identified in the CTA segment. Example: Example: COM+00448132445322:TE ' Example: COM+00448132445322:TE '						

Max. Occ. = Maximum Occurrence, St = Status, * = Restricted Codes
Status: M=Mandatory, R=Required, O=Optional, C=Conditional, D=Dependent, A=Advised, N=Not used

Segment Layout

No. Seg	St	Max. Occ.				
SG6	C	5	TAX-MOA			
A group of segments specifying tax related information.						
16	TAX	M	1	Duty/tax/fee details		
To specify relevant duty/tax/fee information.						
Business Term	DE	EDIFACT	Format	St	* Description	
	5283	Duty or tax or fee function code qualifier	an..3	M	5 Customs duty 7 Tax	
	C241	Duty/tax/fee type		D		
	5153	Duty or tax or fee type name code	an..3	O	GST Goods and services tax VAT Value added tax	
	1131	Code list identification code	an..17	O		
	3055	Code list responsible agency code	an..3	D		
	5152	Duty or tax or fee type name	an..35	O		
	C533	Duty/tax/fee account detail		O		
	5289	Duty or tax or fee account code	an..6	M		
	1131	Code list identification code	an..17	O		
	3055	Code list responsible agency code	an..3	D		
	5286	Duty or tax or fee assessment basis value	an..15	O		
	C243	Duty/tax/fee detail		A		
	5279	Duty or tax or fee rate code	an..7	O		
	1131	Code list identification code	an..17	O		
	3055	Code list responsible agency code	an..3	D		
	5278	Duty or tax or fee rate	an..17	R	The actual rate of tax/duty.	
	5273	Duty or tax or fee rate basis code	an..12	O		
	1131	Code list identification code	an..17	O		
	3055	Code list responsible agency code	an..3	D		
	5305	Duty or tax or fee category code	an..3	D	A Mixed tax rate E Exempt from tax S Standard rate	
	3446	Party tax identifier	an..20	O		
This segment is used to indicate the type, category, and rate of tax for the complete invoice. Example: Dependency Notes:						

Max. Occ. = Maximum Occurrence, St = Status, * = Restricted Codes
 Status: M=Mandatory, R=Required, O=Optional, C=Conditional, D=Dependent, A=Advised, N=Not used

Segment Layout

DE C241 and 5305: Tax types and categories will vary from country to country. They should be defined by national guidelines.

Example: TAX+5+VAT:23:2:A+A:23:2+1+1:23:2:12.5:1:23:2+S+1'

Example: TAX+7+VAT+++:::21+S'

Max. Occ. = Maximum Occurrence, St = Status, * = Restricted Codes

Status: M=Mandatory, R=Required, O=Optional, C=Conditional, D=Dependent, A=Advised, N=Not used

Segment Layout

No.	Seg	St	Max.	Occ.		
	SG6	C	5		TAX-MOA	
	A group of segments specifying tax related information.					
17	MOA	C	1		Monetary amount	
	To specify a monetary amount.					
Business Term	DE	EDIFACT	Format	St	*	Description
	C516	Monetary amount		M		
	5025	Monetary amount type code qualifier	an..3	M		124 Tax amount 125 Taxable amount
	5004	Monetary amount	n..35	R		
<p>This segment is to be used to provide tax related monetary amounts relevant to the complete invoice. These amount should be added to any amounts specified in the detail section in order to calculate the total invoice tax amounts contained in the summary section.</p> <p>Example:</p> <p>Example: MOA+124:1'</p> <p>Example: MOA+124:154.54'</p>						

Max. Occ. = Maximum Occurrence, St = Status, * = Restricted Codes
 Status: M=Mandatory, R=Required, O=Optional, C=Conditional, D=Dependent, A=Advised, N=Not used

Segment Layout

No.	Seg	St	Max. Occ.	
	SG7	C	99	CUX-DTM
	A group of segments specifying the currencies and related dates/periods valid for the whole invoice.			
18	CUX	M	1	Currencies
	To specify currencies used in the transaction and relevant details for the rate of exchange.			

Business Term	DE	EDIFACT	Format	St	*	Description
	C504	Currency details		R		
	6347	Currency usage code qualifier	an..3	M	*	2 Reference currency
	6345	Currency identification code	an..3	R		ISO 4217 three alpha
	6343	Currency type code qualifier	an..3	R	*	4 Invoicing currency 10 Pricing currency 11 Payment currency
	C504	Currency details		D		The second occurrence of this composite is only used if a target currency is being specified.
	6347	Currency usage code qualifier	an..3	M	*	3 Target currency
	6345	Currency identification code	an..3	R		ISO 4217 three alpha
	6343	Currency type code qualifier	an..3	R	*	4 Invoicing currency 10 Pricing currency 11 Payment currency
	6348	Currency rate value	n..4	O		
	5402	Currency exchange rate	n..12	D		The rate of exchange which applies to the currencies. The rate of exchange is only used if a target currency has been identified in the second occurrence of C504.

This segment is used to specify currency information for the complete invoice.
 The CUX Segment is mandatory for international exchanges.
 When specifying Reference and Target Currencies for international trade, one occurrence of CUX is all that is required. The reference currency is identified in the first occurrence of composite C504, with the target currency specified in the second occurrence of C504. The rate of exchange between the two is detailed in DE 5402.
 The general rule for calculating the rate of exchange is as follows :
 Reference Currency multiplied by Rate = Target Currency.
 Example:
 Where only the invoicing currency needs to be identified for national trade.
 Example: CUX+2:EUR:4+3:EUR:4:1+49.34'
 Example: CUX+2:EUR:4'
 Example: CUX+2:EUR:4+3:USD:11+0.90243'

Max. Occ. = Maximum Occurrence, St = Status, * = Restricted Codes
 Status: M=Mandatory, R=Required, O=Optional, C=Conditional, D=Dependent, A=Advised, N=Not used

Segment Layout

No.	Seg	St	Max. Occ.			
	SG7	C	99	CUX-DTM		
	A group of segments specifying the currencies and related dates/periods valid for the whole invoice.					
19	DTM	C	5	Date/time/period		
	To specify date, and/or time, or period.					
Business Term	DE	EDIFACT	Format	St	*	Description
	C507	Date/time/period		M		
	2005	Date or time or period function code qualifier	an..3	M	*	134 Rate of exchange date/time
	2380	Date or time or period value	an..35	R		
	2379	Date or time or period format code	an..3	R		102 CCYYMMDD 718 CCYYMMDD- CCYYMMDD
<p>This segment is used to specify the date on which a rate of exchange was quoted. Example: Example: DTM+134:19931010:102' Example: DTM+134:20021010:102'</p>						

Max. Occ. = Maximum Occurrence, St = Status, * = Restricted Codes
 Status: M=Mandatory, R=Required, O=Optional, C=Conditional, D=Dependent, A=Advised, N=Not used

Segment Layout

No. Seg	St	Max. Occ.			
20	SG8	C 10	PAT-DTM-PCD-MOA-PAI-FII		
	A group of segments specifying the terms of payment applicable for the whole invoice.				
	PAT	M 1	Payment terms basis		
	To specify the payment terms basis.				
	Notes:				
	1. This segment will be removed effective with directory D.02B.				
Business Term	DE	EDIFACT	Format	St	* Description
	4279	Payment terms type code qualifier	an..3	M	1 Basic 3 Fixed date 7 Extended 20 Penalty terms 22 Discount 37 Complete payment
	C110	Payment terms		O	
	4277	Payment terms description identifier	an..17	M	ZZZ Mutually defined (GS1 Temporary Code)
	1131	Code list identification code	an..17	O	
	3055	Code list responsible agency code	an..3	D	
	4276	Payment terms description	an..35	O	
	4276	Payment terms description	an..35	O	
	C112	Terms/time information		O	
	2475	Time reference code	an..3	M	5 Date of invoice
	2009	Terms time relation code	an..3	O	3 After reference
	2151	Period type code	an..3	O	D Day M Month WD Working days Y Year
	2152	Period count quantity	n..3	O	Number of periods for payment.
<p>This segment is used by the issuer of the invoice to specify the payment terms for the complete invoice.</p> <p>Example: The following example indicates basic payment terms with payment due 30 days after the reference date which is the invoice date.</p> <p>Example: PAT+1+1:23:6:1:1+5:3:D:30' Example: PAT+1++5:3:D:30'</p>					

Max. Occ. = Maximum Occurrence, St = Status, * = Restricted Codes
 Status: M=Mandatory, R=Required, O=Optional, C=Conditional, D=Dependent, A=Advised, N=Not used

Segment Layout

No.	Seg	St	Max. Occ.			
	SG8	C	10	PAT-DTM-PCD-MOA-PAI-FII		
	A group of segments specifying the terms of payment applicable for the whole invoice.					
21	DTM	C	5	Date/time/period		
	To specify date, and/or time, or period.					
Business Term	DE	EDIFACT	Format	St	*	Description
	C507	Date/time/period		M		
	2005	Date or time or period function code qualifier	an..3	M	*	7 Effective date/time 12 Terms discount due date/time 13 Terms net due date 209 Value date 326 Charge period
	2380	Date or time or period value	an..35	R		
	2379	Date or time or period format code	an..3	R		102 CCYYMMDD 718 CCYYMMDD-CCYYMMDD
<p>This segment is used to specify any dates associated with the payment terms for the invoice. Example: Net due date for payment the 31st August 2002.</p> <p>Example: DTM+7:19930831:102' Example: DTM+13:20020831:102'</p>						

Max. Occ. = Maximum Occurrence, St = Status, * = Restricted Codes
 Status: M=Mandatory, R=Required, O=Optional, C=Conditional, D=Dependent, A=Advised, N=Not used

Segment Layout

No. Seg	St	Max. Occ.				
22	SG8	C 10	PAT-DTM-PCD-MOA-PAI-FII			
	A group of segments specifying the terms of payment applicable for the whole invoice.					
	PCD	C 1	Percentage details			
To specify percentage information.						
Business Term	DE	EDIFACT	Format	St	*	Description
	C501	Percentage details		M		
	5245	Percentage type code qualifier	an..3	M		7 Percentage of invoice 12 Discount 15 Penalty percentage 16 Interest percentage
	5482	Percentage	n..10	R		
	5249	Percentage basis identification code	an..3	O		13 Invoice value
	1131	Code list identification code	an..17	O		
	3055	Code list responsible agency code	an..3	D		
<p>This segment is used to specify percentages which will be allowed or charged if the invoicee pays (does not pay) to terms. Example: Example: PCD+1:95.5:13:23:6 ' Example: PCD+15:2.5:13'</p>						

Max. Occ. = Maximum Occurrence, St = Status, * = Restricted Codes
 Status: M=Mandatory, R=Required, O=Optional, C=Conditional, D=Dependent, A=Advised, N=Not used

Segment Layout

No.	Seg	St	Max.	Occ.	
	SG8	C	10		PAT-DTM-PCD-MOA-PAI-FII
	A group of segments specifying the terms of payment applicable for the whole invoice.				
23	MOA	C	1		Monetary amount
	To specify a monetary amount.				
Business Term	DE	EDIFACT	Format	St	* Description
	C516	Monetary amount		M	
	5025	Monetary amount type code qualifier	an..3	M	21 Cash discount 23 Charge amount 529 Calculation basis which includes all taxes except VAT
	5004	Monetary amount	n..35	R	Actual value being charged/discounted.
<p>This segment is used to specify monetary values which will be allowed or charged if the invoicee pays (does not pay) to terms. Example: Example: MOA+21:100' Example: MOA+21:100'</p>					

Max. Occ. = Maximum Occurrence, St = Status, * = Restricted Codes
 Status: M=Mandatory, R=Required, O=Optional, C=Conditional, D=Dependent, A=Advised, N=Not used

Segment Layout

No.	Seg	St	Max.	Occ.	
	SG8	C	10		PAT-DTM-PCD-MOA-PAI-FII A group of segments specifying the terms of payment applicable for the whole invoice.
24	PAI	C	1		Payment instructions To specify the instructions for payment.
Business Term	DE	EDIFACT	Format	St	* Description
	C534	Payment instruction details		M	
	4439	Payment conditions code	an..3	O	10 Irrevocable documentary credit
	4431	Payment guarantee means code	an..3	O	
	4461	Payment means code	an..3	O	42 Payment to bank account
	1131	Code list identification code	an..17	O	
	3055	Code list responsible agency code	an..3	D	
	4435	Payment channel code	an..3	O	
<p>This segment is used to specify payment instructions related to payment terms. Example: The following example indicates that payment has to be made to a bank account. Example: PAI+1:10:42:23:2:1 ' Example: PAI+::42 '</p>					

Max. Occ. = Maximum Occurrence, St = Status, * = Restricted Codes
 Status: M=Mandatory, R=Required, O=Optional, C=Conditional, D=Dependent, A=Advised, N=Not used

Segment Layout

No. Seg	St	Max. Occ.				
25	SG8	C 10	PAT-DTM-PCD-MOA-PAI-FII			
	A group of segments specifying the terms of payment applicable for the whole invoice.					
	FII	C 1	Financial institution information			
To identify an account and a related financial institution.						
Business Term	DE	EDIFACT	Format	St	*	Description
	3035	Party function code qualifier	an..3	M	*	RB Receiving financial institution
	C078	Account holder identification		R		
	3194	Account holder identifier	an..35	R		
	3192	Account holder name	an..35	O		
	3192	Account holder name	an..35	O		
	6345	Currency identification code	an..3	O		ISO 4217 three alpha code
	C088	Institution identification		O		
	3433	Institution name code	an..11	R		
	1131	Code list identification code	an..17	O		25 Bank identification
	3055	Code list responsible agency code	an..3	D		5 ISO (International Organization for Standardization)
	3434	Institution branch identifier	an..17	O		
	1131	Code list identification code	an..17	O		25 Bank identification
	3055	Code list responsible agency code	an..3	D		5 ISO (International Organization for Standardization)
	3432	Institution name	an..70	O		
	3436	Institution branch location name	an..70	O		
	3207	Country name code	an..3	O		ISO 3166 two alpha code
<p>This segment is used to identify the receiving financial institution and account holder number, related to the payment means. Example: Example: FII+RB+1:2:AAA:EUR+BK:25:5:1:25:5:1:1+AD' Example: FII+RB+994-3277711+KREDBEBB:25:5'</p>						

Max. Occ. = Maximum Occurrence, St = Status, * = Restricted Codes
 Status: M=Mandatory, R=Required, O=Optional, C=Conditional, D=Dependent, A=Advised, N=Not used

Segment Layout

No. Seg	St	Max. Occ.			
SG9	C	10	TDT-SG10-SG11		
			A group of segments identifying the mode and means of transport, location and relevant dates and times for transportation, relating to the whole invoice.		
26	TDT	M 1	Details of transport		
			To specify the transport details such as mode of transport, means of transport, its conveyance reference number and the identification of the means of transport.		
Business Term	DE	EDIFACT	Format	St	* Description
	8051	Transport stage code qualifier	an..3	M	20 Main-carriage transport
	8028	Means of transport journey identifier	an..17	O	Reference number covering the transport.
	C220	Mode of transport		A	
	8067	Transport mode name code	an..3	R	
	C228	Transport means		O	
	8179	Transport means description code	an..8	D	23 Rail bulk car 31 Truck
	8178	Transport means description	an..17	D	
	C040	Carrier		O	
	3127	Carrier identifier	an..17	A	
	1131	Code list identification code	an..17	O	
	3055	Code list responsible agency code	an..3	D *	9 GS1 60 Assigned by national trade agency DE 3055 must be used if DE 3127 is used.
	3128	Carrier name	an..35	O	
	8101	Transit direction indicator code	an..3	O	BS Buyer to supplier SB Supplier to buyer
	C401	Excess transportation information		N	
	8457	Excess transportation reason code	an..3		
	C222	Transport identification		O	
	8213	Transport means identification name identifier	an..9	O	
	1131	Code list identification code	an..17	O	
	3055	Code list responsible agency code	an..3	D	DE 3055 must be used if DE 8213 is used.
	8212	Transport means identification name	an..35	R	Vehicle licence plate/Aircraft number

Max. Occ. = Maximum Occurrence, St = Status, * = Restricted Codes

Status: M=Mandatory, R=Required, O=Optional, C=Conditional, D=Dependent, A=Advised, N=Not used

Segment Layout

Business Term	DE	EDIFACT	Format	St	*	Description
	8453	Transport means nationality code	an..3	O		ISO 3166 two alpha code
<p>This segment is used to specify transport services provided for the delivery of the invoiced line items, such as express transport services.</p> <p>Example:</p> <p>Dependency Notes:</p> <p>DE C228: DE 8179 and 8178 are only used when the type of transport must be specifically identified, i.e. where a generic description such as road transport is unsuitable.</p> <p>Example: TDT+13+10032+3+31:A+ABC123:23:9:EX+SB++524SQ744:23:6:A:GB'</p> <p>Example: TDT+20++30+31'</p>						

Max. Occ. = Maximum Occurrence, St = Status, * = Restricted Codes

Status: M=Mandatory, R=Required, O=Optional, C=Conditional, D=Dependent, A=Advised, N=Not used

Segment Layout

No. Seg	St	Max. Occ.				
SG9	C	10	TDT-SG10-SG11			
A group of segments identifying the mode and means of transport, location and relevant dates and times for transportation, relating to the whole invoice.						
SG10	C	10	LOC-DTM			
A group of segments giving the location and date/time information relative to the transportation.						
27	LOC	M	1	Place/location identification		
To identify a place or a location and/or related locations.						
Business Term	DE	EDIFACT	Format	St	*	Description
	3227	Location function code qualifier	an..3	M		8 Place of destination 9 Place/port of loading
	C517	Location identification		A		
	3225	Location name code	an..25	A		GLN - Format n13
	1131	Code list identification code	an..17	O		
	3055	Code list responsible agency code	an..3	D		9 GS1 DE 3055 must be used if DE 3225 is used and does not contain an UN/LOCODE.
	3224	Location name	an..25	O		
	C519	Related location one identification		O		
	3223	First related location name code	an..25	O		Global Location Number GLN - Format n13
	1131	Code list identification code	an..17	O		
	3055	Code list responsible agency code	an..3	D		DE 3055 must be used if DE 3223 is used and does not contain an UN/LOCODE. 9 GS1
	3222	First related location name	an..70	O		
	C553	Related location two identification		O		
	3233	Second related location name code	an..25	O		Global Location Number GLN - Format n13
	1131	Code list identification code	an..17	O		
	3055	Code list responsible agency code	an..3	D		DE 3055 must be used if DE 3233 is used and does not contain an UN/LOCODE. 9 GS1
	3232	Second related location name	an..70	O		
This segment is used to identify locations related to the details of transport.						

Max. Occ. = Maximum Occurrence, St = Status, * = Restricted Codes
 Status: M=Mandatory, R=Required, O=Optional, C=Conditional, D=Dependent, A=Advised, N=Not used

Segment Layout

Example:

Example: LOC+1+X:23:9:X+:23:9:X+:23:9:X'

Example: LOC+5+5412345678908::9'

Max. Occ. = Maximum Occurrence, St = Status, * = Restricted Codes

Status: M=Mandatory, R=Required, O=Optional, C=Conditional, D=Dependent, A=Advised, N=Not used

Segment Layout

No. Seg	St	Max. Occ.				
SG9	C	10	TDT-SG10-SG11			
A group of segments identifying the mode and means of transport, location and relevant dates and times for transportation, relating to the whole invoice.						
SG10	C	10	LOC-DTM			
A group of segments giving the location and date/time information relative to the transportation.						
28	DTM	C	5	Date/time/period		
To specify date, and/or time, or period.						
Business Term	DE	EDIFACT	Format	St	*	Description
	C507	Date/time/period		M		
	2005	Date or time or period function code qualifier	an..3	M		35 Delivery date/time, actual 132 Arrival date/time, estimated 133 Departure date/time, estimated 186 Departure date/time, actual
	2380	Date or time or period value	an..35	R		
	2379	Date or time or period format code	an..3	R		
This segment is used to specify dates related to the above location. Example: Example: DTM+2:X:2' Example: DTM+132:20010606:102'						

Max. Occ. = Maximum Occurrence, St = Status, * = Restricted Codes
Status: M=Mandatory, R=Required, O=Optional, C=Conditional, D=Dependent, A=Advised, N=Not used

Segment Layout

No. Seg	St	Max. Occ.				
SG9	C	10	TDT-SG10-SG11			
A group of segments identifying the mode and means of transport, location and relevant dates and times for transportation, relating to the whole invoice.						
SG11	C	9999	RFF			
29	RFF	M	1	Reference		
To specify a reference.						
Business Term	DE	EDIFACT	Format	St	*	Description
	C506	Reference		M		
	1153	Reference code qualifier	an..3	M		AAB Proforma invoice number AAJ Delivery order number AAK Despatch advice number AFO Beneficiary's reference ALL Message batch number AIZ Consolidated invoice number AMT Goods and Services Tax identification number APQ Commercial account summary reference number CD Credit note number CR Customer reference number DL Debit note number DQ Delivery note number IV Invoice number ON Order number (buyer) PL Price list number RF Export reference number VN Order number (supplier)
	1154	Reference identifier	an..70	R		
Example: RFF+AAB:2554125'						

Max. Occ. = Maximum Occurrence, St = Status, * = Restricted Codes
 Status: M=Mandatory, R=Required, O=Optional, C=Conditional, D=Dependent, A=Advised, N=Not used

Segment Layout

No. Seg	St	Max. Occ.				
SG12	C	5	TOD-LOC			
A group of segments indicating the terms of delivery for the whole invoice.						
30	TOD	M	1	Terms of delivery or transport		
To specify terms of delivery or transport.						
Business Term	DE	EDIFACT	Format	St	*	Description
	4055	Delivery or transport terms function code	an..3	R		3 Price and despatch condition 6 Delivery condition
	4215	Transport charges payment method code	an..3	O		DF Defined by buyer and supplier PC Prepaid but charged to customer
	C100	Terms of delivery or transport		A		
	4053	Delivery or transport terms description code	an..3	R		INCOTERMS (See EANCOM Codes Set) If INCOTERMS are applicable, then DE 3055 has to contain code value "9" and DE 1131 must be used.
	1131	Code list identification code	an..17	D		
	3055	Code list responsible agency code	an..3	D		
	4052	Delivery or transport terms description	an..70	O		
	4052	Delivery or transport terms description	an..70	O		
<p>This segment is used to specify the terms of delivery for the complete invoice. Example: Dependency Notes: Data elements 1131 and 3055 are only used if specific terms of delivery codes, which are outside those recommended by EDIFACT, are being used.</p> <p>Example: <code>TOD+6+PP+01E:23:6:12:1'</code> Example: <code>TOD+3++CIF:2E:9'</code></p>						

Max. Occ. = Maximum Occurrence, St = Status, * = Restricted Codes
 Status: M=Mandatory, R=Required, O=Optional, C=Conditional, D=Dependent, A=Advised, N=Not used

Segment Layout

No. Seg	St	Max. Occ.				
31	SG12	C 5	TOD-LOC A group of segments indicating the terms of delivery for the whole invoice.			
	LOC	C 2	Place/location identification To identify a place or a location and/or related locations.			
Business Term	DE	EDIFACT	Format	St	*	Description
	3227	Location function code qualifier	an..3	M		1 Place of terms of delivery 5 Place of departure 7 Place of delivery
	C517	Location identification		A		
	3225	Location name code	an..25	A		UN/LOCODE
	1131	Code list identification code	an..17	O		
	3055	Code list responsible agency code	an..3	D		3 IATA (International Air Transport Association) DE 3055 must be used if DE 3225 is used and does not contain an UN/LOCODE.
	3224	Location name	an..25	O		
<p>This segment is used to identify the location where the terms of delivery apply. Example: Example: LOC+1+1:23:3:1' Example: LOC+1+BE-BRU'</p>						

Max. Occ. = Maximum Occurrence, St = Status, * = Restricted Codes
 Status: M=Mandatory, R=Required, O=Optional, C=Conditional, D=Dependent, A=Advised, N=Not used

Segment Layout

No. Seg	St	Max. Occ.				
SG14	C	1000	PAC			
			A group of segments identifying the packaging for goods referenced by the whole invoice.			
32	PAC	M 1	Package			
			To describe the number and type of packages/physical units.			
Business Term	DE	EDIFACT	Format	St	*	Description
	7224	Package quantity	n..8	O		
	C531	Packaging details		O		
	7075	Packaging level code	an..3	O		
	7233	Packaging related description code	an..3	O		
	7073	Packaging terms and conditions code	an..3	O		1 Packaging cost paid by supplier 2 Packaging cost paid by recipient 3 Packaging cost not charged (returnable)
	C202	Package type		R		
	7065	Package type description code	an..17	A		
	1131	Code list identification code	an..17	O		
	3055	Code list responsible agency code	an..3	D		
	7064	Type of packages	an..35	O		
	C402	Package type identification		N		
	7077	Description format code	an..3			
	C532	Returnable package details		D		Composite C532 is only used where the packaging being described is returnable. This composite identifies who is responsible for payment of its return.
	8395	Returnable package freight payment responsibility code	an..3	O		1 Paid by customer 3 Paid by supplier
<p>This segment is used to enable the invoice message to be used as valued despatch advice message by detailing the total count of each package type being invoiced.</p> <p>Example: The invoice relates to 6 crates.</p> <p>Example: PAC+1+1:1:1+AE:23:2:1+1'</p> <p>Example: PAC+6++CR'</p>						

Max. Occ. = Maximum Occurrence, St = Status, * = Restricted Codes
 Status: M=Mandatory, R=Required, O=Optional, C=Conditional, D=Dependent, A=Advised, N=Not used

Segment Layout

No. Seg	St	Max. Occ.				
SG16	C	9999	ALC-SG18-SG19-SG20-SG21-SG22			
A group of segments specifying allowances and charges for the whole invoice. Allowances and charges in the heading section of a message are independent from those in the detail section, e.g. ALC at detail level does not override ALC at heading level.						
33	ALC	M 1	Allowance or charge			
To identify allowance or charge details.						
Business Term	DE	EDIFACT	Format	St	*	Description
	5463	Allowance or charge code qualifier	an..3	M		A Allowance C Charge
	C552	Allowance/charge information		O		
	1230	Allowance or charge identifier	an..35	D		If code '69' is used in DE 5189, the agreement number must be specified in DE 1230.
	5189	Allowance or charge identification code	an..3	O		69 Charge for a customer specific finish 105 Yearly turnover
	4471	Settlement means code	an..3	O		1 Bill back 2 Off invoice 5 Charge to be paid by vendor 6 Charge to be paid by customer
	1227	Calculation sequence code	an..3	D		1 First step of calculation 2 Second step of calculation etc, etc, etc, 9 Ninth step of calculation If the allowance or charge is not to be applied against a fixed price then the calculation sequence indicator must be included.
	C214	Special services identification		D		
	7161	Special service description code	an..3	R		AJ Adjustments CAC Cash discount AEK Cash on delivery service EAB Early payment allowance FC Freight charge FI Finance charge HD Handling QD Quantity discount X40 Allowance/charge regulated by law

Max. Occ. = Maximum Occurrence, St = Status, * = Restricted Codes
 Status: M=Mandatory, R=Required, O=Optional, C=Conditional, D=Dependent, A=Advised, N=Not used

Segment Layout

Business Term	DE	EDIFACT	Format	St	*	Description
						(GS1 Temporary Code)
	1131	Code list identification code	an..17	O		
	3055	Code list responsible agency code	an..3	D		
	7160	Special service description	an..35	O		
	7160	Special service description	an..35	O		

This segment is used to indicate any Allowances or Charges applicable to the total invoice, e.g. packaging costs.

Allowances or charges specified in the detail section do not override or replace allowances or charges specified at header level but compliment them.

Example:

Freight charges to be paid by the customer.

Example: ALC+A+ALL1234:69+6+1+AJ:132:6:1:1'

Example: ALC+C++6++FC'

Max. Occ. = Maximum Occurrence, St = Status, * = Restricted Codes

Status: M=Mandatory, R=Required, O=Optional, C=Conditional, D=Dependent, A=Advised, N=Not used

Segment Layout

No. Seg	St	Max. Occ.				
SG16	C	9999	ALC-SG18-SG19-SG20-SG21-SG22			
A group of segments specifying allowances and charges for the whole invoice. Allowances and charges in the heading section of a message are independent from those in the detail section, e.g. ALC at detail level does not override ALC at heading level.						
SG18	C	1	QTY			
A group of segments specifying the quantity of the allowance or charge with its measure unit specifier.						
34	QTY	M	1	Quantity		
To specify a pertinent quantity.						
Business Term	DE	EDIFACT	Format	St	*	Description
	C186	Quantity details		M		
	6063	Quantity type code qualifier	an..3	M		1 Discrete quantity
	6060	Quantity	an..35	M		Actual quantity being allowed or charged.
	6411	Measurement unit code	an..3	D		DE 6411 is only used if a variable quantity product or service is being indicated in the allowance or charge.
This segment is used to specify any quantity discounts or charges for the current ALC segment group. Example: Example: QTY+1:152:KGM' Example: QTY+1:152'						

Max. Occ. = Maximum Occurrence, St = Status, * = Restricted Codes
 Status: M=Mandatory, R=Required, O=Optional, C=Conditional, D=Dependent, A=Advised, N=Not used

Segment Layout

No. Seg	St	Max. Occ.				
SG16	C	9999	ALC-SG18-SG19-SG20-SG21-SG22			
A group of segments specifying allowances and charges for the whole invoice. Allowances and charges in the heading section of a message are independent from those in the detail section, e.g. ALC at detail level does not override ALC at heading level.						
SG19	C	1	PCD			
A group of segments specifying the percentage for the allowance or charge.						
35	PCD	M	1	Percentage details		
To specify percentage information.						
Business Term	DE	EDIFACT	Format	St	*	Description
	C501	Percentage details		M		
	5245	Percentage type code qualifier	an..3	M		1 Allowance 2 Charge
	5482	Percentage	n..10	R		
	5249	Percentage basis identification code	an..3	O		1 Per unit 13 Invoice value
	1131	Code list identification code	an..17	O		
	3055	Code list responsible agency code	an..3	D		
This segment is used to specify any percentage discounts or charges for the current ALC segment group. Example: Example: PCD+1:1.45:13:23:2' Example: PCD+1:1.45:13'						

Max. Occ. = Maximum Occurrence, St = Status, * = Restricted Codes
Status: M=Mandatory, R=Required, O=Optional, C=Conditional, D=Dependent, A=Advised, N=Not used

Segment Layout

No. Seg	St	Max. Occ.				
SG16	C	9999	ALC-SG18-SG19-SG20-SG21-SG22			
A group of segments specifying allowances and charges for the whole invoice. Allowances and charges in the heading section of a message are independent from those in the detail section, e.g. ALC at detail level does not override ALC at heading level.						
SG20	C	2	MOA			
A group of segments specifying a monetary amount for an allowance or charge.						
36	MOA	M	1	Monetary amount		
To specify a monetary amount.						
Business Term	DE	EDIFACT	Format	St	*	Description
	C516	Monetary amount		M		
	5025	Monetary amount type code qualifier	an..3	M		8 Allowance or charge amount 23 Charge amount 236 Amount subject to price adjustment 286 Administration charge 529 Calculation basis which includes all taxes except VAT
	5004	Monetary amount	n..35	R		
This segment is used to specify any monetary discounts or charges for the current ALC segment group. Example: Example: MOA+8:125.00' Example: MOA+8:125.00'						

Max. Occ. = Maximum Occurrence, St = Status, * = Restricted Codes
 Status: M=Mandatory, R=Required, O=Optional, C=Conditional, D=Dependent, A=Advised, N=Not used

Segment Layout

No. Seg	St	Max. Occ.				
SG16	C	9999	ALC-SG18-SG19-SG20-SG21-SG22			
A group of segments specifying allowances and charges for the whole invoice. Allowances and charges in the heading section of a message are independent from those in the detail section, e.g. ALC at detail level does not override ALC at heading level.						
SG21	C	1	RTE			
A group of segments specifying the rate per unit and basis to which the allowance or charge applies, e.g. the allowance/charge amount is 3 EUR per 10 tons.						
37	RTE	M	1	Rate details		
To specify rate information.						
Business Term	DE	EDIFACT	Format	St	*	Description
	C128	Rate details		M		
	5419	Rate type code qualifier	an..3	M		1 Allowance rate 2 Charge rate
	5420	Unit price basis rate	n..15	M		Used to identify the monetary value.
	5284	Unit price basis value	n..9	O		The quantity required for the rate to be effective.
	6411	Measurement unit code	an..3	D		DE 6411 is only used if a variable quantity product or service is being indicated in the allowance or charge.
<p>This segment is used to specify rate discounts or charges for the current ALC segment group. Example: Allowance rate of 500 EUR per 100 units (the value is expressed in the currency of the message). Example: RTE+1:500:100:KGM' Example: RTE+1:500:100'</p>						

Max. Occ. = Maximum Occurrence, St = Status, * = Restricted Codes
 Status: M=Mandatory, R=Required, O=Optional, C=Conditional, D=Dependent, A=Advised, N=Not used

Segment Layout

No. Seg	St	Max. Occ.				
SG16	C	9999	ALC-SG18-SG19-SG20-SG21-SG22			
A group of segments specifying allowances and charges for the whole invoice. Allowances and charges in the heading section of a message are independent from those in the detail section, e.g. ALC at detail level does not override ALC at heading level.						
SG22	C	5	TAX-MOA			
A group of segments specifying tax related information for the allowance or charge.						
38	TAX	M	1	Duty/tax/fee details		
To specify relevant duty/tax/fee information.						
Business Term	DE	EDIFACT	Format	St	*	Description
	5283	Duty or tax or fee function code qualifier	an..3	M		5 Customs duty 7 Tax
	C241	Duty/tax/fee type		D		
	5153	Duty or tax or fee type name code	an..3	O		GST Goods and services tax VAT Value added tax
	1131	Code list identification code	an..17	O		
	3055	Code list responsible agency code	an..3	D		
	5152	Duty or tax or fee type name	an..35	O		
	C533	Duty/tax/fee account detail		O		
	5289	Duty or tax or fee account code	an..6	M		
	1131	Code list identification code	an..17	O		
	3055	Code list responsible agency code	an..3	D		
	5286	Duty or tax or fee assessment basis value	an..15	O		
	C243	Duty/tax/fee detail		A		
	5279	Duty or tax or fee rate code	an..7	O		
	1131	Code list identification code	an..17	O		
	3055	Code list responsible agency code	an..3	D		
	5278	Duty or tax or fee rate	an..17	R		The actual rate of tax/duty.
	5273	Duty or tax or fee rate basis code	an..12	O		
	1131	Code list identification code	an..17	O		
	3055	Code list responsible agency code	an..3	D		
	5305	Duty or tax or fee category code	an..3	D		A Mixed tax rate E Exempt from tax S Standard rate

Max. Occ. = Maximum Occurrence, St = Status, * = Restricted Codes
 Status: M=Mandatory, R=Required, O=Optional, C=Conditional, D=Dependent, A=Advised, N=Not used

Segment Layout

Business Term	DE	EDIFACT	Format	St	*	Description
	3446	Party tax identifier	an..20	O		
<p>This segment is used to signify whether the allowances and charges specified in SG16 are subject to tax. Example: Dependency Notes: DE C241 and 5305: Tax types and categories will vary from country to country. They should be defined by national guidelines.</p> <p>Example: TAX+7+VAT:23:6:1+1:23:6+1+1:23:6:21:1:23:6+S+12 ' Example: TAX+7+VAT++++::21+S'</p>						

Max. Occ. = Maximum Occurrence, St = Status, * = Restricted Codes
 Status: M=Mandatory, R=Required, O=Optional, C=Conditional, D=Dependent, A=Advised, N=Not used

Segment Layout

No.	Seg	St	Max. Occ.			
	SG16	C	9999	ALC-SG18-SG19-SG20-SG21-SG22		
	A group of segments specifying allowances and charges for the whole invoice. Allowances and charges in the heading section of a message are independent from those in the detail section, e.g. ALC at detail level does not override ALC at heading level.					
	SG22	C	5	TAX-MOA		
	A group of segments specifying tax related information for the allowance or charge.					
39	MOA	C	1	Monetary amount		
	To specify a monetary amount.					
Business Term	DE	EDIFACT	Format	St	*	Description
	C516	Monetary amount		M		
	5025	Monetary amount type code qualifier	an..3	M		124 Tax amount 125 Taxable amount
	5004	Monetary amount	n..35	R		
This segment is used to indicate tax or duty amount for the tax rates specified in the previous TAX segment. Example: Example: MOA+1:1.23' Example: MOA+124:154.76'						

Max. Occ. = Maximum Occurrence, St = Status, * = Restricted Codes
Status: M=Mandatory, R=Required, O=Optional, C=Conditional, D=Dependent, A=Advised, N=Not used

Segment Layout

No.	Seg	St	Max.	Occ.		
	SG24	C	1		AJT	
40	AJT	M	1		Adjustment details To identify the reason for an adjustment.	
Business Term	DE	EDIFACT	Format	St	*	Description
	4465	Adjustment reason description code	an..3	M		3 Damaged goods 5 Price query 9 Invoice error If adjustments are made due to national tax practices then code values to identify these national practices may be allocated for use with this data element by national GS1 Member Organisations.
This segment is used to indicate the reason for an adjustment to the current document. Adjustments can be given only if the invoice type is a credit note or debit note (BGM, DE1001 = 83, 84, 381 or 383). Example: Example: AJT+3 ' Example: AJT+3 '						

Max. Occ. = Maximum Occurrence, St = Status, * = Restricted Codes
 Status: M=Mandatory, R=Required, O=Optional, C=Conditional, D=Dependent, A=Advised, N=Not used

Segment Layout

No. Seg	St	Max. Occ.			
SG26	C	9999999	LIN-PIA-IMD-MEA-QTY-ALI-DTM-GIN-QVR-FTX-SG27-SG28-SG29-SG30-SG31-SG33-SG34-SG35-SG39-SG45-SG47		
A group of segments providing details of the individual invoiced items. There must be at least one occurrence of Segment group 26 within an invoice, but not necessarily in a credit note or a debit note. This Segment group may be repeated to give sub-line details.					
41	LIN	M 1	Line item		
To identify a line item and configuration.					
Business Term	DE	EDIFACT	Format	St	* Description
	1082	Line item identifier	an..6	R	Application generated number of the item lines within the invoice.
	1229	Action request/ notification description code	an..3	N	
	C212	Item number identification		D	This composite is only used for the identification of GS1 codes. If another coding structure is required, e.g., HIBC, this composite will not be used and the code will be detailed in the PIA segment.
	7140	Item identifier	an..35	R	Format n..14. GTIN - this is the number of the article being invoiced.
	7143	Item type identification code	an..3	R	* SRV GS1 Global Trade Item Number
	C829	Sub-line information		D	
	5495	Sub-line indicator code	an..3	R	* 1 Sub-line information
	1082	Line item identifier	an..6	R	
<p>This segment is used to identify the item being invoiced.</p> <p>Note on DE 1082: Numbering rule: In Part I, section 4.10 there is the recommendation "Within EANCOM® it is recommended that the line numbers used in the first occurrence of data element 1082 in the LIN segment be sequential, starting at 1 for each new message."</p> <p>Note on DE 7140: Only the following significant digits are possible: - 8 digits for GTIN 8 codes - 12 digits for GTIN 12 codes - 13 digits for GTIN 13 codes - 14 digits for GTIN 14 codes</p> <p>Dependency Note: C829 is only used when sub-lines are required.</p> <p>FOR A COMPLETE DESCRIPTION ON THE USAGE OF SUB-LINES PLEASE REFER TO PART I, SECTION 4.10.</p> <p>Example: LIN+1++4000862141404:SRV+1:1'</p>					

Max. Occ. = Maximum Occurrence, St = Status, * = Restricted Codes
 Status: M=Mandatory, R=Required, O=Optional, C=Conditional, D=Dependent, A=Advised, N=Not used

INVOIC (EAN011) S3

Segment Layout

Example: LIN+1++4000862141404:SRV'

Max. Occ. = Maximum Occurrence, St = Status, * = Restricted Codes
Status: M=Mandatory, R=Required, O=Optional, C=Conditional, D=Dependent, A=Advised, N=Not used

Segment Layout

No. Seg	St	Max. Occ.			
SG26	C	9999999	LIN-PIA-IMD-MEA-QTY-ALI-DTM-GIN-QVR-FTX-SG27-SG28-SG29-SG30-SG31-SG33-SG34-SG35-SG39-SG45-SG47		
A group of segments providing details of the individual invoiced items. There must be at least one occurrence of Segment group 26 within an invoice, but not necessarily in a credit note or a debit note. This Segment group may be repeated to give sub-line details.					
42	PIA	C 25	Additional product id		
To specify additional or substitutional item identification codes.					
Business Term	DE	EDIFACT	Format	St	* Description
	4347	Product identifier code qualifier	an..3	M	* 1 Additional identification 4 Substituted for 5 Product identification
	C212	Item number identification		M	
	7140	Item identifier	an..35	R	
	7143	Item type identification code	an..3	R	PV Promotional variant number HS Harmonised system IN Buyer's item number SA Supplier's article number SRV GS1 Global Trade Item Number EWC European Waste Catalogue (GS1 Temporary Code)
	1131	Code list identification code	an..17	O	
	3055	Code list responsible agency code	an..3	D	9 GS1 91 Assigned by supplier or supplier's agent 92 Assigned by buyer or buyer's agent
	C212	Item number identification		O	
	7140	Item identifier	an..35	R	
	7143	Item type identification code	an..3	R	
	1131	Code list identification code	an..17	O	
	3055	Code list responsible agency code	an..3	D	
	C212	Item number identification		O	
	7140	Item identifier	an..35	R	
	7143	Item type identification code	an..3	R	

Max. Occ. = Maximum Occurrence, St = Status, * = Restricted Codes
 Status: M=Mandatory, R=Required, O=Optional, C=Conditional, D=Dependent, A=Advised, N=Not used

Segment Layout

Business Term	DE	EDIFACT	Format	St	*	Description
	1131	Code list identification code	an..17	O		
	3055	Code list responsible agency code	an..3	D		
	C212	Item number identification		O		
	7140	Item identifier	an..35	R		
	7143	Item type identification code	an..3	R		
	1131	Code list identification code	an..17	O		
	3055	Code list responsible agency code	an..3	D		
	C212	Item number identification		O		
	7140	Item identifier	an..35	R		
	7143	Item type identification code	an..3	R		
	1131	Code list identification code	an..17	O		
	3055	Code list responsible agency code	an..3	D		

This segment is used to specify additional or substitutional item identification codes such as a buyer's or supplier's item number.

Examples:

In this example the PIA segment is used to provide an additional identification to the GTIN provided in the LIN segment. The GTIN 4000862141404 provided in the LIN segment refers to the internal buyer's item number ABC5343.

In this example the PIA segment is used to provide the number of the product which has been substituted by the invoiced product identified in the LIN segment by the GTIN 4000862141404. This example details the HIBC code 2209953C001L which is provided as the primary product code because no GTIN was provided in the LIN segment.

Example: PIA+5+ABC5343:SA:23:92+1:IN:23:6+2:IN:23:6+3:IN:23:6+4:IN:23:6'

Example: PIA+1+ABC5343:IN'

Example: PIA+4+5412345111184:SRV'

Example: PIA+5+2209953C001L:AC'

Max. Occ. = Maximum Occurrence, St = Status, * = Restricted Codes

Status: M=Mandatory, R=Required, O=Optional, C=Conditional, D=Dependent, A=Advised, N=Not used

Segment Layout

No. Seg	St	Max. Occ.				
SG26	C	9999999	LIN-PIA-IMD-MEA-QTY-ALI-DTM-GIN-QVR-FTX-SG27-SG28-SG29-SG30-SG31-SG33-SG34-SG35-SG39-SG45-SG47			
			A group of segments providing details of the individual invoiced items. There must be at least one occurrence of Segment group 26 within an invoice, but not necessarily in a credit note or a debit note. This Segment group may be repeated to give sub-line details.			
43						
IMD	C	99	Item description			
			To describe an item in either an industry or free format.			
Business Term	DE	EDIFACT	Format	St	*	Description
	7077	Description format code	an..3	O	*	A Free-form long description B Code and text C Code (from industry code list) E Free-form short description F Free-form S Structured (from industry code list)
	C272	Item characteristic		O		
	7081	Item characteristic code	an..3	R		
	1131	Code list identification code	an..17	O		
	3055	Code list responsible agency code	an..3	D	*	9 GS1 Must be used if DE7081 contains an GS1 code.
	C273	Item description		A		
	7009	Item description code	an..17	O		CU Consumer unit (GS1 Permanent Code) DU Despatch unit (GS1 Permanent Code) RC Returnable container (GS1 Permanent Code) SER Service (GS1 Permanent Code) TU Traded unit (GS1 Permanent Code) VQ Variable quantity product (GS1 Permanent Code)
	1131	Code list identification code	an..17	O		
	3055	Code list responsible agency code	an..3	D		9 GS1 91 Assigned by supplier or supplier's agent 92 Assigned by buyer or buyer's agent
		Item description				

Max. Occ. = Maximum Occurrence, St = Status, * = Restricted Codes
 Status: M=Mandatory, R=Required, O=Optional, C=Conditional, D=Dependent, A=Advised, N=Not used

Segment Layout

Business Term	DE	EDIFACT	Format	St	*	Description
	7008		an..25	O		
	7008	Item description	an..25	O		
	3453	Language name code	an..3	O		

This segment is used to provide a description for the current line item.

It is recommended that this segment only be used for coded descriptions. Data element 7008 in clear text should only be used when no product code is available or when free-form descriptions are required by trading partners to communicate basic product descriptions.

GS1 recommends that free text product description be provided in the EANCOM price/sales catalogue (PRICAT) and there after referred to using a GTIN.

If you wish to indicate that promotional details are marked on the package, then this should be indicated in DE 7233 in the PAC segment.

Example:

Example: `IMD+C+2:23:9+CU:23:9:BEXTARTAR:B:AA'`

Example: `IMD+C++TU::9'`

Example: `IMD+F++:::CORN CRUNCHIES:CASE'`

Max. Occ. = Maximum Occurrence, St = Status, * = Restricted Codes

Status: M=Mandatory, R=Required, O=Optional, C=Conditional, D=Dependent, A=Advised, N=Not used

Segment Layout

No. Seg	St	Max. Occ.				
SG26	C	9999999	LIN-PIA-IMD-MEA-QTY-ALI-DTM-GIN-QVR-FTX-SG27-SG28-SG29-SG30-SG31-SG33-SG34-SG35-SG39-SG45-SG47			
A group of segments providing details of the individual invoiced items. There must be at least one occurrence of Segment group 26 within an invoice, but not necessarily in a credit note or a debit note. This Segment group may be repeated to give sub-line details.						
44	MEA	C	5	Measurements		
To specify physical measurements, including dimension tolerances, weights and counts.						
Business Term	DE	EDIFACT	Format	St	*	Description
	6311	Measurement purpose code qualifier	an..3	M		PD Physical dimensions (product ordered) SO Storage limitation TL Transportation equipment limitations
	C502	Measurement details		A		
	6313	Measured attribute code	an..3	A		AAA Unit net weight ACG Chargeable weight HT Height dimension LN Length dimension WD Width dimension
	6321	Measurement significance code	an..3	O		3 Approximately 4 Equal to
	C174	Value/range		R		
	6411	Measurement unit code	an..3	M		
	6314	Measurement value	an..18	O		
	6162	Range minimum value	n..18	O		
	6152	Range maximum value	n..18	O		
	6432	Significant digits quantity	n..2	O		
<p>This segment is used to specify the physical dimensions, storage limitations, or transport equipment limitations of a product.</p> <p>Example: Product with dimensions 500mm x 200mm x 100mm.</p> <p>Example: MEA+PD+AAA:4+KWT:5219:4000:7000:1'</p> <p>Example: MEA+PD+HT+MMT:500'</p> <p>Example: MEA+PD+LN+MMT:200'</p> <p>Example: MEA+PD+WD+MMT:100'</p>						

Max. Occ. = Maximum Occurrence, St = Status, * = Restricted Codes
 Status: M=Mandatory, R=Required, O=Optional, C=Conditional, D=Dependent, A=Advised, N=Not used

Segment Layout

No. Seg	St	Max. Occ.			
SG26	C	9999999	LIN-PIA-IMD-MEA-QTY-ALI-DTM-GIN-QVR-FTX-SG27-SG28-SG29-SG30-SG31-SG33-SG34-SG35-SG39-SG45-SG47		
A group of segments providing details of the individual invoiced items. There must be at least one occurrence of Segment group 26 within an invoice, but not necessarily in a credit note or a debit note. This Segment group may be repeated to give sub-line details.					
45	QTY	C 5	Quantity		
To specify a pertinent quantity.					
Business Term	DE	EDIFACT	Format	St	* Description
	C186	Quantity details		M	
	6063	Quantity type code qualifier	an..3	M	* 1 Discrete quantity 12 Despatch quantity 21 Ordered quantity 46 Delivered quantity 47 Invoiced quantity 59 Number of consumer units in the traded unit 61 Return quantity 192 Free goods quantity 194 Received and accepted 510 Minimum invoicing quantity 45E Number of units in higher packaging or configuration level (GS1 Temporary Code)
	6060	Quantity	an..35	M	
	6411	Measurement unit code	an..3	D	LNE Printed line count (GS1 Temporary Code)
<p>This segment is used to specify quantities related to the current line item. Example: Dependency Notes: DE 6411: This DE is only used if the product being invoiced is of variable quantity. Example: QTY+12:8354:C0' Example: QTY+47:40'</p>					

Max. Occ. = Maximum Occurrence, St = Status, * = Restricted Codes
 Status: M=Mandatory, R=Required, O=Optional, C=Conditional, D=Dependent, A=Advised, N=Not used

Segment Layout

No. Seg	St	Max. Occ.			
SG26	C	9999999	LIN-PIA-IMD-MEA-QTY-ALI-DTM-GIN-QVR-FTX-SG27-SG28-SG29-SG30-SG31-SG33-SG34-SG35-SG39-SG45-SG47		
A group of segments providing details of the individual invoiced items. There must be at least one occurrence of Segment group 26 within an invoice, but not necessarily in a credit note or a debit note. This Segment group may be repeated to give sub-line details.					
46	ALI	C	5	Additional information	
To indicate that special conditions due to the origin, customs preference, fiscal or commercial factors are applicable.					
Business Term	DE	EDIFACT	Format	St	* Description
	3239	Country of origin name code	an..3	O	Use ISO 3166 two alpha country code.
	9213	Duty regime type code	an..3	O	
	4183	Special condition code	an..3	O	6 Subject to bonus 15 Not subject to discount
	4183	Special condition code	an..3	O	
	4183	Special condition code	an..3	O	
	4183	Special condition code	an..3	O	
	4183	Special condition code	an..3	O	
This segment is used to indicate special conditions or the country of origin of the current line item. Example: Example: ALI+GB+1+1+1+1+1+1 ' Example: ALI+EU'					

Max. Occ. = Maximum Occurrence, St = Status, * = Restricted Codes
 Status: M=Mandatory, R=Required, O=Optional, C=Conditional, D=Dependent, A=Advised, N=Not used

Segment Layout

No. Seg	St	Max. Occ.				
SG26	C	9999999	LIN-PIA-IMD-MEA-QTY-ALI-DTM-GIN-QVR-FTX-SG27-SG28-SG29-SG30-SG31-SG33-SG34-SG35-SG39-SG45-SG47			
<p>A group of segments providing details of the individual invoiced items. There must be at least one occurrence of Segment group 26 within an invoice, but not necessarily in a credit note or a debit note. This Segment group may be repeated to give sub-line details.</p>						
47	DTM	C 35	Date/time/period			
<p>To specify date, and/or time, or period.</p>						
Business Term	DE	EDIFACT	Format	St	*	Description
	C507	Date/time/period		M		
	2005	Date or time or period function code qualifier	an..3	M	*	1 Service completion date/time, actual 11 Despatch date and/or time 35 Delivery date/time, actual 36 Expiry date 50 Goods receipt date/time 100 Product ageing period before delivery 263 Invoicing period 267 Rate/price date/time
	2380	Date or time or period value	an..35	R		
	2379	Date or time or period format code	an..3	R		102 CCYYMMDD 718 CCYYMMDD-CCYYMMDD
<p>This segment is used to specify the date of despatch, delivery, or receipt of the current line item. Example: Example: DTM+35:19930801:102 ' Example: DTM+35:20020801:102 '</p>						

Max. Occ. = Maximum Occurrence, St = Status, * = Restricted Codes
 Status: M=Mandatory, R=Required, O=Optional, C=Conditional, D=Dependent, A=Advised, N=Not used

Segment Layout

No. Seg	St	Max. Occ.				
SG26	C	9999999	LIN-PIA-IMD-MEA-QTY-ALI-DTM-GIN-QVR-FTX-SG27-SG28-SG29-SG30-SG31-SG33-SG34-SG35-SG39-SG45-SG47			
<p>A group of segments providing details of the individual invoiced items. There must be at least one occurrence of Segment group 26 within an invoice, but not necessarily in a credit note or a debit note. This Segment group may be repeated to give sub-line details.</p>						
48	GIN	C 1000	Goods identity number			
<p>To give specific identification numbers, either as single numbers or ranges.</p>						
Business Term	DE	EDIFACT	Format	St	*	Description
	7405	Object identification code qualifier	an..3	M	*	BN Serial number
	C208	Identity number range		M		
	7402	Object identifier	an..35	M		
	7402	Object identifier	an..35	O		
	C208	Identity number range		O		
	7402	Object identifier	an..35	M		
	7402	Object identifier	an..35	O		
	C208	Identity number range		O		
	7402	Object identifier	an..35	M		
	7402	Object identifier	an..35	O		
	C208	Identity number range		O		
	7402	Object identifier	an..35	M		
	7402	Object identifier	an..35	O		
	C208	Identity number range		O		
	7402	Object identifier	an..35	M		
	7402	Object identifier	an..35	O		
<p>This segment is used to indicate a serial number or a range of numbers. Example: Example: GIN+BN+X:X+X:X+X:X+X:X+X:X' Example: GIN+BN+AS-1299:AS-1350'</p>						

Max. Occ. = Maximum Occurrence, St = Status, * = Restricted Codes
 Status: M=Mandatory, R=Required, O=Optional, C=Conditional, D=Dependent, A=Advised, N=Not used

Segment Layout

No. Seg	St	Max. Occ.				
SG26	C	9999999	LIN-PIA-IMD-MEA-QTY-ALI-DTM-GIN-QVR-FTX-SG27-SG28-SG29-SG30-SG31-SG33-SG34-SG35-SG39-SG45-SG47			
<p>A group of segments providing details of the individual invoiced items. There must be at least one occurrence of Segment group 26 within an invoice, but not necessarily in a credit note or a debit note. This Segment group may be repeated to give sub-line details.</p>						
49	QVR	C 1	Quantity variances			
<p>To specify item details relating to quantity variances.</p>						
Business Term	DE	EDIFACT	Format	St	*	Description
	C279	Quantity difference information		R		
	6064	Quantity variance value	n..15	M		Specify the actual variance amount here.
	6063	Quantity type code qualifier	an..3	R	*	12 Despatch quantity 21 Ordered quantity 61 Return quantity 119 Short shipped 121 Over shipped 124 Damaged goods
	4221	Discrepancy nature identification code	an..3	O		BP Shipment partial - back order to follow CP Shipment partial - considered complete, no backorder OW Item out of stock at wholesaler TW Item temporarily discontinued by wholesaler
	C960	Reason for change		O		
	4295	Change reason description code	an..3	O		AJT Adjustment (GS1 Temporary Code)
	1131	Code list identification code	an..17	O		
	3055	Code list responsible agency code	an..3	D		9 GS1
	4294	Change reason description	an..35	O		
<p>This segment is used to specify any variances between what was ordered, what was shipped/despatched and what is being invoiced. For negative values (e.g. damaged goods not accepted) the variance must be expressed as negative. Example: This example shows a variance of 20 between what is being invoiced (QTY at LIN level) and what was originally ordered. Example: QVR+40:12+BP+AJT:23:9:1' Example: QVR+-20:21'</p>						

Max. Occ. = Maximum Occurrence, St = Status, * = Restricted Codes
 Status: M=Mandatory, R=Required, O=Optional, C=Conditional, D=Dependent, A=Advised, N=Not used

Segment Layout

No. Seg	St	Max. Occ.	
SG26	C	9999999	LIN-PIA-IMD-MEA-QTY-ALI-DTM-GIN-QVR-FTX-SG27-SG28-SG29-SG30-SG31-SG33-SG34-SG35-SG39-SG45-SG47
A group of segments providing details of the individual invoiced items. There must be at least one occurrence of Segment group 26 within an invoice, but not necessarily in a credit note or a debit note. This Segment group may be repeated to give sub-line details.			
50	FTX	C 99	Free text To provide free form or coded text information.

Business Term	DE	EDIFACT	Format	St	*	Description
	4451	Text subject code qualifier	an..3	M		BAQ VAT exemption reason CHG Change information ZZZ Mutually defined
	4453	Free text function code	an..3	O	*	1 Text for subsequent use
	C107	Text reference		D		This composite is only used when trading partners have agreed to use mutually defined code values.
	4441	Free text value code	an..17	M		002 = Standard text code.....
	1131	Code list identification code	an..17	O		
	3055	Code list responsible agency code	an..3	D		91 Assigned by supplier or supplier's agent 92 Assigned by buyer or buyer's agent
	C108	Text literal		D		This composite is only used if coded text can not be used.
	4440	Free text value	an..51	M		
	4440	Free text value	an..51	O		
	4440	Free text value	an..51	O		
	4440	Free text value	an..51	O		
	4440	Free text value	an..51	O		
	3453	Language name code	an..3	D		ISO 639 two alpha code This data element is only used when non coded free text has been provided in data element C108

This segment is used to provide free form or coded text information which applies to the current line item.

The use of the FTX segment in free form is not recommended since in most cases it inhibits automatic processing of the Invoice. Coded references to standard texts is an available functionality which enables automatic processing and reduces transmission and processing overheads. Standard texts should be mutually defined among trading partners and can be used to cover legal or other requirements.

Example:

Max. Occ. = Maximum Occurrence, St = Status, * = Restricted Codes
 Status: M=Mandatory, R=Required, O=Optional, C=Conditional, D=Dependent, A=Advised, N=Not used

Segment Layout

e.g. Standard Text Code 002 = 'Missing items will be shipped next week.'

Example: FTX+CHG+1+002:132:9+A:B:C:D:E+EN'

Example: FTX+ZZZ+1+002::91'

Max. Occ. = Maximum Occurrence, St = Status, * = Restricted Codes

Status: M=Mandatory, R=Required, O=Optional, C=Conditional, D=Dependent, A=Advised, N=Not used

Segment Layout

No. Seg	St	Max. Occ.				
SG26	C	9999999	LIN-PIA-IMD-MEA-QTY-ALI-DTM-GIN-QVR-FTX-SG27-SG28-SG29-SG30-SG31-SG33-SG34-SG35-SG39-SG45-SG47			
<p>A group of segments providing details of the individual invoiced items. There must be at least one occurrence of Segment group 26 within an invoice, but not necessarily in a credit note or a debit note. This Segment group may be repeated to give sub-line details.</p>						
SG27	C	99	MOA			
<p>A group of segments specifying any monetary amounts relating to the products and when necessary a currency.</p>						
51	MOA	M	1	Monetary amount		
<p>To specify a monetary amount.</p>						
Business Term	DE	EDIFACT	Format	St	*	Description
	C516	Monetary amount		M		
	5025	Monetary amount type code qualifier	an..3	M		203 Line item amount 227 Deposit 388 Total amount including Value Added Tax (VAT) 496 Total returnable packages deposit amount 505 Rental amount X41 Total returnable items rental fee amount (GS1 Temporary Code) X42 Rental fee (GS1 Temporary Code)
	5004	Monetary amount	n..35	R		
	6345	Currency identification code	an..3	O		ISO 4217 three alpha
	6343	Currency type code qualifier	an..3	O	*	4 Invoicing currency 10 Pricing currency 11 Payment currency
<p>This segment is used to specify monetary amounts related to the current line item. Item Amount = Quantity * Unit Net Price Item Amount = (Quantity * Unit Gross Price) + Charges - Allowances Example: This example shows the line item amount as 580. This figure is derived from multiplying the invoiced quantity, 40, by the price 14.50. Example: MOA+203:14562.32:GBP:4' Example: MOA+203:580'</p>						

Max. Occ. = Maximum Occurrence, St = Status, * = Restricted Codes
 Status: M=Mandatory, R=Required, O=Optional, C=Conditional, D=Dependent, A=Advised, N=Not used

Segment Layout

No. Seg	St	Max. Occ.	
SG26	C	9999999	LIN-PIA-IMD-MEA-QTY-ALI-DTM-GIN-QVR-FTX-SG27-SG28-SG29-SG30-SG31-SG33-SG34-SG35-SG39-SG45-SG47
A group of segments providing details of the individual invoiced items. There must be at least one occurrence of Segment group 26 within an invoice, but not necessarily in a credit note or a debit note. This Segment group may be repeated to give sub-line details.			
SG28	C	10	PAT-DTM-PCD-MOA
A group of segments specifying the terms of payment for the line item where this is different to that specified in the heading section.			
52	PAT	M 1	Payment terms basis
To specify the payment terms basis.			
Notes:			
1. This segment will be removed effective with directory D.02B.			

Business Term	DE	EDIFACT	Format	St	*	Description
	4279	Payment terms type code qualifier	an..3	M		1 Basic 3 Fixed date 7 Extended 20 Penalty terms 22 Discount ZZZ Mutually defined
	C110	Payment terms		N		
	4277	Payment terms description identifier	an..17			
	C112	Terms/time information		O		
	2475	Time reference code	an..3	M		5 Date of invoice 52 Due date of negotiable instrument
	2009	Terms time relation code	an..3	O		3 After reference
	2151	Period type code	an..3	O		D Day M Month WD Working days Y Year
	2152	Period count quantity	n..3	O		

This segment is used to identify specific payment terms for the current line item.

Example:

The following example indicates extended payment terms with payment due 90 days after the reference date which is the invoice date.

Example: PAT+1++5:1:D:12'

Example: PAT+7++5:3:D:90'

Max. Occ. = Maximum Occurrence, St = Status, * = Restricted Codes

Status: M=Mandatory, R=Required, O=Optional, C=Conditional, D=Dependent, A=Advised, N=Not used

Segment Layout

No. Seg	St	Max. Occ.				
SG26	C	9999999	LIN-PIA-IMD-MEA-QTY-ALI-DTM-GIN-QVR-FTX-SG27-SG28-SG29-SG30-SG31-SG33-SG34-SG35-SG39-SG45-SG47			
A group of segments providing details of the individual invoiced items. There must be at least one occurrence of Segment group 26 within an invoice, but not necessarily in a credit note or a debit note. This Segment group may be repeated to give sub-line details.						
SG28	C	10	PAT-DTM-PCD-MOA			
A group of segments specifying the terms of payment for the line item where this is different to that specified in the heading section.						
53	DTM	C	5	Date/time/period		
To specify date, and/or time, or period.						
Business Term	DE	EDIFACT	Format	St	*	Description
	C507	Date/time/period		M		
	2005	Date or time or period function code qualifier	an..3	M		12 Terms discount due date/time 13 Terms net due date 140 Payment due date 209 Value date
	2380	Date or time or period value	an..35	R		
	2379	Date or time or period format code	an..3	R		102 CCYYMMDD 718 CCYYMMDD- CCYYMMDD
This segment is used to specify any dates associated with the payment terms provided in the previous PAT segment. Example: Example: DTM+13:19930830:102' Example: DTM+13:20020830:102'						

Max. Occ. = Maximum Occurrence, St = Status, * = Restricted Codes
Status: M=Mandatory, R=Required, O=Optional, C=Conditional, D=Dependent, A=Advised, N=Not used

Segment Layout

No. Seg	St	Max. Occ.				
SG26	C	9999999	LIN-PIA-IMD-MEA-QTY-ALI-DTM-GIN-QVR-FTX-SG27-SG28-SG29-SG30-SG31-SG33-SG34-SG35-SG39-SG45-SG47			
<p>A group of segments providing details of the individual invoiced items. There must be at least one occurrence of Segment group 26 within an invoice, but not necessarily in a credit note or a debit note. This Segment group may be repeated to give sub-line details.</p>						
SG28	C	10	PAT-DTM-PCD-MOA			
<p>A group of segments specifying the terms of payment for the line item where this is different to that specified in the heading section.</p>						
54	PCD	C 99	Percentage details			
<p>To specify percentage information.</p>						
Business Term	DE	EDIFACT	Format	St	*	Description
	C501	Percentage details		M		
	5245	Percentage type code qualifier	an..3	M		12 Discount 15 Penalty percentage
	5482	Percentage	n..10	R		
<p>This segment specifies the penalty or discount percentage applicable for the terms of payment defined in the PAT segment. Example: Example: PCD+7:1.5' Example: PCD+12:2.5'</p>						

Max. Occ. = Maximum Occurrence, St = Status, * = Restricted Codes
Status: M=Mandatory, R=Required, O=Optional, C=Conditional, D=Dependent, A=Advised, N=Not used

Segment Layout

No. Seg	St	Max. Occ.				
SG26	C	9999999	LIN-PIA-IMD-MEA-QTY-ALI-DTM-GIN-QVR-FTX-SG27-SG28-SG29-SG30-SG31-SG33-SG34-SG35-SG39-SG45-SG47			
<p>A group of segments providing details of the individual invoiced items. There must be at least one occurrence of Segment group 26 within an invoice, but not necessarily in a credit note or a debit note. This Segment group may be repeated to give sub-line details.</p>						
SG28	C	10	PAT-DTM-PCD-MOA			
<p>A group of segments specifying the terms of payment for the line item where this is different to that specified in the heading section.</p>						
55	MOA	C 1	Monetary amount			
<p>To specify a monetary amount.</p>						
Business Term	DE	EDIFACT	Format	St	*	Description
	C516	Monetary amount		M		
	5025	Monetary amount type code qualifier	an..3	M		52 Discount amount 201 Penalty amount
	5004	Monetary amount	n..35	R		
<p>This segment specifies the penalty or discount monetary amount applicable for the terms of payment defined in the PAT segment. Example: Example: MOA+8:12.50' Example: MOA+201:100'</p>						

Max. Occ. = Maximum Occurrence, St = Status, * = Restricted Codes
Status: M=Mandatory, R=Required, O=Optional, C=Conditional, D=Dependent, A=Advised, N=Not used

Segment Layout

No. Seg	St	Max. Occ.	
SG26	C	9999999	LIN-PIA-IMD-MEA-QTY-ALI-DTM-GIN-QVR-FTX-SG27-SG28-SG29-SG30-SG31-SG33-SG34-SG35-SG39-SG45-SG47
<p>A group of segments providing details of the individual invoiced items. There must be at least one occurrence of Segment group 26 within an invoice, but not necessarily in a credit note or a debit note. This Segment group may be repeated to give sub-line details.</p>			
SG29	C	25	PRI-APR
<p>A group of segments identifying the relevant pricing information for the goods or services invoiced.</p>			
56	PRI	M 1	Price details To specify price information.

Business Term	DE	EDIFACT	Format	St	*	Description
	C509	Price information		R		
	5125	Price code qualifier	an..3	M		AAA Calculation net AAB Calculation gross AAE Information price, excluding allowances or charges, including taxes AAF Information price, excluding allowances or charges and taxes AAH Subject to escalation and price adjustment AAQ Firm price ABL Base price ABM Base price difference
	5118	Price amount	n..15	R		
	5375	Price type code	an..3	O		CA Catalogue CT Contract
	5387	Price specification code	an..3	O		DPR Discount price PPR Provisional price PRP Promotional price RTP Retail price SRP Suggested retail price
	5284	Unit price basis value	n..9	D		
	6411	Measurement unit code	an..3	D		

This segment is used to specify price information for the current line item.

Example:

For all the following examples the invoicing currency has already been identified as Pounds Sterling.

Net price of 14.50 (excluding tax) to be used for calculation purposes. This price includes all allowances and charges. The price is a catalogue price.

Max. Occ. = Maximum Occurrence, St = Status, * = Restricted Codes

Status: M=Mandatory, R=Required, O=Optional, C=Conditional, D=Dependent, A=Advised, N=Not used

Segment Layout

Gross calculation price of 25 (excluding tax) which does not include any allowances or charges. The price is a contract price.

Price of 2.56 is a suggested retail price from the catalogue which does not include any allowances or charges but includes taxes.

Price of 4.20 is a retail price from the catalogue which does not include allowances, charges or taxes.

Dependency Notes:

Data elements 5284 and 6411 are used when a product is a variable quantity product, e.g. price per 200 kilos, or when the unit of measure for purchasing, delivery, and invoicing are different for a product, e.g. sugar is not a variable quantity product but ordered and delivered in packs, and invoiced in kilos or tonnes.

Example: PRI+AAA:1235.20:CT:AAE:1:KWT'

Example: PRI+AAA:14.50:CA'

Example: PRI+AAB:25:CT'

Example: PRI+AAE:2.56:CA:SRP'

Example: PRI+AAF:4.20:CA:RTP'

Max. Occ. = Maximum Occurrence, St = Status, * = Restricted Codes

Status: M=Mandatory, R=Required, O=Optional, C=Conditional, D=Dependent, A=Advised, N=Not used

Segment Layout

No. Seg	St	Max. Occ.	
SG26	C	9999999	LIN-PIA-IMD-MEA-QTY-ALI-DTM-GIN-QVR-FTX-SG27-SG28-SG29-SG30-SG31-SG33-SG34-SG35-SG39-SG45-SG47
<p>A group of segments providing details of the individual invoiced items. There must be at least one occurrence of Segment group 26 within an invoice, but not necessarily in a credit note or a debit note. This Segment group may be repeated to give sub-line details.</p>			
SG29	C	25	PRI-APR
<p>A group of segments identifying the relevant pricing information for the goods or services invoiced.</p>			
57	APR	C 1	Additional price information
<p>To provide information concerning pricing related to class of trade, price multiplier, and reason for change.</p>			

Business Term	DE	EDIFACT	Format	St	*	Description
	4043	Trade class code	an..3	O		MF Manufacturer
	C138	Price multiplier information		R		
	5394	Price multiplier rate	n..12	M		
	5393	Price multiplier type code qualifier	an..3	R		A Price adjustment coefficient
	C960	Reason for change		A		
	4295	Change reason description code	an..3	R	*	X29 Government price charge (GS1 Temporary Code)
	1131	Code list identification code	an..17	N		
	3055	Code list responsible agency code	an..3	O		
	4294	Change reason description	an..35	O		

This segment is used to provide a reason for a change in the price specified in the PRI segment.
 Example:

Example: APR+CR+123456789012:A+X29::2:ABCD '
 Example: APR+MF+0.95:A+X29 '

Max. Occ. = Maximum Occurrence, St = Status, * = Restricted Codes
 Status: M=Mandatory, R=Required, O=Optional, C=Conditional, D=Dependent, A=Advised, N=Not used

Segment Layout

No. Seg	St	Max. Occ.			
SG26	C	9999999	LIN-PIA-IMD-MEA-QTY-ALI-DTM-GIN-QVR-FTX-SG27-SG28-SG29-SG30-SG31-SG33-SG34-SG35-SG39-SG45-SG47		
A group of segments providing details of the individual invoiced items. There must be at least one occurrence of Segment group 26 within an invoice, but not necessarily in a credit note or a debit note. This Segment group may be repeated to give sub-line details.					
SG30	C	10	RFF-DTM		
A group giving references and where necessary, their dates, relating to the line item.					
58	RFF	M	1	Reference	
To specify a reference.					
Business Term	DE	EDIFACT	Format	St	* Description
	C506	Reference		M	
	1153	Reference code qualifier	an..3	M	AAK Despatch advice number ALO Receiving advice number CR Customer reference number CT Contract number DQ Delivery note number IP Import licence number ON Order number (buyer) PL Price list number RF Export reference number SZ Specification number VN Order number (supplier)
	1154	Reference identifier	an..70	R	
	1156	Document line identifier	an..6	O	
This segment is used to provide references specific to the line item, and overrides any global references provided in the heading section of the invoice when the same qualifier is used. Example: Example: RFF+AAK:8306:1' Example: RFF+AAK:8306'					

Max. Occ. = Maximum Occurrence, St = Status, * = Restricted Codes
Status: M=Mandatory, R=Required, O=Optional, C=Conditional, D=Dependent, A=Advised, N=Not used

Segment Layout

No. Seg	St	Max. Occ.				
SG26	C	9999999	LIN-PIA-IMD-MEA-QTY-ALI-DTM-GIN-QVR-FTX-SG27-SG28-SG29-SG30-SG31-SG33-SG34-SG35-SG39-SG45-SG47			
A group of segments providing details of the individual invoiced items. There must be at least one occurrence of Segment group 26 within an invoice, but not necessarily in a credit note or a debit note. This Segment group may be repeated to give sub-line details.						
SG30	C	10	RFF-DTM			
A group giving references and where necessary, their dates, relating to the line item.						
59	DTM	C	5	Date/time/period		
To specify date, and/or time, or period.						
Business Term	DE	EDIFACT	Format	St	*	Description
	C507	Date/time/period		M		
	2005	Date or time or period function code qualifier	an..3	M	*	171 Reference date/time
	2380	Date or time or period value	an..35	R		
	2379	Date or time or period format code	an..3	R		102 CCYYMMDD
This segment is used to specify dates and times pertinent to the previous RFF segment. Example: Example: DTM+171:19930802:102' Example: DTM+171:20020802:102'						

Max. Occ. = Maximum Occurrence, St = Status, * = Restricted Codes
Status: M=Mandatory, R=Required, O=Optional, C=Conditional, D=Dependent, A=Advised, N=Not used

Segment Layout

No. Seg	St	Max. Occ.				
SG26	C	9999999	LIN-PIA-IMD-MEA-QTY-ALI-DTM-GIN-QVR-FTX-SG27-SG28-SG29-SG30-SG31-SG33-SG34-SG35-SG39-SG45-SG47			
<p>A group of segments providing details of the individual invoiced items. There must be at least one occurrence of Segment group 26 within an invoice, but not necessarily in a credit note or a debit note. This Segment group may be repeated to give sub-line details.</p>						
SG31	C	10	PAC-MEA-SG32			
<p>A group of segments identifying the packaging, physical dimensions, and marks and numbers for goods referenced in the line item.</p>						
60	PAC	M 1	Package			
<p>To describe the number and type of packages/physical units.</p>						
Business Term	DE	EDIFACT	Format	St	*	Description
	7224	Package quantity	n..8	O		
	C531	Packaging details		O		
	7075	Packaging level code	an..3	O		
	7233	Packaging related description code	an..3	O		
	7073	Packaging terms and conditions code	an..3	O		1 Packaging cost paid by supplier 2 Packaging cost paid by recipient 3 Packaging cost not charged (returnable)
	C202	Package type		O		
	7065	Package type description code	an..17	A		
	1131	Code list identification code	an..17	O		
	3055	Code list responsible agency code	an..3	D		
	7064	Type of packages	an..35	O		
	C402	Package type identification		N		
	7077	Description format code	an..3			
	C532	Returnable package details		D		Composite C532 is only used where the packaging being described is returnable. This composite identifies who is responsible for payment of its return.
	8395	Returnable package freight payment responsibility code	an..3	O		1 Paid by customer 3 Paid by supplier
<p>This segment is used to specify the number and type of packages for the current line item. Example:</p>						

Max. Occ. = Maximum Occurrence, St = Status, * = Restricted Codes
 Status: M=Mandatory, R=Required, O=Optional, C=Conditional, D=Dependent, A=Advised, N=Not used

Segment Layout

Example: PAC+1+1:1:3+AE:23:6:A++1'

Example: PAC+++CR++3'

Segment Layout

No. Seg	St	Max. Occ.				
SG26	C	9999999	LIN-PIA-IMD-MEA-QTY-ALI-DTM-GIN-QVR-FTX-SG27-SG28-SG29-SG30-SG31-SG33-SG34-SG35-SG39-SG45-SG47			
<p>A group of segments providing details of the individual invoiced items. There must be at least one occurrence of Segment group 26 within an invoice, but not necessarily in a credit note or a debit note. This Segment group may be repeated to give sub-line details.</p>						
SG31	C	10	PAC-MEA-SG32			
<p>A group of segments identifying the packaging, physical dimensions, and marks and numbers for goods referenced in the line item.</p>						
61	MEA	C	10	Measurements		
<p>To specify physical measurements, including dimension tolerances, weights and counts.</p>						
Business Term	DE	EDIFACT	Format	St	*	Description
	6311	Measurement purpose code qualifier	an..3	M		PD Physical dimensions (product ordered) SO Storage limitation TL Transportation equipment limitations
	C502	Measurement details		A		
	6313	Measured attribute code	an..3	A		AAA Unit net weight HT Height dimension LN Length dimension WD Width dimension
	6321	Measurement significance code	an..3	O		3 Approximately 4 Equal to
	C174	Value/range		R		
	6411	Measurement unit code	an..3	M		
	6314	Measurement value	an..18	O		
	6162	Range minimum value	n..18	O		
	6152	Range maximum value	n..18	O		
	6432	Significant digits quantity	n..2	O		
<p>This segment is used to specify any measurements related to the packaging defined in the previous PAC segment. Example: The net weight of the package is 400 kilograms. Example: MEA+AAB+A:3+KGM:2:2:2:1' Example: MEA+PD+AAA:4+KGM:400'</p>						

Max. Occ. = Maximum Occurrence, St = Status, * = Restricted Codes
 Status: M=Mandatory, R=Required, O=Optional, C=Conditional, D=Dependent, A=Advised, N=Not used

Segment Layout

No. Seg	St	Max. Occ.	
SG26	C	9999999	LIN-PIA-IMD-MEA-QTY-ALI-DTM-GIN-QVR-FTX-SG27-SG28-SG29-SG30-SG31-SG33-SG34-SG35-SG39-SG45-SG47
<p>A group of segments providing details of the individual invoiced items. There must be at least one occurrence of Segment group 26 within an invoice, but not necessarily in a credit note or a debit note. This Segment group may be repeated to give sub-line details.</p>			
SG31	C	10	PAC-MEA-SG32
<p>A group of segments identifying the packaging, physical dimensions, and marks and numbers for goods referenced in the line item.</p>			
SG32	C	10	PCI-GIN
<p>A group of segments specifying the markings and labels on individual physical units.</p>			
62	PCI	M 1	Package identification
<p>To specify markings and labels on individual packages or physical units.</p>			
Business Term	DE	EDIFACT	Format St * Description
	4233	Marking instructions code	an..3 R 39 Marked with Serial Shipping Container Code (SSCC)
	C210	Marks & labels	O
	7102	Shipping marks description	an..35 M
	7102	Shipping marks description	an..35 O
	7102	Shipping marks description	an..35 O
	7102	Shipping marks description	an..35 O
	7102	Shipping marks description	an..35 O
	7102	Shipping marks description	an..35 O
	7102	Shipping marks description	an..35 O
	7102	Shipping marks description	an..35 O
	7102	Shipping marks description	an..35 O
	7102	Shipping marks description	an..35 O
<p>This segment is used to identify markings on the packaging of the product being invoiced. Example: Example: PCI+39+1:12:1:1:1:1:1:1:1:1' Example: PCI+39'</p>			

Max. Occ. = Maximum Occurrence, St = Status, * = Restricted Codes
 Status: M=Mandatory, R=Required, O=Optional, C=Conditional, D=Dependent, A=Advised, N=Not used

Segment Layout

No. Seg	St	Max. Occ.	
SG26	C	9999999	LIN-PIA-IMD-MEA-QTY-ALI-DTM-GIN-QVR-FTX-SG27-SG28-SG29-SG30-SG31-SG33-SG34-SG35-SG39-SG45-SG47
A group of segments providing details of the individual invoiced items. There must be at least one occurrence of Segment group 26 within an invoice, but not necessarily in a credit note or a debit note. This Segment group may be repeated to give sub-line details.			
SG31	C	10	PAC-MEA-SG32
A group of segments identifying the packaging, physical dimensions, and marks and numbers for goods referenced in the line item.			
SG32	C	10	PCI-GIN
A group of segments specifying the markings and labels on individual physical units.			
63	GIN	C 10	Goods identity number
To give specific identification numbers, either as single numbers or ranges.			

Business Term	DE	EDIFACT	Format	St	*	Description
	7405	Object identification code qualifier	an..3	M	*	AW Serial shipping container code BJ Serial shipping container code
	C208	Identity number range		M		
	7402	Object identifier	an..35	M		
	7402	Object identifier	an..35	O		
	C208	Identity number range		O		
	7402	Object identifier	an..35	M		
	7402	Object identifier	an..35	O		
	C208	Identity number range		O		
	7402	Object identifier	an..35	M		
	7402	Object identifier	an..35	O		
	C208	Identity number range		O		
	7402	Object identifier	an..35	M		
	7402	Object identifier	an..35	O		
	C208	Identity number range		O		
	7402	Object identifier	an..35	M		
	7402	Object identifier	an..35	O		

This segment is used to provide the serial shipping container code (SSCC) marked on the packaging of the products being invoiced.

Example:

Example: GIN+AW+1:1+1:1+1:1+1:1+12:1'

Example: GIN+AW+35412345000000014'

Max. Occ. = Maximum Occurrence, St = Status, * = Restricted Codes

Status: M=Mandatory, R=Required, O=Optional, C=Conditional, D=Dependent, A=Advised, N=Not used

Segment Layout

No. Seg	St	Max. Occ.				
SG26	C	9999999	LIN-PIA-IMD-MEA-QTY-ALI-DTM-GIN-QVR-FTX-SG27-SG28-SG29-SG30-SG31-SG33-SG34-SG35-SG39-SG45-SG47			
<p>A group of segments providing details of the individual invoiced items. There must be at least one occurrence of Segment group 26 within an invoice, but not necessarily in a credit note or a debit note. This Segment group may be repeated to give sub-line details.</p>						
SG33	C	9999	LOC-QTY-DTM			
<p>A group of segments specifying destination and quantity details for consignments involving multi-destination deliveries for a specified line item.</p>						
64	LOC	M 1	Place/location identification			
<p>To identify a place or a location and/or related locations.</p>						
Business Term	DE	EDIFACT	Format	St	*	Description
	3227	Location function code qualifier	an..3	M		7 Place of delivery
	C517	Location identification		A		
	3225	Location name code	an..25	A		GLN - Format n13
	1131	Code list identification code	an..17	O		
	3055	Code list responsible agency code	an..3	D		9 GS1 DE 3055 must be used if DE 3225 is used and does not contain an UN/LOCODE.
	3224	Location name	an..25	O		
	C519	Related location one identification		O		
	3223	First related location name code	an..25	O		Global Location Number GLN - Format n13
	1131	Code list identification code	an..17	O		
	3055	Code list responsible agency code	an..3	D		DE 3055 must be used if DE 3223 is used and does not contain an UN/LOCODE. 9 GS1
	3222	First related location name	an..70	O		
<p>This segment is used to identify multiple delivery locations for the current line item. Example: Example: LOC+7+4012345500000:23:9:A+:23:6:1' Example: LOC+7+4012345500004: :9'</p>						

Max. Occ. = Maximum Occurrence, St = Status, * = Restricted Codes
 Status: M=Mandatory, R=Required, O=Optional, C=Conditional, D=Dependent, A=Advised, N=Not used

Segment Layout

No. Seg	St	Max. Occ.				
SG26	C	9999999	LIN-PIA-IMD-MEA-QTY-ALI-DTM-GIN-QVR-FTX-SG27-SG28-SG29-SG30-SG31-SG33-SG34-SG35-SG39-SG45-SG47			
<p>A group of segments providing details of the individual invoiced items. There must be at least one occurrence of Segment group 26 within an invoice, but not necessarily in a credit note or a debit note. This Segment group may be repeated to give sub-line details.</p>						
SG33	C	9999	LOC-QTY-DTM			
<p>A group of segments specifying destination and quantity details for consignments involving multi-destination deliveries for a specified line item.</p>						
65	QTY	C 100	Quantity			
<p>To specify a pertinent quantity.</p>						
Business Term	DE	EDIFACT	Format	St	*	Description
	C186	Quantity details		M		
	6063	Quantity type code qualifier	an..3	M		47 Invoiced quantity 131 Delivery quantity 192 Free goods quantity
	6060	Quantity	an..35	M		
	6411	Measurement unit code	an..3	D		This DE is only used if the product being invoiced is of variable quantity.
<p>This segment is used to specify the quantities related to the location identified in the preceding LOC segment. The total of all QTY segments in SG33 should equal the value in the QTY at line level. Example: Example: QTY+131:1234:KWT ' Example: QTY+131:12 '</p>						

Max. Occ. = Maximum Occurrence, St = Status, * = Restricted Codes
Status: M=Mandatory, R=Required, O=Optional, C=Conditional, D=Dependent, A=Advised, N=Not used

Segment Layout

No. Seg	St	Max. Occ.				
SG26	C	9999999	LIN-PIA-IMD-MEA-QTY-ALI-DTM-GIN-QVR-FTX-SG27-SG28-SG29-SG30-SG31-SG33-SG34-SG35-SG39-SG45-SG47			
A group of segments providing details of the individual invoiced items. There must be at least one occurrence of Segment group 26 within an invoice, but not necessarily in a credit note or a debit note. This Segment group may be repeated to give sub-line details.						
SG33	C	9999	LOC-QTY-DTM			
A group of segments specifying destination and quantity details for consignments involving multi-destination deliveries for a specified line item.						
66	DTM	C	5	Date/time/period		
To specify date, and/or time, or period.						
Business Term	DE	EDIFACT	Format	St	*	Description
	C507	Date/time/period		M		
	2005	Date or time or period function code qualifier	an..3	M	*	35 Delivery date/ time, actual
	2380	Date or time or period value	an..35	R		
	2379	Date or time or period format code	an..3	R		102 CCYYMMDD 203 CCYYMMDDHHMM 718 CCYYMMDD- CCYYMMDD
This segment is used to specify the date/time on which the delivery took (will take) place to the location identified in preceding LOC segment. Example: Example: DTM+35:19930602:102' Example: DTM+35:20020602:102'						

Max. Occ. = Maximum Occurrence, St = Status, * = Restricted Codes
 Status: M=Mandatory, R=Required, O=Optional, C=Conditional, D=Dependent, A=Advised, N=Not used

Segment Layout

No. Seg	St	Max. Occ.	
SG26	C	9999999	LIN-PIA-IMD-MEA-QTY-ALI-DTM-GIN-QVR-FTX-SG27-SG28-SG29-SG30-SG31-SG33-SG34-SG35-SG39-SG45-SG47
A group of segments providing details of the individual invoiced items. There must be at least one occurrence of Segment group 26 within an invoice, but not necessarily in a credit note or a debit note. This Segment group may be repeated to give sub-line details.			
SG34	C	99	TAX-MOA
A group of segments specifying tax related information for the line item.			
67	TAX	M 1	Duty/tax/fee details
To specify relevant duty/tax/fee information.			

Business Term	DE	EDIFACT	Format	St	*	Description
	5283	Duty or tax or fee function code qualifier	an..3	M		5 Customs duty 7 Tax
	C241	Duty/tax/fee type		D		
	5153	Duty or tax or fee type name code	an..3	O		GST Goods and services tax VAT Value added tax
	1131	Code list identification code	an..17	O		
	3055	Code list responsible agency code	an..3	D		
	5152	Duty or tax or fee type name	an..35	O		
	C533	Duty/tax/fee account detail		O		
	5289	Duty or tax or fee account code	an..6	M		
	1131	Code list identification code	an..17	O		
	3055	Code list responsible agency code	an..3	D		
	5286	Duty or tax or fee assessment basis value	an..15	O		
	C243	Duty/tax/fee detail		A		
	5279	Duty or tax or fee rate code	an..7	O		
	1131	Code list identification code	an..17	O		
	3055	Code list responsible agency code	an..3	D		
	5278	Duty or tax or fee rate	an..17	R		The actual rate of tax/duty.
	5273	Duty or tax or fee rate basis code	an..12	O		2 Weight 3 Quantity
	1131	Code list identification code	an..17	O		
	3055	Code list responsible agency code	an..3	D		
	5305	Duty or tax or fee category code	an..3	D		A Mixed tax rate E Exempt from tax

Max. Occ. = Maximum Occurrence, St = Status, * = Restricted Codes
 Status: M=Mandatory, R=Required, O=Optional, C=Conditional, D=Dependent, A=Advised, N=Not used

Segment Layout

Business Term	DE	EDIFACT	Format	St	*	Description
						S Standard rate
	3446	Party tax identifier	an..20	O		

This segment is used to specify tax details for the line item being invoiced.

Example:

Dependency Notes:

DE C241 and 5305: Tax types and categories will differ from country to country. They are to be defined by national guidelines.

Example: TAX+7+VAT:23:6:21+1234:23:6+A+A:23:6:12.5:1:23:6+S+123'

Example: TAX+7+VAT+++:::21+S'

Max. Occ. = Maximum Occurrence, St = Status, * = Restricted Codes

Status: M=Mandatory, R=Required, O=Optional, C=Conditional, D=Dependent, A=Advised, N=Not used

Segment Layout

No. Seg	St	Max. Occ.				
SG26	C	9999999	LIN-PIA-IMD-MEA-QTY-ALI-DTM-GIN-QVR-FTX-SG27-SG28-SG29-SG30-SG31-SG33-SG34-SG35-SG39-SG45-SG47			
A group of segments providing details of the individual invoiced items. There must be at least one occurrence of Segment group 26 within an invoice, but not necessarily in a credit note or a debit note. This Segment group may be repeated to give sub-line details.						
SG34	C	99	TAX-MOA			
A group of segments specifying tax related information for the line item.						
68	MOA	C	2	Monetary amount		
To specify a monetary amount.						
Business Term	DE	EDIFACT	Format	St	*	Description
	C516	Monetary amount		M		
	5025	Monetary amount type code qualifier	an..3	M		124 Tax amount 125 Taxable amount
	5004	Monetary amount	n..35	R		
This segment is used to specify in monetary terms the amount of tax due on the current line item. Example: 21% (expressed in TAX segment) of 580 (expressed in MOA (SG27) segment) = 121.80. Example: MOA+124:123.52' Example: MOA+124:121.80'						

Max. Occ. = Maximum Occurrence, St = Status, * = Restricted Codes
Status: M=Mandatory, R=Required, O=Optional, C=Conditional, D=Dependent, A=Advised, N=Not used

Segment Layout

No. Seg	St	Max. Occ.	
SG26	C	9999999	LIN-PIA-IMD-MEA-QTY-ALI-DTM-GIN-QVR-FTX-SG27-SG28-SG29-SG30-SG31-SG33-SG34-SG35-SG39-SG45-SG47
<p>A group of segments providing details of the individual invoiced items. There must be at least one occurrence of Segment group 26 within an invoice, but not necessarily in a credit note or a debit note. This Segment group may be repeated to give sub-line details.</p>			
SG35	C	99	NAD-SG36
<p>A group of segments identifying the parties with associated information, relevant to the line item only.</p>			
69	NAD	M 1	Name and address
<p>To specify the name/address and their related function, either by C082 only and/or unstructured by C058 or structured by C080 thru 3207.</p>			

Business Term	DE	EDIFACT	Format	St	*	Description
	3035	Party function code qualifier	an..3	M		BY Buyer DP Delivery party II Issuer of invoice IV Invoicee PE Payee RB Receiving financial institution SR Supplier's agent/representative SU Supplier
	C082	Party identification details		A		
	3039	Party identifier	an..35	M		GLN - Format n13
	1131	Code list identification code	an..17	O		
	3055	Code list responsible agency code	an..3	R	*	9 GS1
	C058	Name and address		O		This composite may only be used to fulfill the requirements of directive 2003/58/EC, article 4.
	3124	Name and address description	an..35	M		
	3124	Name and address description	an..35	O		
	3124	Name and address description	an..35	O		
	3124	Name and address description	an..35	O		
	3124	Name and address description	an..35	O		
	C080	Party name		D		
	3036	Party name	an..35	M		Party Name in clear text.
	3036	Party name	an..35	O		
	3036	Party name	an..35	O		
		Party name				

Max. Occ. = Maximum Occurrence, St = Status, * = Restricted Codes
 Status: M=Mandatory, R=Required, O=Optional, C=Conditional, D=Dependent, A=Advised, N=Not used

Segment Layout

Business Term	DE	EDIFACT	Format	St	*	Description
	3036		an..35	O		
	3036	Party name	an..35	O		
	3045	Party name format code	an..3	O		
	C059	Street		D		
	3042	Street and number or post office box identifier	an..35	M		Building Name/Number and Street
	3042	Street and number or post office box identifier	an..35	O		Name and/or P.O. Box
	3042	Street and number or post office box identifier	an..35	O		
	3042	Street and number or post office box identifier	an..35	O		
	3164	City name	an..35	D		City/Town, clear text.
	C819	Country sub-entity details		D		
	3229	Country sub-entity name code	an..9	O		
	1131	Code list identification code	an..17	O		
	3055	Code list responsible agency code	an..3	O		
	3228	Country sub-entity name	an..70	O		County/State, clear text.
	3251	Postal identification code	an..17	D		Postal Code
	3207	Country name code	an..3	D		ISO 3166 two alpha code

This segment is used to identify parties which are valid only for the current line item. Parties identified here override those specified in the NAD segment at heading level when the same qualifier is used.

Example:

Dependency Notes:

The following composites and data elements are only used when a coded name and address can not be used. The affected composites and data elements are as follows:

C080 - C059 - 3164 - C819 - 3251 - 3207

Example: NAD+DP+541234500013:23:9+X:::X+P:P1:P2:P3:P4:1+S:S1:S2:X+C+I:23:2:X+1+IE'

Example: NAD+DP+541234500013::9'

Segment Layout

No. Seg	St	Max. Occ.				
SG26	C	9999999	LIN-PIA-IMD-MEA-QTY-ALI-DTM-GIN-QVR-FTX-SG27-SG28-SG29-SG30-SG31-SG33-SG34-SG35-SG39-SG45-SG47			
A group of segments providing details of the individual invoiced items. There must be at least one occurrence of Segment group 26 within an invoice, but not necessarily in a credit note or a debit note. This Segment group may be repeated to give sub-line details.						
SG35	C	99	NAD-SG36			
A group of segments identifying the parties with associated information, relevant to the line item only.						
SG36	C	5	RFF			
A group of segment for giving references only relevant to the specified party rather than the whole line item.						
70	RFF	M	1	Reference		
To specify a reference.						
Business Term	DE	EDIFACT	Format	St	*	Description
	C506	Reference		M		
	1153	Reference code qualifier	an..3	M	*	AQQ Activite Principale Exercee (APE) identifier GN Government reference number VA VAT registration number XA Company/place registration number YC1 Additional party identification (GS1 Temporary Code)
	1154	Reference identifier	an..70	R		
This segment is used to specify references related to the party identified in the NAD at line level. Example: Example: RFF+YC1:DN8523' Example: RFF+VA:VR85231142'						

Max. Occ. = Maximum Occurrence, St = Status, * = Restricted Codes
Status: M=Mandatory, R=Required, O=Optional, C=Conditional, D=Dependent, A=Advised, N=Not used

Segment Layout

No. Seg	St	Max. Occ.				
SG26	C	9999999	LIN-PIA-IMD-MEA-QTY-ALI-DTM-GIN-QVR-FTX-SG27-SG28-SG29-SG30-SG31-SG33-SG34-SG35-SG39-SG45-SG47			
<p>A group of segments providing details of the individual invoiced items. There must be at least one occurrence of Segment group 26 within an invoice, but not necessarily in a credit note or a debit note. This Segment group may be repeated to give sub-line details.</p>						
SG39	C	30	ALC-ALI-DTM-SG40-SG41-SG42-SG43-SG44			
<p>A group of segments specifying allowances and charges for the line item. Allowances and charges in the heading section of a message are independent from those in the detail section, e.g. ALC at detail level does not override ALC at heading level.</p>						
71	ALC	M	1	Allowance or charge		
<p>To identify allowance or charge details.</p>						
Business Term	DE	EDIFACT	Format	St	*	Description
	5463	Allowance or charge code qualifier	an..3	M		A Allowance C Charge
	C552	Allowance/charge information		O		
	1230	Allowance or charge identifier	an..35	D		If code '69' is used in DE 5189, the agreement number must be specified in DE 1230.
	5189	Allowance or charge identification code	an..3	O		69 Charge for a customer specific finish 101 Carbon footprint charge 105 Yearly turnover
	4471	Settlement means code	an..3	O		2 Off invoice 5 Charge to be paid by vendor 6 Charge to be paid by customer
	1227	Calculation sequence code	an..3	D		1 First step of calculation 2 Second step of calculation etc, etc, etc, 9 Ninth step of calculation If the allowance or charge is not to be applied against a fixed price then the calculation sequence indicator must be included.
	C214	Special services identification		D		This composite is only included if the buyer knows the type of allowance or charge and is agreed between trading partners in their interchange agreement.

Max. Occ. = Maximum Occurrence, St = Status, * = Restricted Codes
 Status: M=Mandatory, R=Required, O=Optional, C=Conditional, D=Dependent, A=Advised, N=Not used

Segment Layout

Business Term	DE	EDIFACT	Format	St	*	Description
	7161	Special service description code	an..3	R		AEK Cash on delivery service ADS Full pallet ordering ADT Pick-up AJ Adjustments CAC Cash discount CAV Battery collection and recycling FC Freight charge QD Quantity discount X40 Allowance/charge regulated by law (GS1 Temporary Code) In case of an environmental fee which is a tax then this should be expressed in DE 5153 of the TAX segment.
	1131	Code list identification code	an..17	O		
	3055	Code list responsible agency code	an..3	D		9 GS1 Code value 9 is used when GS1 codes are used in DE 7161.
	7160	Special service description	an..35	O		
	7160	Special service description	an..35	O		
This segment is used to specify any allowances or charges which apply only to the line item being invoiced. Example: Example: ALC+A+DISC920802:69+2+1+CAC:23:6:1:1' Example: ALC+A+++1'						

Max. Occ. = Maximum Occurrence, St = Status, * = Restricted Codes
 Status: M=Mandatory, R=Required, O=Optional, C=Conditional, D=Dependent, A=Advised, N=Not used

Segment Layout

No. Seg	St	Max. Occ.				
SG26	C	9999999	LIN-PIA-IMD-MEA-QTY-ALI-DTM-GIN-QVR-FTX-SG27-SG28-SG29-SG30-SG31-SG33-SG34-SG35-SG39-SG45-SG47			
A group of segments providing details of the individual invoiced items. There must be at least one occurrence of Segment group 26 within an invoice, but not necessarily in a credit note or a debit note. This Segment group may be repeated to give sub-line details.						
SG39	C	30	ALC-ALI-DTM-SG40-SG41-SG42-SG43-SG44			
A group of segments specifying allowances and charges for the line item. Allowances and charges in the heading section of a message are independent from those in the detail section, e.g. ALC at detail level does not override ALC at heading level.						
72	ALI	C	5	Additional information		
To indicate that special conditions due to the origin, customs preference, fiscal or commercial factors are applicable.						
Business Term	DE	EDIFACT	Format	St	*	Description
	3239	Country of origin name code	an..3	O		Use ISO 3166 code
	9213	Duty regime type code	an..3	O		
	4183	Special condition code	an..3	O		6 Subject to bonus 15 Not subject to discount 116 Subject to postponed discount
	4183	Special condition code	an..3	O		
	4183	Special condition code	an..3	O		
	4183	Special condition code	an..3	O		
	4183	Special condition code	an..3	O		
This segment is used to indicate any special conditions applicable to the allowances or charges detailed at line level. Example: Example: ALI+GB+1+1+1+1+1+1 ' Example: ALI+++6'						

Max. Occ. = Maximum Occurrence, St = Status, * = Restricted Codes
Status: M=Mandatory, R=Required, O=Optional, C=Conditional, D=Dependent, A=Advised, N=Not used

Segment Layout

No. Seg	St	Max. Occ.				
SG26	C	9999999	LIN-PIA-IMD-MEA-QTY-ALI-DTM-GIN-QVR-FTX-SG27-SG28-SG29-SG30-SG31-SG33-SG34-SG35-SG39-SG45-SG47			
<p>A group of segments providing details of the individual invoiced items. There must be at least one occurrence of Segment group 26 within an invoice, but not necessarily in a credit note or a debit note. This Segment group may be repeated to give sub-line details.</p>						
SG39	C	30	ALC-ALI-DTM-SG40-SG41-SG42-SG43-SG44			
<p>A group of segments specifying allowances and charges for the line item. Allowances and charges in the heading section of a message are independent from those in the detail section, e.g. ALC at detail level does not override ALC at heading level.</p>						
73	DTM	C	5	Date/time/period		
<p>To specify date, and/or time, or period.</p>						
Business Term	DE	EDIFACT	Format	St	*	Description
	C507	Date/time/period		M		
	2005	Date or time or period function code qualifier	an..3	M	*	140 Payment due date 531 Payment period
	2380	Date or time or period value	an..35	R		
	2379	Date or time or period format code	an..3	R		102 CCYYMMDD 203 CCYYMMDDHHMM 718 CCYYMMDD- CCYYMMDD
<p>This segment is used to provide any dates or periods related to the allowances or charges of the current line item. Example: DTM+140:20020930:102' Example: DTM+140:X:2'</p>						

Max. Occ. = Maximum Occurrence, St = Status, * = Restricted Codes
 Status: M=Mandatory, R=Required, O=Optional, C=Conditional, D=Dependent, A=Advised, N=Not used

Segment Layout

No. Seg	St	Max. Occ.	
SG26	C	9999999	LIN-PIA-IMD-MEA-QTY-ALI-DTM-GIN-QVR-FTX-SG27-SG28-SG29-SG30-SG31-SG33-SG34-SG35-SG39-SG45-SG47
<p>A group of segments providing details of the individual invoiced items. There must be at least one occurrence of Segment group 26 within an invoice, but not necessarily in a credit note or a debit note. This Segment group may be repeated to give sub-line details.</p>			
SG39	C	30	ALC-ALI-DTM-SG40-SG41-SG42-SG43-SG44
<p>A group of segments specifying allowances and charges for the line item. Allowances and charges in the heading section of a message are independent from those in the detail section, e.g. ALC at detail level does not override ALC at heading level.</p>			
SG40	C	1	QTY
<p>A group of segments specifying the quantity of the allowance or charge with its measure unit specifier.</p>			
74	QTY	M 1	Quantity
<p>To specify a pertinent quantity.</p>			
Business Term	DE	EDIFACT	Format St * Description
	C186	Quantity details	M
	6063	Quantity type code qualifier	an..3 M 1 Discrete quantity
	6060	Quantity	an..35 M
	6411	Measurement unit code	an..3 D
<p>The segment is used to specify quantity discounts or charges for the line being invoiced. Example: Example: QTY+1:12:KGM ' Example: QTY+1:12 '</p>			

Max. Occ. = Maximum Occurrence, St = Status, * = Restricted Codes
 Status: M=Mandatory, R=Required, O=Optional, C=Conditional, D=Dependent, A=Advised, N=Not used

Segment Layout

No. Seg	St	Max. Occ.				
SG26	C	9999999	LIN-PIA-IMD-MEA-QTY-ALI-DTM-GIN-QVR-FTX-SG27-SG28-SG29-SG30-SG31-SG33-SG34-SG35-SG39-SG45-SG47			
<p>A group of segments providing details of the individual invoiced items. There must be at least one occurrence of Segment group 26 within an invoice, but not necessarily in a credit note or a debit note. This Segment group may be repeated to give sub-line details.</p>						
SG39	C	30	ALC-ALI-DTM-SG40-SG41-SG42-SG43-SG44			
<p>A group of segments specifying allowances and charges for the line item. Allowances and charges in the heading section of a message are independent from those in the detail section, e.g. ALC at detail level does not override ALC at heading level.</p>						
SG41	C	1	PCD			
<p>A group of segments specifying the percentage for the allowance or charge.</p>						
75	PCD	M 1	Percentage details			
<p>To specify percentage information.</p>						
Business Term	DE	EDIFACT	Format	St	*	Description
	C501	Percentage details		M		
	5245	Percentage type code qualifier	an..3	M		1 Allowance 2 Charge
	5482	Percentage	n..10	R		
	5249	Percentage basis identification code	an..3	O		
	1131	Code list identification code	an..17	O		
	3055	Code list responsible agency code	an..3	D		
<p>This segment is used to specify percentage discounts or charges for the line item being invoiced. Example: Example: PCD+1:0.75:1:23:6 ' Example: PCD+1:0.75 '</p>						

Max. Occ. = Maximum Occurrence, St = Status, * = Restricted Codes
Status: M=Mandatory, R=Required, O=Optional, C=Conditional, D=Dependent, A=Advised, N=Not used

Segment Layout

No. Seg	St	Max. Occ.				
SG26	C	9999999	LIN-PIA-IMD-MEA-QTY-ALI-DTM-GIN-QVR-FTX-SG27-SG28-SG29-SG30-SG31-SG33-SG34-SG35-SG39-SG45-SG47			
A group of segments providing details of the individual invoiced items. There must be at least one occurrence of Segment group 26 within an invoice, but not necessarily in a credit note or a debit note. This Segment group may be repeated to give sub-line details.						
SG39	C	30	ALC-ALI-DTM-SG40-SG41-SG42-SG43-SG44			
A group of segments specifying allowances and charges for the line item. Allowances and charges in the heading section of a message are independent from those in the detail section, e.g. ALC at detail level does not override ALC at heading level.						
SG42	C	2	MOA			
A group of segments specifying a monetary amount for an allowance or charge.						
76	MOA	M 1	Monetary amount			
To specify a monetary amount.						
Business Term	DE	EDIFACT	Format	St	*	Description
	C516	Monetary amount		M		
	5025	Monetary amount type code qualifier	an..3	M		23 Charge amount 25 Charge/allowance basis 204 Allowance amount
	5004	Monetary amount	n..35	R		
This segment is used to specify monetary allowances/charges for the line item being invoiced. Example: Example: MOA+8:12.20' Example: MOA+204:12.20'						

Max. Occ. = Maximum Occurrence, St = Status, * = Restricted Codes
Status: M=Mandatory, R=Required, O=Optional, C=Conditional, D=Dependent, A=Advised, N=Not used

Segment Layout

No. Seg	St	Max. Occ.				
SG26	C	9999999	LIN-PIA-IMD-MEA-QTY-ALI-DTM-GIN-QVR-FTX-SG27-SG28-SG29-SG30-SG31-SG33-SG34-SG35-SG39-SG45-SG47			
<p>A group of segments providing details of the individual invoiced items. There must be at least one occurrence of Segment group 26 within an invoice, but not necessarily in a credit note or a debit note. This Segment group may be repeated to give sub-line details.</p>						
SG39	C	30	ALC-ALI-DTM-SG40-SG41-SG42-SG43-SG44			
<p>A group of segments specifying allowances and charges for the line item. Allowances and charges in the heading section of a message are independent from those in the detail section, e.g. ALC at detail level does not override ALC at heading level.</p>						
SG43	C	1	RTE			
<p>A group of segments specifying the rate per unit and basis to which the allowance or charge applies, e.g. The allowance/charge amount is 3 EUR per 10 tons.</p>						
77	RTE	M	1	Rate details		
<p>To specify rate information.</p>						
Business Term	DE	EDIFACT	Format	St	*	Description
	C128	Rate details		M		
	5419	Rate type code qualifier	an..3	M		1 Allowance rate 2 Charge rate
	5420	Unit price basis rate	n..15	M		
	5284	Unit price basis value	n..9	O		
	6411	Measurement unit code	an..3	O		
<p>This segment is used to specify allowance or charge rates for the line item being invoiced. Example: Example: RTE+1:1.25:1:KWT ' Example: RTE+1:1.25 '</p>						

Max. Occ. = Maximum Occurrence, St = Status, * = Restricted Codes
 Status: M=Mandatory, R=Required, O=Optional, C=Conditional, D=Dependent, A=Advised, N=Not used

Segment Layout

No. Seg	St	Max. Occ.	
SG26	C	9999999	LIN-PIA-IMD-MEA-QTY-ALI-DTM-GIN-QVR-FTX-SG27-SG28-SG29-SG30-SG31-SG33-SG34-SG35-SG39-SG45-SG47
<p>A group of segments providing details of the individual invoiced items. There must be at least one occurrence of Segment group 26 within an invoice, but not necessarily in a credit note or a debit note. This Segment group may be repeated to give sub-line details.</p>			
SG39	C	30	ALC-ALI-DTM-SG40-SG41-SG42-SG43-SG44
<p>A group of segments specifying allowances and charges for the line item. Allowances and charges in the heading section of a message are independent from those in the detail section, e.g. ALC at detail level does not override ALC at heading level.</p>			
SG44	C	5	TAX-MOA
<p>A group of segments specifying tax related information for the allowance or charge.</p>			
TAX	M	1	Duty/tax/fee details
<p>To specify relevant duty/tax/fee information.</p>			

78

Business Term	DE	EDIFACT	Format	St	*	Description
	5283	Duty or tax or fee function code qualifier	an..3	M		5 Customs duty 7 Tax
	C241	Duty/tax/fee type		D		
	5153	Duty or tax or fee type name code	an..3	O		GST Goods and services tax VAT Value added tax
	1131	Code list identification code	an..17	O		
	3055	Code list responsible agency code	an..3	D		
	5152	Duty or tax or fee type name	an..35	O		
	C533	Duty/tax/fee account detail		O		
	5289	Duty or tax or fee account code	an..6	M		
	1131	Code list identification code	an..17	O		
	3055	Code list responsible agency code	an..3	D		
	5286	Duty or tax or fee assessment basis value	an..15	O		
	C243	Duty/tax/fee detail		A		
	5279	Duty or tax or fee rate code	an..7	O		
	1131	Code list identification code	an..17	O		
	3055	Code list responsible agency code	an..3	D		
	5278	Duty or tax or fee rate	an..17	R		The actual rate of tax/duty.
	5273	Duty or tax or fee rate basis code	an..12	O		
		Code list identification				

Max. Occ. = Maximum Occurrence, St = Status, * = Restricted Codes
 Status: M=Mandatory, R=Required, O=Optional, C=Conditional, D=Dependent, A=Advised, N=Not used

Segment Layout

Business Term	DE	EDIFACT	Format	St	*	Description
	1131	code	an..17	O		
	3055	Code list responsible agency code	an..3	D		
	5305	Duty or tax or fee category code	an..3	D		A Mixed tax rate E Exempt from tax S Standard rate
	3446	Party tax identifier	an..20	O		

This segment is used to identify any taxes or duties which apply to the allowances or charges at LIN level.

Example:

Dependency Notes:

DE C241 and 5305: Tax types and categories will differ from country to country. They are to be defined by national guidelines.

Example: TAX+7+VAT:23:6:1+1:23:6+1+1:23:6:12.5:1:23:6+S+2 '

Example: TAX+7+VAT+++:::21+S '

Max. Occ. = Maximum Occurrence, St = Status, * = Restricted Codes

Status: M=Mandatory, R=Required, O=Optional, C=Conditional, D=Dependent, A=Advised, N=Not used

Segment Layout

No. Seg	St	Max. Occ.				
SG26	C	9999999	LIN-PIA-IMD-MEA-QTY-ALI-DTM-GIN-QVR-FTX-SG27-SG28-SG29-SG30-SG31-SG33-SG34-SG35-SG39-SG45-SG47			
A group of segments providing details of the individual invoiced items. There must be at least one occurrence of Segment group 26 within an invoice, but not necessarily in a credit note or a debit note. This Segment group may be repeated to give sub-line details.						
SG39	C	30	ALC-ALI-DTM-SG40-SG41-SG42-SG43-SG44			
A group of segments specifying allowances and charges for the line item. Allowances and charges in the heading section of a message are independent from those in the detail section, e.g. ALC at detail level does not override ALC at heading level.						
SG44	C	5	TAX-MOA			
A group of segments specifying tax related information for the allowance or charge.						
79	MOA	C	2	Monetary amount		
To specify a monetary amount.						
Business Term	DE	EDIFACT	Format	St	*	Description
	C516	Monetary amount		M		
	5025	Monetary amount type code qualifier	an..3	M		124 Tax amount 125 Taxable amount
	5004	Monetary amount	n..35	R		
This segment is used to specify in monetary terms the amount of tax due for the allowances and charges for the current line item. Example: Example: MOA+1:1' Example: MOA+124:21.80'						

Max. Occ. = Maximum Occurrence, St = Status, * = Restricted Codes
Status: M=Mandatory, R=Required, O=Optional, C=Conditional, D=Dependent, A=Advised, N=Not used

Segment Layout

No. Seg	St	Max. Occ.				
SG26	C	9999999	LIN-PIA-IMD-MEA-QTY-ALI-DTM-GIN-QVR-FTX-SG27-SG28-SG29-SG30-SG31-SG33-SG34-SG35-SG39-SG45-SG47			
<p>A group of segments providing details of the individual invoiced items. There must be at least one occurrence of Segment group 26 within an invoice, but not necessarily in a credit note or a debit note. This Segment group may be repeated to give sub-line details.</p>						
SG45	C	10	TDT			
<p>A group of segments identifying the mode and means of transport relating to the line item, where this is different to or not specified within the heading section.</p>						
80	TDT	M	1	Details of transport		
<p>To specify the transport details such as mode of transport, means of transport, its conveyance reference number and the identification of the means of transport.</p>						
Business Term	DE	EDIFACT	Format	St	*	Description
	8051	Transport stage code qualifier	an..3	M		20 Main-carriage transport
	8028	Means of transport journey identifier	an..17	O		Reference number covering the transport
	C220	Mode of transport		A		
	8067	Transport mode name code	an..3	R		
	C228	Transport means		O		DE 8179 and 8178 are only used when the type of transport must be specifically identified, i.e. where a generic description such as road transport is unsuitable.
	8179	Transport means description code	an..8	D		23 Rail bulk car 31 Truck
	8178	Transport means description	an..17	D		
	C040	Carrier		O		
	3127	Carrier identifier	an..17	A		Global Location Number GLN - Format n13
	1131	Code list identification code	an..17	O		
	3055	Code list responsible agency code	an..3	D		9 GS1 DE 3055 must be used if DE 3127 is used.
	3128	Carrier name	an..35	O		
	8101	Transit direction indicator code	an..3	O		BS Buyer to supplier SB Supplier to buyer
	C401	Excess transportation information		N		
	8457	Excess transportation reason code	an..3			
	C222	Transport identification		O		
	8213	Transport means	an..9	O		

Max. Occ. = Maximum Occurrence, St = Status, * = Restricted Codes
 Status: M=Mandatory, R=Required, O=Optional, C=Conditional, D=Dependent, A=Advised, N=Not used

Segment Layout

Business Term	DE	EDIFACT	Format	St	*	Description
		identification name identifier				
	1131	Code list identification code	an..17	O		
	3055	Code list responsible agency code	an..3	D		DE 3055 must be used if DE 8213 is used.
	8212	Transport means identification name	an..35	R		Vehicle license plate/Aircraft Number
	8453	Transport means nationality code	an..3	O		ISO 3166 two alpha code

This segment is used to specify the transport means used for the product being invoiced. This segment is only used if the transport means differ from those specified in the message header.
Example:

Example: TDT+1+1+0+1:1+1:23:9:1+BS++1:23:9:1:IE'

Example: TDT+20++30+31'

Max. Occ. = Maximum Occurrence, St = Status, * = Restricted Codes

Status: M=Mandatory, R=Required, O=Optional, C=Conditional, D=Dependent, A=Advised, N=Not used

Segment Layout

No. Seg	St	Max. Occ.				
SG26	C	9999999	LIN-PIA-IMD-MEA-QTY-ALI-DTM-GIN-QVR-FTX-SG27-SG28-SG29-SG30-SG31-SG33-SG34-SG35-SG39-SG45-SG47			
A group of segments providing details of the individual invoiced items. There must be at least one occurrence of Segment group 26 within an invoice, but not necessarily in a credit note or a debit note. This Segment group may be repeated to give sub-line details.						
SG47	C	5	TOD-LOC			
A group of segments indicating the terms of delivery for the line item where this is different to or not specified within the heading section.						
81	TOD	M 1	Terms of delivery or transport			
To specify terms of delivery or transport.						
Business Term	DE	EDIFACT	Format	St	*	Description
	4055	Delivery or transport terms function code	an..3	R		3 Price and despatch condition 6 Delivery condition
	4215	Transport charges payment method code	an..3	O		DF Defined by buyer and supplier PC Prepaid but charged to customer
	C100	Terms of delivery or transport		A		
	4053	Delivery or transport terms description code	an..3	R		INCOTERMS (See EANCOM Codes Set) If INCOTERMS are applicable, then DE 3055 has to contain code value "9" and DE 1131 must be used.
	1131	Code list identification code	an..17	D		
	3055	Code list responsible agency code	an..3	D		
	4052	Delivery or transport terms description	an..70	O		
	4052	Delivery or transport terms description	an..70	O		
<p>This segment is used to specify the terms of delivery for the current line item.</p> <p>Example: Dependency Notes: Data elements 1131 and 3055 are only used if specific terms of delivery codes, which are outside those recommended by EDIFACT, are being used.</p> <p>Example: TOD+3+DF+01E:23:2:A:A' Example: TOD+3++CIF:2E:9'</p>						

Max. Occ. = Maximum Occurrence, St = Status, * = Restricted Codes
Status: M=Mandatory, R=Required, O=Optional, C=Conditional, D=Dependent, A=Advised, N=Not used

Segment Layout

No. Seg	St	Max. Occ.				
SG26	C	9999999	LIN-PIA-IMD-MEA-QTY-ALI-DTM-GIN-QVR-FTX-SG27-SG28-SG29-SG30-SG31-SG33-SG34-SG35-SG39-SG45-SG47			
A group of segments providing details of the individual invoiced items. There must be at least one occurrence of Segment group 26 within an invoice, but not necessarily in a credit note or a debit note. This Segment group may be repeated to give sub-line details.						
SG47	C	5	TOD-LOC			
A group of segments indicating the terms of delivery for the line item where this is different to or not specified within the heading section.						
82	LOC	C	2	Place/location identification		
To identify a place or a location and/or related locations.						
Business Term	DE	EDIFACT	Format	St	*	Description
	3227	Location function code qualifier	an..3	M		1 Place of terms of delivery 5 Place of departure 7 Place of delivery
	C517	Location identification		A		
	3225	Location name code	an..25	A		UN/LOCODE
	1131	Code list identification code	an..17	O		
	3055	Code list responsible agency code	an..3	D		3 IATA (International Air Transport Association) DE 3055 must be used if DE 3225 is used and does not contain an UN/LOCODE.
	3224	Location name	an..25	O		
This segment is used to identify the location where the terms of delivery apply. Example: Example: LOC+1+A:23:3:A' Example: LOC+1+BE-BRU'						

Max. Occ. = Maximum Occurrence, St = Status, * = Restricted Codes
Status: M=Mandatory, R=Required, O=Optional, C=Conditional, D=Dependent, A=Advised, N=Not used

Segment Layout

No. Seg	St	Max. Occ.				
83	UNS	M 1	Section control			
To separate header, detail and summary sections of a message.						
Notes:						
1. To be used by message designers when required to avoid ambiguities. Mandatory only if specified for the type of message concerned.						
Business Term	DE	EDIFACT	Format	St	*	Description
	0081	Section identification	a1	M		S Detail/summary section separation
This segment is used to identify the break between the message detail and message trailer sections.						
Example:						
Example: UNS+S '						
Example: UNS+S '						

Max. Occ. = Maximum Occurrence, St = Status, * = Restricted Codes

Status: M=Mandatory, R=Required, O=Optional, C=Conditional, D=Dependent, A=Advised, N=Not used

Segment Layout

No.	Seg	St	Max. Occ.			
84	CNT	C	10	Control total To provide control total.		
Business Term	DE	EDIFACT	Format	St	*	Description
	C270	Control		M		
	6069	Control total type code qualifier	an..3	M	*	1 Total value of the quantity segments at line level in a message 2 Number of line items in message 7 Total gross weight 11 Total number of packages 15 Total consignment, cube 26 Total gross measurement/ cube
	6066	Control total value	n..18	M		
	6411	Measurement unit code	an..3	O		
This segment is used to provide message control information for checking on the message receiver's in-house system. Example: Example: CNT+1:120:ACR' Example: CNT+2:120'						

Max. Occ. = Maximum Occurrence, St = Status, * = Restricted Codes
 Status: M=Mandatory, R=Required, O=Optional, C=Conditional, D=Dependent, A=Advised, N=Not used

Segment Layout

No. Seg	St	Max. Occ.				
SG50	M	100	MOA-SG51			
A group of segments giving total amounts for the whole invoice and - if relevant -detailing amounts pre-paid with relevant references.						
85	MOA	M	1	Monetary amount		
To specify a monetary amount.						
Business Term	DE	EDIFACT	Format	St	*	Description
	C516	Monetary amount		M		
	5025	Monetary amount type code qualifier	an..3	M		9 Amount due/amount payable 53 Discount amount due 79 Total line items amount 86 Message total monetary amount 113 Prepaid amount 125 Taxable amount 129 Total amount subject to payment discount 131 Total charges/allowances 165 Adjustment amount 176 Message total duty/tax/fee amount 396 Total price subsidy value 402 Total retail value 507 Net-progress payment amount 528 Calculation basis excluding all taxes
	5004	Monetary amount	n..35	R		
	6345	Currency identification code	an..3	O		
	6343	Currency type code qualifier	an..3	O		13 Recipient local currency 15 Sender local currency
This segment is used to detail prepaid amounts, or total monetary values due for the entire invoice. Example: Example: MOA+9:12563.20:AED:1' Example: MOA+86:45612.20'						

Max. Occ. = Maximum Occurrence, St = Status, * = Restricted Codes
 Status: M=Mandatory, R=Required, O=Optional, C=Conditional, D=Dependent, A=Advised, N=Not used

Segment Layout

No. Seg	St	Max. Occ.				
SG50	M	100	MOA-SG51			
A group of segments giving total amounts for the whole invoice and - if relevant -detailing amounts pre-paid with relevant references.						
SG51	C	10	RFF-DTM			
A group of segments for giving references and where necessary, their dates, relating e.g. amounts prepaid number.						
86	RFF	M	1	Reference		
To specify a reference.						
Business Term	DE	EDIFACT	Format	St	*	Description
	C506	Reference		M		
	1153	Reference code qualifier	an..3	M		PQ Payment reference
	1154	Reference identifier	an..70	R		
This segment is used to specify any references related to the message totals information. Example: Example: RFF+PQ:1' Example: RFF+PQ:4452'						

Max. Occ. = Maximum Occurrence, St = Status, * = Restricted Codes
Status: M=Mandatory, R=Required, O=Optional, C=Conditional, D=Dependent, A=Advised, N=Not used

Segment Layout

No.	Seg	St	Max. Occ.	
	SG50	M	100	MOA-SG51
	A group of segments giving total amounts for the whole invoice and - if relevant -detailing amounts pre-paid with relevant references.			
	SG51	C	10	RFF-DTM
	A group of segments for giving references and where necessary, their dates, relating e.g. amounts prepaid number.			
87	DTM	C	5	Date/time/period
	To specify date, and/or time, or period.			

Business Term	DE	EDIFACT	Format	St	*	Description
	C507	Date/time/period		M		
	2005	Date or time or period function code qualifier	an..3	M	*	171 Reference date/ time
	2380	Date or time or period value	an..35	R		
	2379	Date or time or period format code	an..3	R		102 CCYYMMDD

This segment is used to provide any dates related to the references specified in the previous RFF segment.

Example:

Example: DTM+171:19930806:102'

Example: DTM+171:20020802:102'

Max. Occ. = Maximum Occurrence, St = Status, * = Restricted Codes

Status: M=Mandatory, R=Required, O=Optional, C=Conditional, D=Dependent, A=Advised, N=Not used

Segment Layout

No. Seg	St	Max. Occ.				
SG52	C	10	TAX-MOA			
A group of segments specifying taxes totals for the invoice.						
88	TAX	M	1	Duty/tax/fee details		
To specify relevant duty/tax/fee information.						
Business Term	DE	EDIFACT	Format	St	*	Description
	5283	Duty or tax or fee function code qualifier	an..3	M		5 Customs duty 7 Tax
	C241	Duty/tax/fee type		D		
	5153	Duty or tax or fee type name code	an..3	O		GST Goods and services tax VAT Value added tax
	1131	Code list identification code	an..17	O		
	3055	Code list responsible agency code	an..3	D		
	5152	Duty or tax or fee type name	an..35	O		
	C533	Duty/tax/fee account detail		O		
	5289	Duty or tax or fee account code	an..6	M		
	1131	Code list identification code	an..17	O		
	3055	Code list responsible agency code	an..3	D		
	5286	Duty or tax or fee assessment basis value	an..15	O		
	C243	Duty/tax/fee detail		A		
	5279	Duty or tax or fee rate code	an..7	O		
	1131	Code list identification code	an..17	O		
	3055	Code list responsible agency code	an..3	D		
	5278	Duty or tax or fee rate	an..17	R		The actual rate of tax/duty.
	5273	Duty or tax or fee rate basis code	an..12	O		
	1131	Code list identification code	an..17	O		
	3055	Code list responsible agency code	an..3	D		
	5305	Duty or tax or fee category code	an..3	D		A Mixed tax rate E Exempt from tax S Standard rate
	3446	Party tax identifier	an..20	O		
This segment is used to specify the total taxes or duties due on the complete invoice.						
Example:						
Three repeats of the segment indicates that there are three standard rates of VAT included in the						

Max. Occ. = Maximum Occurrence, St = Status, * = Restricted Codes
 Status: M=Mandatory, R=Required, O=Optional, C=Conditional, D=Dependent, A=Advised, N=Not used

Segment Layout

invoice.

Dependency Notes:

DE C241 and 5305: Tax types and categories will differ from country to country. They are to be defined by national guidelines.

Example: TAX+7+VAT:23:6:1+1:23:6+1+1:23:6:12.5:1:23:6+S+1'

Example: TAX+7+VAT+++:::21+S'

Example: TAX+7+VAT+++:::12.5+S'

Example: TAX+7+VAT+++:::15+S'

Segment Layout

No. Seg	St	Max. Occ.				
SG52	C	10	TAX-MOA			
A group of segments specifying taxes totals for the invoice.						
89	MOA	C	9	Monetary amount		
To specify a monetary amount.						
Business Term	DE	EDIFACT	Format	St	*	Description
	C516	Monetary amount		M		
	5025	Monetary amount type code qualifier	an..3	M	*	77 Invoice amount 79 Total line items amount 165 Adjustment amount 124 Tax amount 125 Taxable amount 176 Message total duty/tax/fee amount 369 Goods and services tax
	5004	Monetary amount	n..35	R		
	6345	Currency identification code	an..3	N		
	6343	Currency type code qualifier	an..3	O	*	18 Tax currency
<p>This segment is used to specify the tax amounts due, for the tax rate specified in the TAX segment, covering the whole invoice. Example: Example: MOA+176:15243.32::18' Example: MOA+176:15243.32'</p>						

Max. Occ. = Maximum Occurrence, St = Status, * = Restricted Codes
 Status: M=Mandatory, R=Required, O=Optional, C=Conditional, D=Dependent, A=Advised, N=Not used

Segment Layout

No.	Seg	St	Max. Occ.			
90	SG53	C	15	ALC-ALI-MOA		
	A group of segments specifying allowances and charges summary totals for the invoice.					
	ALC	M	1	Allowance or charge		
	To identify allowance or charge details.					
Business Term	DE	EDIFACT	Format	St	*	Description
	5463	Allowance or charge code qualifier	an..3	M		A Allowance C Charge
	C552	Allowance/charge information		O		
	1230	Allowance or charge identifier	an..35	D		If code '69' is used in DE 5189, the agreement number must be specified in DE 1230.
	5189	Allowance or charge identification code	an..3	O		69 Charge for a customer specific finish
	4471	Settlement means code	an..3	O		
	1227	Calculation sequence code	an..3	N		
	C214	Special services identification		D		This composite is only included if the buyer knows the type of allowance or charge.
	7161	Special service description code	an..3	O		
	1131	Code list identification code	an..17	O		
	3055	Code list responsible agency code	an..3	D		
	7160	Special service description	an..35	O		
	7160	Special service description	an..35	O		
<p>This segment is used to specify per allowance or charge type totals for each allowances and charges. Allowances and charges detailed both at the header level and on individual product lines are summarized here.</p> <p>Example:</p> <p>Example: ALC+A+21:1+1++AA:23:6:1:1'</p> <p>Example: ALC+A+21108'</p>						

Max. Occ. = Maximum Occurrence, St = Status, * = Restricted Codes
 Status: M=Mandatory, R=Required, O=Optional, C=Conditional, D=Dependent, A=Advised, N=Not used

Segment Layout

No. Seg	St	Max. Occ.			
91	SG53	C 15	ALC-ALI-MOA		
	A group of segments specifying allowances and charges summary totals for the invoice.				
	ALI	C 1	Additional information		
To indicate that special conditions due to the origin, customs preference, fiscal or commercial factors are applicable.					
Business Term	DE	EDIFACT	Format	St	* Description
	3239	Country of origin name code	an..3	O	Use ISO 3166 Code
	9213	Duty regime type code	an..3	O	
	4183	Special condition code	an..3	O	6 Subject to bonus 15 Not subject to discount
	4183	Special condition code	an..3	O	
	4183	Special condition code	an..3	O	
	4183	Special condition code	an..3	O	
	4183	Special condition code	an..3	O	
<p>This segment is used to indicate any special conditions applicable to the allowances or charges at summary level. Example: Example: ALI+GB+1+1+1+1+1+1 ' Example: ALI+++6'</p>					

Max. Occ. = Maximum Occurrence, St = Status, * = Restricted Codes
 Status: M=Mandatory, R=Required, O=Optional, C=Conditional, D=Dependent, A=Advised, N=Not used

Segment Layout

No.	Seg	St	Max.	Occ.		
	SG53	C	15		ALC-ALI-MOA	
	A group of segments specifying allowances and charges summary totals for the invoice.					
92	MOA	C	2		Monetary amount	
	To specify a monetary amount.					
Business Term	DE	EDIFACT	Format	St	*	Description
	C516	Monetary amount		M		
	5025	Monetary amount type code qualifier	an..3	M	*	8 Allowance or charge amount 25 Charge/allowance basis 131 Total charges/allowances 400 Rebate amount
	5004	Monetary amount	n..35	R		
<p>This segment is used to specify the total monetary value per allowance or charge type. Example: Example: MOA+8:6583.49' Example: MOA+131:6583.49'</p>						

Max. Occ. = Maximum Occurrence, St = Status, * = Restricted Codes
 Status: M=Mandatory, R=Required, O=Optional, C=Conditional, D=Dependent, A=Advised, N=Not used

Segment Layout

No. Seg	St	Max. Occ.			
93	UNT	M 1	Message trailer To end and check the completeness of a message.		
Business Term	DE	EDIFACT	Format	St	* Description
	0074	Number of segments in the message	n..6	M	The total number of segments in the message is detailed here.
	0062	Message reference number	an..14	M	The message reference number detailed here should equal the one specified in the UNH segment.
<p>This segment is a mandatory UN/EDIFACT segment. It must always be the last segment in the message. Example: Example: UNT+91+1' Example: UNT+103+1'</p>					

Max. Occ. = Maximum Occurrence, St = Status, * = Restricted Codes

Status: M=Mandatory, R=Required, O=Optional, C=Conditional, D=Dependent, A=Advised, N=Not used

Segment Layout

No. Seg	St	Max. Occ.				
94	UNZ	M 1	Interchange trailer To end and check the completeness of an interchange.			
Business Term	DE	EDIFACT	Format	St	*	Description
	0036	Interchange control count	n..6	M		Number of messages or functional groups within an interchange.
	0020	Interchange control reference	an..14	M		Identical to DE 0020 in UNB segment.
<p>This segment is used to provide the trailer of an interchange. DE 0036: If functional groups are used, this is the number of functional groups within the interchange. If functional groups are not used, this is the number of messages within the interchange.</p> <p>Example: UNZ+1+12345555 ' Example: UNZ+5+12345555 '</p>						

Max. Occ. = Maximum Occurrence, St = Status, * = Restricted Codes
 Status: M=Mandatory, R=Required, O=Optional, C=Conditional, D=Dependent, A=Advised, N=Not used

Used Codes

0001	<p>Syntax identifier Coded identification of the agency controlling a syntax and syntax level used in an interchange.</p> <p>Notes: 1. a3, upper case, Controlling Agency (e.g. UNO=UN/ECE) and a1 stating level (e.g. A) (which together give UNOA).</p>
UNOA	<p>UN/ECE level A As defined in the basic code table of ISO 646 with the exceptions of lower case letters, alternative graphic character allocations and national or application-oriented graphic character allocations.</p>
UNOB	<p>UN/ECE level B As defined in the basic code table of ISO 646 with the exceptions of alternative graphic character allocations and national or application-oriented graphic character allocations.</p>
UNOC	<p>UN/ECE level C As defined in ISO/IEC 8859-1 : Information technology - Part 1: Latin alphabet No. 1.</p>
UNOD	<p>UN/ECE level D As defined in ISO/IEC 8859-2 : Information technology - Part 2: Latin alphabet No. 2.</p>
UNOE	<p>UN/ECE level E As defined in ISO/IEC 8859-5 : Information technology - Part 5: Latin/Cyrillic alphabet.</p>
UNOF	<p>UN/ECE level F As defined in ISO 8859-7 : Information processing - Part 7: Latin/Greek alphabet.</p>
0002	<p>Syntax version number Version number of the syntax identified in the syntax identifier (0001)</p> <p>Notes: 1. Increments 1 for each version.</p>
3	<p>Version 3 ISO 9735 Amendment 1:1992. GS1 Description: Syntax version number 3. This code can be used with all of the character sets (A, B, C, D, E and F).</p>

Used Codes

0007	<p>Partner identification code qualifier Qualifier referring to the source of codes for the identifiers of interchanging partners.</p> <p>Notes: 1. Used with sender/recipient identification code.</p>
14	<p>GS1 Partner identification code assigned by GS1, an international organization of GS1 Member Organizations that manages the GS1 System.</p>
0025	<p>Recipient's reference/password qualifier Qualifier for the recipient's reference or password.</p> <p>Notes: 1. If specified in IA.</p>
AA	<p>Reference Recipient's reference/password is a reference.</p>
BB	<p>Password Recipient's reference/password is a password.</p>
0029	<p>Processing priority code Code determined by the sender requesting processing priority for the interchange.</p> <p>Notes: 1. Used if specified in IA.</p>
A	<p>Highest priority Requested processing priority is the highest.</p>
0031	<p>Acknowledgement request Code determined by the sender for acknowledgement of the interchange.</p> <p>Notes: 1. Set = 1 if sender requests acknowledgement, i.e. UNB and UNZ segments received and identified.</p>
1	<p>Requested Acknowledgement is requested.</p>
0035	<p>Test indicator Indication that the interchange is a test.</p> <p>Notes: 1. Set = 1 if the interchange is a test. Otherwise not used.</p>

Used Codes

1	Interchange is a test Indicates that the interchange is a test.
5	Interchange is a service provider test Indicates that this interchange is a test with a service provider.
0051	Controlling agency Code to identify the agency controlling the specification, maintenance and publication of the message type.
UN	UN/CEFACT United Nations Centre for Trade Facilitation and Electronic Business (UN/CEFACT). GS1 Description: UN Economic Commission for Europe (UN/ECE), Committee on the development of trade (TRADE), Working Party on facilitation of international trade procedures (WP.4).
0052	Message version number Version number of a message type. Notes: 1. If UNG/UNE is used, shall be identical in UNG and UNE. The representation of 0052 was specified as n..3 in version 1 of ISO 9735.
D	Draft version/UN/EDIFACT Directory Message approved and issued as a draft message (Valid for directories published after March 1993 and prior to March 1997). Message approved as a standard message (Valid for directories published after March 1997).
0054	Message release number Release number within the current message type version number (0052). Notes: 1. The representation of 0054 was specified as n..3 in version 1 of ISO 9735.
01B	Release 2001 - B Message approved and issued in the second 2001 release of the UNTDID (United Nations Trade Data Interchange Directory).
0057	Association assigned code A code assigned by the association responsible for the design and maintenance of the message type concerned, which further identifies the message.
EAN011	GS1 version control number (GS1 Permanent Code) Indicates that the message is an EANCOM message in version 011.

Used Codes

0065	<p>Message type Code identifying a type of message and assigned by its controlling agency.</p> <p>Notes: 1. Type of message being transmitted.</p>
INVOIC	<p>Invoice message A code to identify the invoice message. GS1 Description: Message claiming payment for goods or services supplied under conditions agreed between the seller and the buyer. The UNSM invoice message, with correct data qualification, serves also as the specification for debit note and credit note messages.</p>
0081	<p>Section identification Separates sections in a message.</p>
D	<p>Header/detail section separation To qualify the segment UNS, when separating the header from the detail section of a message.</p>
S	<p>Detail/summary section separation To qualify the segment UNS, when separating the detail from the summary section of a message.</p>
1001	<p>Document name code Code specifying the document name.</p>
67	<p>Commercial dispute Document/message issued by a party (usually the buyer) to indicate that one or more invoices or one or more credit notes are disputed for payment.</p>
82	<p>Metered services invoice Document/message claiming payment for the supply of metered services (e.g., gas, electricity, etc.) supplied to a fixed meter whose consumption is measured over a period of time.</p>
83	<p>Credit note related to financial adjustments Document message for providing credit information related to financial adjustments to the relevant party, e.g., bonuses.</p>
84	<p>Debit note related to financial adjustments Document/message for providing debit information related to financial adjustments to the relevant party.</p>
130	<p>Invoicing data sheet Document/message issued within an enterprise containing data about goods sold, to be used as the basis for the preparation of an invoice.</p>
261	<p>Self billed credit note A document which indicates that the customer is claiming credit in a self billing environment.</p>

Used Codes

262	Consolidated credit note - goods and services Credit note for goods and services that covers multiple transactions involving more than one invoice.
308	Delcredere credit note A credit note sent to the party paying on behalf of a number of buyers.
325	Proforma invoice Document/message serving as a preliminary invoice, containing - on the whole - the same information as the final invoice, but not actually claiming payment.
380	Commercial invoice Document/message claiming payment for goods or services supplied under conditions agreed between seller and buyer.
381	Credit note - goods and services Document/message for providing credit information to the relevant party.
382	Commission note Document/message in which a seller specifies the amount of commission, the percentage of the invoice amount, or some other basis for the calculation of the commission to which a sales agent is entitled.
383	Debit note - goods and services Document/message for providing debit information to the relevant party.
384	Corrected invoice Commercial invoice that includes revised information differing from an earlier submission of the same invoice.
385	Consolidated invoice Commercial invoice that covers multiple transactions involving more than one vendor. GS1 Description: Commercial invoice that covers multiple transactions involving more than one delivery.
386	Prepayment invoice An invoice to pay amounts for goods and services in advance; these amounts will be subtracted from the final invoice.
388	Tax invoice An invoice for tax purposes.
389	Self-billed invoice An invoice the invoicee is producing instead of the seller.
390	Delcredere invoice An invoice sent to the party paying for a number of buyers.
393	Factored invoice Invoice assigned to a third party for collection.

Used Codes

527	Self billed debit note A document which indicates that the customer is claiming debit in a self billing environment.
1131	Code list identification code Code identifying a user or association maintained code list. Notes: 1. The codes for this data element are provided by the code list responsible agency defined in data element 3055.
23	Clearing house automated payment Self explanatory. Notes: This code value will be removed effective with directory D.04A. GS1 Description: Banking community' automated payment clearing system.
25	Bank identification Code for identification of banks. Notes: This code value will be removed effective with directory D.04A.
106	Incoterms 1980 (4110) Code to indicate applicable Incoterm (1980 edition) under which seller undertakes to deliver merchandise to buyer (ICC). Incoterms 1990: use 4053 only. Notes: This code value will be removed effective with directory D.04A.
132	Charge Identification of a type of charge. Notes: This code value will be removed effective with directory D.04A.
154	Bank branch sorting identification Identification of a specific branch of a bank. Notes: This code value will be removed effective with directory D.04A.
157	Clearing code Identification of the responsible bank/clearing house which has cleared or is ordered to do the clearing. Notes: This code value will be removed effective with directory D.04A.

Used Codes

166	<p>Social security identification Code assigned by the authority competent to issue social security identification to identify a person.</p> <p>Notes: This code value will be removed effective with directory D.04A.</p>
174	<p>Citizen identification Self explanatory.</p> <p>Notes: This code value will be removed effective with directory D.04A.</p> <p>GS1 Description: Code issued by national authority competent to issue citizen identification to identify a person.</p>
1E	<p>Incoterms 1990 (GS1 Temporary Code) Incoterms 1990 as published by the International Chamber of Commerce (ICC).</p>
2E	<p>Incoterms 2000 (GS1 Temporary Code) Incoterms 2000 as published by the International Chamber of Commerce (ICC).</p>
3E	<p>Incoterms 2010 (GS1 Temporary Code) Incoterms 2010 as published by the International Chamber of Commerce (ICC).</p>
ADR	<p>Accord European au transport international dangereuses (GS1 Temporary Code) A European agreement concerning the international carriage of dangerous goods by road.</p>
BR	<p>Brand (GS1 Temporary Code) An identifying mark or label on the products of a particular company, or the kind or make of a commodity.</p>
CA	<p>Category (GS1 Temporary Code) A class or division in a scheme of classification.</p>
CO	<p>Colour (GS1 Temporary Code) Description of the colour required/available on the goods.</p>
FL	<p>Flavor (GS1 Temporary Code) The characteristic quality of goods.</p>
HMT	<p>Hazardous material standard text (GS1 Temporary Code) Code indicating agreed standard text on hazardous materials.</p>
LOC	<p>Location Code (GS1 Temporary Code) This is a code to indicate where the EAS tag is located on the Trade Item. Values include On outside of Trade Item, Concealed inside Trade Item, Integrated Inside Trade Item.</p>

Used Codes

OAG	Organic Claim Agency (GS1 Temporary Code) A governing body that creates and maintain standards related to organic products.
OCO	Organic Trade Item Code (GS1 Temporary Code) Used to indicate the organic status of a trade item or of one or more of its components.
OUM	Ordering unit of measure (GS1 Temporary Code) The alternate Unit of Measure of how Trade Items are ordered by the Retailer under one Unit of Measure, but sold under another Unit of Measure.
SKB	SKRS recommendation (GS1 Temporary Code) SKRS recommendation for standard clothes hanger.
SRN	Service relation number (GS1 Temporary Code) A number used to identify a database entry which records recurring services, e.g., treatment of a patient in a hospital, usage by a member of a library facilities, etc.
ST	Style (GS1 Temporary Code) Specific or characteristic design in any goods.
SUM	Selling unit of measure (GS1 Temporary Code) Describes the measurement used for selling unit of the Trade Item to the end consumer.
SZ	Size (GS1 Temporary Code) Any of a series of graded classifications of measure into which goods are divided.
SZG	Size Group (GS1 Temporary Code) A description of the variable size that is necessary to uniquely specify the size of the item in conjunction with the nonpackaged size dimension.
TYP	Type Code (GS1 Temporary Code) This is a code to indicate the type of EAS tag located on the Trade Item. Values include Acousto-Magnetic, Electro-Magnetic, Ink or dye, Microwave, Radio Frequency.
X11	Diet Allergen (GS1 Temporary Code) Indication of which dietary or allergen marks that are on the package.
X12	Environment (GS1 Temporary Code) Indication of which environmental marks (e.g. recycling schemes) that are on trade item package.
X13	Ethical (GS1 Temporary Code) Indication of which ethical trading marks that are on the package.
X14	Free Form (GS1 Temporary Code) Indication of which free-from marks that are on the package.

Used Codes

X15	Expiration date (GS1 Temporary Code) Indicates the type of expiration date marked on the packaging.
X16	Nesting Direction (GS1 Temporary Code) Depicts the arrangement of two items that nest together specifically whether they nest against each other or on top of each other.
X17	Package Marks Hygienic (GS1 Temporary Code) Indication of which hygiene markings are present in the product package
X18	Hazardous Components are Removable (GS1 Temporary Code) An indicator if any hazardous components contained within the trade item can easily be separated from the other materials to facilitate product recycling.
X19	Trade Item Has Refuse Obligations (GS1 Temporary Code) Indicates if there are special disposal obligations that apply to the trade item for example INTRASTAT.
X20	Trade Item Is Designed for Easy Disassembly (GS1 Temporary Code) Indicates that the trade item is designed for easy disassembly by recycling facilities using standard industry tools.
X21	Trade Item Is Rigid Plastic Packaging Container (GS1 Temporary Code) Indicates that a product is or is contained in a Rigid Plastic Packaging Container (RPPC) as defined by laws in the target market.
X22	Trade Item Is ROHS Compliant (GS1 Temporary Code) Indicates if the product is compliant with the European Union RoHS Directive.
X23	Trade Item Is Universal Waste (GS1 Temporary Code) Indicates if a product can be considered universal waste.
X24	Trade Item Is Consumer Upgradeable Or Maintainable (GS1 Temporary Code) Indicates if a product can be easily upgraded or have parts replaced by the consumer.
X25	Trade Item Contains Short Chain Chlorinated Paraffins (GS1 Temporary Code) Indicate if the trade item and/or its components contain paints, coatings, plastics or other materials containing short chain chlorinated paraffins (SCCPs).
X26	Trade Item Contains Pesticide (GS1 Temporary Code) Indicates if the trade item is advertised or labelled as a chemical or contains a chemical that is advertised or labelled to kill, repel or prevent the growth of any living organism.
X27	Trade Item Contains Propellant (GS1 Temporary Code) Indicates if a trade item contains a compressed gas or propellant.
X28	Trade Item Contains Polyvinyl Chloride (GS1 Temporary Code) Indicate if product contains Polyvinyl Chloride (PVC), a widely used thermoplastic polymer.

Used Codes

X29	Trade Item Chemical Is Not Intended For Human Consumption (GS1 Temporary Code) Indicates that the trade item is or contains a Liquid, Gel, Paste, Powder, or Flammable solid not intended for human consumption (ingested).
X30	ROHS Compliance Failure Material (GS1 Temporary Code) The material used in the trade item that does not comply with the ROHS Directives
X31	Packaging Terms And Condition (GS1 Temporary Code) Indicates if the packaging given in the described packaging configuration is a rented, exchangeable, against deposit or one way/not reusable.
X32	Warranty Effective Date Type (GS1 Temporary Code) The type of date associated with the warranty trade item usually expressed as an event date for the item for example date of purchase, date of manufacture or date of delivery.
X33	Warranty Type (GS1 Temporary Code) Type of warranty available for the part, e.g. labour, distance, extended service.
X35	Warranty Constraint (GS1 Temporary Code) Defines the relationship between different guarantee terms, e.g. "and", "or", "the stronger", "the weaker".
X36	Seasonal Availability End Date (GS1 Temporary Code) Indicates the end date of the trade item's seasonal availability.
X37	Seasonal Availability Start Date (GS1 Temporary Code) Indicates the start date of the trade item's seasonal availability.
X38	Season Calendar Year (GS1 Temporary Code) This element indicates the calendar year in which the trade item is seasonally available.
X39	Season Parameter (GS1 Temporary Code) Indication of the season, in which the trade item is available.
X40	Trade Item Automatic Power Down is Enabled (GS1 Temporary Code) An indicator whether a product is enabled with auto power down feature when shipped to the customer.
X41	Electrical Usage Agency Code (GS1 Temporary Code) The agency that regulates electrical usage for products within a target market.
X42	Nesting Type (GS1 Temporary Code) Depicts whether a nested item fits inside or over the other item in a nesting relationship.
X43	Display Dimension Type Code (GS1 Temporary Code) Depicts certain display scenarios used for measurement.

Used Codes

X44	<p>Manufacturer Has Take Back Program (GS1 Temporary Code)</p> <p>Indicates if the manufacturer of the trade item offers any take back programs to consumers for the product to be reused, remanufactured or recycled by the manufacturer.</p>
X45	<p>Display Resolution (GS1 Temporary Code)</p> <p>The display resolution of a television or computer display.</p>
X46	<p>Orientation Preference Sequence (GS1 Temporary Code)</p> <p>Depicts the preferred sequence of orientation used to communicate the manufacturers relative preferences of orientation.</p>
X47	<p>Orientation Type (GS1 Temporary Code)</p> <p>Depicts via code a display orientation for a trade item.</p>
X48	<p>Electrical Usage Trade Item Classification Code (GS1 Temporary Code)</p> <p>A classification code value from a product classification scheme provided to drive required information for electrical usage.</p>
X49	<p>Electrical Usage Trade Item Classification Name (GS1 Temporary Code)</p> <p>A classification name from a product classification scheme provided to drive required information for electrical usage.</p>
X50	<p>Electrical Usage SubClassification Code (GS1 Temporary Code)</p> <p>A sub-classification code value from a product classification scheme provided to drive required information for electrical usage.</p>
X51	<p>Electrical Usage SubClassification Name (GS1 Temporary Code)</p> <p>A sub-classification name provided to drive required information for electrical usage.</p>
X52	<p>Confirmation Status Code (GS1 Temporary Code)</p> <p>The CIC Confirmation Code must be of a type of code number that can be generated automatically by a computer system.</p>
X53	<p>Confirmation Status Code Description (GS1 Temporary Code)</p> <p>Provides the code description that matches up with the Code that can possibly be generated automatically by a computer system.</p>
X54	<p>Additional Confirmation Status Description (GS1 Temporary Code)</p> <p>Provides a way to communicate human entered information that may not be covered by the machine to machine codes and descriptions.</p>
X55	<p>Corrective Action (GS1 Temporary Code)</p> <p>Provides the corrective action code to fix the issue that caused the problem.</p>
X56	<p>Expected Corrective Information (GS1 Temporary Code)</p> <p>Provides the expected corrective information via a human entered information that may not be covered by the machine to machine codes.</p>
X57	<p>Electrical Usage Trade Item Classification Agency (GS1 Temporary Code)</p> <p>A classification agency or organisation whose product classification scheme is being provided to drive required information for electrical usage.</p>

Used Codes

X58	ASFIS (GS1 Permanent Code) FAO alphah-3 code list for fish species identification, commercial name & scientific name.
X59	FAO fishing areas (GS1 Permanent Code) FAO fishing areas codelist.
X60	FAO Fishing gear type (GS1 Permanent Code) FAO Fishing gear type codelist.
X61	EU fish quality (GS1 Permanent Code) EU fish quality grade code list (E, A, B, C).
X62	EU fish size (GS1 Permanent Code) EU fish standardized size code list (1, 2, 3, 4, 5 & One_Size).
X63	EU fish presentation (GS1 Permanent Code) EU fish presentation code list (3 or 5 char alpha code).
ZZZ	Mutually defined Self explanatory. Note : This code value will be removed effective with directory D.04A.
1153	Reference code qualifier Code qualifying a reference.
AAB	Proforma invoice number [1088] Reference number assigned by the seller to a Proforma Invoice.
AAC	Documentary credit number [1172] Reference number assigned by issuing bank to a Documentary credit.
AAF	Debit card number A reference number identifying a debit card.
AAG	Offer or quotation number Reference number assigned by issuing party to an offer.
AAJ	Delivery order number Reference number assigned by issuer to a delivery order.
AAK	Despatch advice number Reference number assigned by issuing party to a despatch advice.
AAL	Drawing number Reference number identifying a specific product drawing.
AAM	Waybill number Reference number assigned to a waybill, see: 1001 = 700.
AAN	Delivery schedule number Reference number assigned by buyer to a delivery schedule.

Used Codes

AAO	Consignee's shipment reference number [1362] Reference assigned by the consignee to a shipment.
AAQ	Unit load device (e.g. container) identification number [8260] Marks (letters and/or numbers) which identify a unit load device e.g. freight container.
AAS	Transport document number [1188] Reference assigned by the carrier or his agent to the transport document.
AAT	Master label number Identifies the master label number of any package type.
AAU	Despatch note number [1128] Reference number assigned by the seller to a Despatch Note.
ABD	Customs tariff number (7357) Code number of the goods in accordance with the tariff nomenclature system of classification in use where the Customs declaration is made.
ABE	Declarant's reference number Unique reference number assigned to a document or a message by the declarant for identification purposes.
ABO	Originator's reference A unique reference assigned by the originator.
ABP	Declarant's Customs identity number Reference to the party whose posted bond or security is being declared in order to accept responsibility for a goods declaration and the applicable duties and taxes.
ABQ	Importer reference number Reference number assigned by the importer to identify a particular shipment for his own purposes.
ABT	Customs declaration number [1426] Number, assigned or accepted by Customs, to identify a Goods declaration.
ACD	Additional reference number Reference number provided in addition to another given reference.
ACE	Related document number Reference number identifying a related document.
ACK	Bank reference Cross reference issued by financial institution.
ACL	Principal reference number A number that identifies the principal reference.

Used Codes

ACW	Reference number to previous message Reference number assigned to the message which was previously issued (e.g. in the case of a cancellation, the primary reference of the message to be cancelled will be quoted in this element).
ACX	Banker's acceptance Reference number for banker's acceptance issued by the accepting financial institution.
ADB	Matured certificate of deposit Reference number for certificate of deposit allocated by issuing financial institution.
ADC	Loan Reference number for loan allocated by lending financial institution.
ADD	Analysis number/test number Number given to a specific analysis or test operation.
ADE	Account number Identification number of an account.
AE	Authorization for expense (AFE) number A number that identifies an authorization for expense (AFE). GS1 Description: A number providing authorization for a party to incur an expense.
AEK	Payment order number A number that identifies a payment order.
AER	Project specification number Reference number identifying a project specification.
AES	Primary reference A number that identifies the primary reference.
AFO	Beneficiary's reference Reference of the beneficiary.
AFS	Beneficiary's bank reference Reference number of the beneficiary's bank.
AGA	Agreement to pay number A number that identifies an agreement to pay. GS1 Description: A reference number guaranteeing a payment.
AGB	Contract party reference number Reference number assigned to a party for a particular contract.
AGG	Dispute number Reference number to a dispute notice. GS1 Description: A reference number identifying a previously transmitted commercial dispute.

Used Codes

AGT	Service group identification number Identification used for a group of services.
AGW	Scheme/plan number Reference number assigned to a service scheme or plan.
AHJ	Payee's reference number Reference number of the party to be paid.
AHL	Creditor's reference number Reference number of the party to whom a debt is owed.
AHM	Debtor's reference number Reference number of the party who owes an amount of money.
AHU	Request for quote number Reference number assigned by the requestor to a request for quote.
AID	Certificate of conformity Certificate certifying the conformity to predefined definitions.
AIJ	Customer's individual transaction reference number Customer's reference number allocated by the customer to one specific transaction.
AIK	Bank's individual transaction reference number Bank's reference number allocated by the bank to one specific transaction.
AIZ	Consolidated invoice number Invoice number into which other invoices are consolidated.
AJS	Agreement number A number specifying an agreement between parties.
AJT	Standard Industry Classification (SIC) number A number specifying a standard industry classification.
AKJ	Direct debit reference Reference number assigned to the direct debit operation.
AKM	Replenishment purchase order range start number Starting number of a range of purchase order numbers assigned by the buyer to vendor's replenishment orders.
AKO	Action authorization number A reference number authorizing an action.
ALK	Consignee's invoice number The invoice number assigned by a consignee.
ALL	Message batch number A number identifying a batch of messages.

Used Codes

ALM	Previous delivery schedule number A reference number identifying a previous delivery schedule.
ALN	Physical inventory recount reference number A reference to a re-count of physically held inventory.
ALO	Receiving advice number A reference number to a receiving advice.
ALP	Returnable container reference number A reference number identifying a returnable container.
ALQ	Returns notice number A reference number to a returns notice.
ALR	Sales forecast number A reference number identifying a sales forecast.
ALS	Sales report number A reference number identifying a sales report.
ALT	Previous tax control number A reference number identifying a previous tax control number. GS1 Description: A reference number identifying a previous Tax Control (TAXCON) message number.
ALV	Registered capital reference Registered capital reference of a company.
AML	Replenishment purchase order range end number Ending number of a range of purchase order numbers assigned by the buyer to vendor's replenishment orders.
AMT	Goods and Services Tax identification number An identification number assigned to an organization collecting Goods and Services Taxes (GST).
ANJ	Authorization number A number which uniquely identifies an authorization.
ANL	Deposit reference number A reference number identifying a deposit. GS1 Description: A reference number identifying a physical deposit made to a financial account by a party through the bank branch network.
ANX	Clearing reference Reference allocated by a clearing procedure.

Used Codes

ANZ	Direct debit reference Reference of the direct debit. Notes: This code value will be removed effective with directory D.02A.
AOA	Documentary payment reference Reference of the documentary payment.
AP	Accounts receivable number Reference number assigned by accounts receivable department to the account of a specific debtor.
APF	Price/sales catalogue response reference number A reference number identifying a response to a price/sales catalogue.
APG	General purpose message reference number A reference number identifying a general purpose message. EDIFACT
APH	Invoicing data sheet reference number A reference number identifying an invoicing data sheet.
API	Inventory report reference number A reference number identifying an inventory report.
APQ	Commercial account summary reference number A reference number identifying a commercial account summary.
AQQ	Activite Principale Exercee (APE) identifier The French industry code for the main activity of a company.
AQS	Nomenclature Activity Classification Economy (NACE) identifier A European industry classification code used to identify the activity of a company.
ARZ	Stock adjustment number A number identifying a stock adjustment.
ASE	Duty free products security number A security number allocated for duty free products.
ASF	Duty free products receipt authorisation number Authorisation number allocated for the receipt of duty free products.
ASG	Party information message reference Reference identifying a party information message.
ASI	Proof of delivery reference number A reference number identifying a proof of delivery which is generated by the goods recipient.
ASJ	Supplier's credit claim reference number A reference number identifying a supplier's credit claim.

Used Codes

ASK	Picture of actual product Reference identifying the picture of an actual product.
ASL	Picture of a generic product Reference identifying a picture of a generic product.
ASO	Password Code used for authentication purposes.
ASV	Product data file number The number of a product data file.
ATB	Purchase for export Customs agreement number A number assigned by a Customs authority allowing the purchase of goods free of tax because they are to be exported immediately after the purchase. EDIFACT
AUB	Party reference The reference to a party
AUD	Collection reference A reference identifying a collection.
AUG	Importer's letter of credit reference Letter of credit reference issued by importer.
AUJ	Proposed purchase order reference number A reference number assigned to a proposed purchase order.
AUK	Application for financial support reference number Reference number assigned to an application for financial support.
AUL	Manufacturing quality agreement number Reference number of a manufacturing quality agreement.
AUQ	Customs binding ruling number Binding ruling number issued by customs.
AUR	Customs non-binding ruling number Non-binding ruling number issued by customs.
AUY	International Standard Industrial Classification (ISIC) code A code specifying an international standard industrial classification.
AUZ	Customs pre-approval ruling number Pre-approval ruling number issued by Customs.
AVB	Product characteristics directory A reference to a product characteristics directory. EDIFACT
AVD	Inventory report request number A reference to a product characteristics directory. EDIFACT

Used Codes

AVG	Slaughterhouse approval number Veterinary licence number allocated by a national authority to a Slaughterhouse. EDIFACT
AVH	Meat cutting plant approval number Veterinary licence number allocated by a national authority to a meat cutting plant. EDIFACT
AVQ	Place of packing approval number Approval Number of the place where goods are packaged. Approval number of the place where goods are packaged. In the meat sector, some additional information is required for traceability purposes: cutting party, slaughterhouse, ...
AVS	Mandate Reference Reference to a specific mandate given by the relevant party for underlying business or action.
AWB	Air waybill number Reference number assigned to an air waybill, see: 1001 = 740.
AWS	Hygienic Certificate number, national Nationally set Hygienic Certificate number, such as sanitary, epidemiologic.
AWT	Administrative Reference Code Reference number assigned by Customs to a 'shipment of excise goods'.
AWV	Phone number A sequence of digits used to call from one telephone line to another in a public telephone network.
AWW	Buyer's fund number A reference number indicating the fund number used by the buyer. GS1 Note: Replaces GS1 Temporary Code BFN.
AWX	Company trading account number A reference number identifying a company trading account. GS1 Note: Replaces GS1 Temporary Code CAN.
AWY	Reserve goods identifier A reference number identifying goods in stock which have been reserved for a party. GS1 Note: Replaces GS1 Temporary Code GRN.
AWZ	Handling and movement reference number A reference number identifying a previously transmitted cargo/goods handling and movement message. GS1 Note: Replaces GS1 Temporary Code HN.

Used Codes

AXA	<p>Instruction to despatch reference number</p> <p>A reference number identifying a previously transmitted instruction to despatch message.</p> <p>GS1 Note: Replaces GS1 Temporary Code IDR.</p>
AXB	<p>Instruction for returns number</p> <p>A reference number identifying a previously communicated instruction for return message.</p> <p>GS1 Note: Replaces GS1 Temporary Code IRN.</p>
AXC	<p>Metered services consumption report number</p> <p>A reference number identifying a previously communicated metered services consumption report.</p> <p>GS1 Note: Replaces GS1 Temporary Code MSC.</p>
AXD	<p>Order status enquiry number</p> <p>A reference number to a previously sent order status enquiry.</p> <p>GS1 Note: Replaces GS1 Temporary Code OSC.</p>
AXE	<p>Firm booking reference number</p> <p>A reference number identifying a previous firm booking.</p> <p>GS1 Note: Replaces GS1 Temporary Code PFB.</p>
AXF	<p>Product inquiry number</p> <p>A reference number identifying a previously communicated product inquiry.</p> <p>GS1 Note: Replaces GS1 Temporary Code PIE.</p>
AXG	<p>Split delivery number</p> <p>A reference number identifying a split delivery.</p> <p>GS1 Note: Replaces GS1 Temporary Code SDR.</p>
AXH	<p>Service relation number</p> <p>A reference number identifying the relationship between a service provider and a service client, e.g., treatment of a patient in a hospital, usage by a member of a library facility, etc.</p> <p>GS1 Note: Replaces GS1 Temporary Code SNR.</p>
AXI	<p>Serial shipping container code</p> <p>Reference number identifying a logisitc unit.</p> <p>GS1 Note: Replaces GS1 Temporary Code SSC.</p>
AXJ	<p>Test specification number</p> <p>A reference number identifying a test specification.</p> <p>GS1 Note: Replaces GS1 Temporary Code TS.</p>
AXK	<p>Transport status report number</p> <p>[1125] A reference number identifying a transport status report.</p> <p>GS1 Note: Replaces GS1 Temporary Code TSE.</p>
AXL	<p>Tooling contract number</p> <p>A reference number of the tooling contract.</p> <p>GS1 Note: Replaces GS1 Temporary Code XB5.</p>

Used Codes

AXM	Formula reference number A reference number of a formula. GS1 Note: Replaces GS1 Temporary Code XB6.
AXN	Pre-agreement number A reference number identifying a pre-agreement. GS1 Note: Replaces GS1 Temporary Code XB7.
AXO	Product certification number Number assigned by a governing body (or their agents) to a product which certifies compliance with a standard. GS1 Note: Replaces GS1 Temporary Code XC1.
AXP	Consignment contract number Reference number identifying a consignment contract. GS1 Note: Replaces GS1 Temporary Code XC3.
AXQ	Product specification reference number Number assigned by the issuer to his product specification. GS1 Note: Replaces GS1 Temporary Code YA1.
AXR	Payroll deduction advice reference A reference number identifying a payroll deduction advice. GS1 Note: Replaces GS1 Temporary Code YA9.
BC	Buyer's contract number Reference number assigned by buyer to a contract.
BFN	Buyer's fund number (GS1 Temporary Code) A reference number indicating the fund number used by the buyer. GS1 Note: Code marked for deletion. Use value AWW instead.
BM	Bill of lading number Reference number assigned to a bill of lading, see: 1001 = 705.
BN	Booking reference number [1016] Reference number assigned by the carrier or his agent when cargo space is reserved prior to loading.
BO	Blanket order number Reference number assigned by the order issuer to a blanket order.
BT	Batch number/lot number Reference number assigned by manufacturer to a series of similar products or goods produced under similar conditions.
CAN	Company trading account number (GS1 Temporary Code) A reference number identifying a company trading account. GS1 Note: Code marked for deletion. Use value AWX instead.
CBB	Order shipment grouping reference A reference number identifying the grouping of purchase orders into one shipment. GS1 Note: Replaces GS1 Temporary Code YB4.

Used Codes

CD	Credit note number Reference number assigned to a credit note.
CED	Debit Letter number Reference number identifying the letter of debit document. GS1 Note: Replaces GS1 Temporary Code YB8.
CFF	Animal farm licence number Veterinary licence number allocated by a national authority to an animal farm. GS1 Note: Replaces GS1 Temporary Code YC3.
CH	Customer catalogue number Number identifying a catalogue for customer's usage.
CK	Cheque number Unique number assigned to one specific cheque.
CMR	Road consignment note number Reference number assigned to a road consignment note, see: 1001 = 730.
CN	Carrier's reference number Reference number assigned by carrier to a consignment.
CNE	Consolidated reference number (GS1 Temporary Code) A number identifying a consolidated reference.
CO	Buyers order number [1022] Reference number assigned by the buyer to an order.
COF	Call off order number A number that identifies a call off order.
CR	Customer reference number Reference number assigned by the customer to a transaction.
CT	Contract number Reference number of a contract concluded between parties.
CU	Consignor's reference number [1140] Reference number assigned by a consignor to a particular shipment for his own purposes or for those of the consignee.
CZ	Cooperation contract number Number issued by a party concerned given to a contract on cooperation of two or more parties.
DDC	Direct debit contract reference (SWIFT Code) A reference number identifying a direct debit contract.
DL	Debit note number Reference number assigned by issuer to a debit note.
DM	Document number [1004] Reference number assigned to the document by the issuer.

Used Codes

DQ	Delivery note number Reference number assigned by the issuer to a delivery note.
ECN	External consolidation reference number (GS1 Temporary Code) A reference number assigned to identify an external consolidation.
EID	Economic operator identifier (EO-ID) (GS1 Temporary Code) Specify the economic operator identifier (EO-ID) number, e.g. in tobacco traceability.
ERC	External recap reference number (GS1 Temporary Code) A reference number identifying an external recap.
EX	Export licence number [1208] Reference number assigned by issuing authority to an Export Licence.
FC	Fiscal number Tax payer's number. Number assigned to individual persons as well as to corporates by a public institution; this number is different from the VAT registration number.
FF	Freight forwarder's reference number [1460] Reference number assigned to the consignment by the freight forwarder.
FI	File line identifier Number assigned by the file issuer or sender to identify a specific line.
FID	Facility identifier (F-ID) (GS1 Temporary Code) Identifies the place, for example the POS or warehouse where tobacco products are traded.
FV	File version number Number given to a version of an identified file.
FX	Foreign exchange contract number Reference number identifying a foreign exchange contract.
GC	Government contract number Number assigned to a specific government/public contract.
GN	Government reference number A number that identifies a government reference. GS1 Description: This code value should not be used to provide the tax identification number for a party (use code VA).
GRN	Goods reserve number (GS1 Temporary Code) A reference number identifying goods in stock which have been reserved for a party. GS1 Note: Code marked for deletion. Use value AWY instead.

Used Codes

HN	<p>Handling and movement reference number (GS1 Temporary Code)</p> <p>A reference number identifying a previously transmitted cargo/goods handling and movement message.</p> <p>GS1 Note: Code marked for deletion. Use value AWZ instead.</p>
HS	<p>Harmonised system number</p> <p>Number specifying the goods classification under the Harmonised Commodity Description and Coding System of the Customs Co-operation Council (CCC).</p>
HWB	<p>House waybill number</p> <p>Reference number assigned to a house waybill, see: 1001 = 703.</p>
IA	<p>Internal vendor number</p> <p>Number identifying the company-internal vending department/unit.</p>
IDR	<p>Instruction to despatch reference number (GS1 Temporary Code)</p> <p>A reference number identifying a previously transmitted instruction to despatch message.</p> <p>GS1 Note: Code marked for deletion. Use value AXA instead.</p>
IP	<p>Import licence number</p> <p>[1106] Reference number assigned by the issuing authority to an Import Licence.</p>
IRN	<p>Instruction for returns number (GS1 Temporary Code)</p> <p>A reference number identifying a previously communicated instruction for return message.</p> <p>GS1 Note: Code marked for deletion. Use value AXB instead.</p>
IT	<p>Internal customer number</p> <p>Number assigned by a seller, supplier etc. to identify a customer within his enterprise.</p>
IV	<p>Invoice number</p> <p>[1334] Reference number assigned by the seller to a Commercial Invoice.</p>
LC	<p>Letter of credit number</p> <p>Reference number identifying the letter of credit document.</p>
LI	<p>Line item reference number</p> <p>(1156) Reference number identifying a particular line in a document.</p>
MB	<p>Master bill of lading number</p> <p>Reference number assigned to a master bill of lading, see: 1001 = 704.</p>
MF	<p>Manufacturer's part number</p> <p>Reference number assigned by the manufacturer to his product or part.</p>
MG	<p>Meter unit number</p> <p>Number identifying a unique meter unit.</p>
MH	<p>Manufacturing order number</p> <p>Reference number assigned by manufacturer for a given production quantity of products.</p>

Used Codes

MR	<p>Message recipient A number that identifies the message recipient. GS1 Description: Party who receives the message.</p>
MS	<p>Message sender A number that identifies the message sender. GS1 Description: Party who sends the message.</p>
MSC	<p>Metered services consumption report (GS1 Temporary Code) A reference number identifying a previously communicated metered services consumption report. GS1 Note: Code marked for deletion. Use value AXC instead.</p>
MSS	<p>Manufacturer's material safety data sheet number A number that identifies a manufacturer's material safety data sheet.</p>
MWB	<p>Master air waybill number Reference number assigned to a master air waybill, see: 1001 = 741.</p>
ON	<p>Order number (buyer) [1022] Reference number assigned by the buyer to an order.</p>
OSE	<p>Order status enquiry (GS1 Temporary Code) A reference number to a previously sent order status enquiry. GS1 Note: Code marked for deletion. Use value AXD instead.</p>
PB	<p>Payer's financial institution account number Originated company account number (ACH transfer), check, draft or wire.</p>
PD	<p>Promotion deal number Number assigned by a vendor to a special promotion activity.</p>
PFB	<p>Firm booking reference number (GS1 Temporary Code) A reference number identifying a previous firm booking. GS1 Note: Code marked for deletion. Use value AXE instead.</p>
PIE	<p>Product inquiry number (GS1 Temporary Code) A reference number identifying a previously communicated product inquiry number. GS1 Note: Code marked for deletion. Use value AXF instead.</p>
PK	<p>Packing list number (1014) Reference number assigned to a packing list, see: 1001 = 271.</p>
PL	<p>Price list number Reference number assigned to a price list. GS1 Description: This code should be used to identify a Price/Sales Catalogue (PRICAT) message.</p>
POR	<p>Purchase order response number Reference number assigned by the seller to an order response.</p>

Used Codes

PP	Purchase order change number Reference number assigned by a buyer for a revision of a purchase order.
PQ	Payment reference Reference number assigned to a payment.
PR	Price quote number Reference number assigned by the seller to a quote.
PW	Prior purchase order number Reference number of a purchase order previously sent to the supplier.
PY	Payee's financial institution account number Receiving company account number (ACH transfer), check, draft or wire.
RA	Remittance advice number A number that identifies a remittance advice.
RAK	Rack identification (GS1 Temporary Code) Identification of a warehouse rack in the location for shipment pick-up.
RCE	Recap number (GS1 Temporary Code) A reference number identifying a recap.
RCN	Railway consignment note number Reference number assigned to a rail consignment note, see: 1001 = 720.
RF	Export reference number Reference number given to an export shipment.
SB	Sales region number A number that identifies a sales region.
SD	Sales department number A number that identifies a sales department.
SDR	Split delivery reference number (GS1 Temporary Code) A reference number identifying a split delivery. GS1 Note: Code marked for deletion. Use value AXG instead.
SE	Serial number Identification number of an item which distinguishes this specific item out of an number of identical items.
SN	Seal number [9308] Identification number on Customs or other seals affixed to containers or other transport units.
SNR	Service relation number (GS1 Temporary Code) A number used to identify a database entry which records recurring services, e.g., treatment of a patient in a hospital, usage by a member of a library facility, etc. GS1 Note: Code marked for deletion. Use value AXH instead.

Used Codes

SRN	Shipment reference number Reference number assigned to a shipment. GS1 Description: Reference number assigned by a consignor to a particular shipment for his own purposes or for those of the consignee.
SS	Seller's reference number Reference number assigned to a transaction by the seller.
SSC	Serial shipping container code (GS1 Temporary Code) Reference number identifying a serial shipping container or package. GS1 Note: Code marked for deletion. Use value AXI instead.
SZ	Specification number Number assigned by the issuer to his specification.
TAU	Aggregated level unique identifier (aUI) (GS1 Temporary Code) Reference the aggregated level unique identifier (aUI), e.g. in tobacco traceability.
TIN	Transport instruction number A reference number identifying a transport instruction. EDIFACT
TL	Tax exemption licence number Number assigned by the tax authorities to a party indicating its tax exemption authorization. This number could relate to a specified business type, a specified local area or a class of products.
TP	Test report number Reference number identifying a test report document relevant to the product.
TRB	Tribunal place registration number (GS1 Temporary Code) Registration number of a company at the tribunal place.
TS	Test specification number (GS1 Temporary Code) A reference number identifying a test specification. GS1 Note: Code marked for deletion. Use value AXJ instead.
TSE	Transport status number (GS1 Temporary Code) A reference number identifying a transport status message. GS1 Note: Code marked for deletion. Use value AXK instead.
TUU	Aggregated level unique identifier (upUI) (GS1 Temporary Code) Identifies the single pack of cigarettes issued by a central EU repository.
UC	Ultimate customer's reference number The originator's reference number as forwarded in a sequence of parties involved.

Used Codes

UCN	Unique consignment reference number (1202) Unique reference of a consignment (UCRN) used for identification purposes in documents and messages exchanged between parties in international trade. See also: Unique Identifier Code (UNIC) in UN/ECE Recommendation No. 8, March 1992.
UO	Ultimate customer's order number The originator's order number as forwarded in a sequence of parties involved.
VA	VAT registration number Unique number assigned by the relevant tax authority to identify a party for use in relation to Value Added Tax (VAT).
VN	Order number (supplier) Reference number assigned by supplier to a buyer's purchase order.
XA	Company/place registration number Company registration and place as legally required.
XA4	Account servicing bank reference (SWIFT Code) A reference number allocated by an account servicing bank.
XA5	Customer to customer reference number (SWIFT Code) A reference number exchanged between customers.
XA6	Third party reference number (SWIFT Code) A number used to identify references related to third parties.
XA8	Credit card number (SWIFT Code) A reference number identifying a credit card.
XB1	Clearing number (SWIFT Code) A reference number identifying a clearing.
XB5	Tooling contract number (GS1 Temporary Code) Number of the tooling contract. GS1 Note: Code marked for deletion. Use value AXL instead.
XB6	Formula number (GS1 Temporary Code) Number of the formula. GS1 Note: Code marked for deletion. Use value AXM instead.
XB7	Pre-agreement number (GS1 Temporary Code) Number identifying a pre-agreement. GS1 Note: Code marked for deletion. Use value AXN instead.
XC1	Product certification number (GS1 Temporary Code) Number assigned by a governing body (or their agents) to a product which certifies compliance with a standard. GS1 Note: Code marked for deletion. Use value AXO instead.
XC3	Consignment contract number (GS1 Temporary Code) Reference number identifying a consignment contract. GS1 Note: Code marked for deletion. Use value AXP instead.

Used Codes

YA1	Product specification reference number (GS1 Temporary Code) Number assigned by the issuer to his product specification. GS1 Note: Code marked for deletion. Use value AXQ instead.
YA3	Numbering per year (GS1 Temporary Code) Financial statement should be identified consecutively numbered per year.
YA6	Bank statement number (SWIFT Code) A reference number identifying a bank statement.
YA9	Payroll deduction advice reference (GS1 Temporary Code) A reference number identifying a payroll deduction advice. GS1 Note: Code marked for deletion. Use value AXR instead.
YB4	Order shipment grouping reference (GS1 Temporary Code) A reference number identifying the grouping of purchase orders into one shipment. GS1 Note: Code marked for deletion. Use value CBB instead.
YB8	Debit Letter (GS1 Temporary Code) Reference number identifying the letter of debit document. GS1 Note: Code marked for deletion. Use value CED instead.
YC1	Additional party identification (GS1 Temporary Code) Reference number to an additional party identification. This number may be the internal trading partner identification number used by a party to identify its trading parties.
YC3	Farm approval number (GS1 Temporary Code) Veterinary licence number allocated by a national authority to an animal farm.
YC6	Electrical and Electronic Equipment Producer registration number (GS1 Temporary Code) National registration number of the producers of Electrical and Electronic Equipment
YC7	Batteries and Accumulators Producer registration number (GS1 Temporary Code) National registration number of the producers of Batteries and Accumulators
ZZZ	Mutually defined reference number Number based on party agreement.
1225	Message function code Code indicating the function of the message.
1	Cancellation Message cancelling a previous transmission for a given transaction.
5	Replace Message replacing a previous message.

Used Codes

7	Duplicate The message is a duplicate of a previously generated message.
9	Original Initial transmission related to a given transaction.
31	Copy Indicates that the message is a copy of an original message that has been sent, e.g. for action or information.
43	Additional transmission Message already transmitted via another communication channel. This transmission is to provide electronically processable data only.
55	Notification only The receiver may use the notification information for analysis only.
1227	Calculation sequence code Code specifying a calculation sequence.
1	First step of calculation Code specifying the first step of a calculation.
2	Second step of calculation Code specifying the second step of a calculation.
3	Third step of calculation Code specifying the third step of a calculation.
4	Fourth step of calculation Code specifying the fourth step of a calculation.
5	Fifth step of calculation Code specifying the fifth step of a calculation.
6	Sixth step of calculation Code specifying the sixth step of a calculation.
7	Seventh step of calculation Code specifying the seventh step of a calculation.
8	Eighth step of calculation Code specifying the eighth step of a calculation.
9	Ninth step of calculation Code specifying the ninth step of a calculation.
2005	Date or time or period function code qualifier Code qualifying the function of a date, time or period.
1	Service completion date/time, actual Actual date/time on which the service was completed.

Used Codes

2	Delivery date/time, requested Date on which buyer requests goods to be delivered.
3	Invoice date/time [2376] Date when a Commercial Invoice is issued.
4	Order date/time [2010] Date when an order is issued.
7	Effective date/time Date and/or time at which specified event or document becomes effective.
8	Order received date/time Date/time when the purchase order is received by the seller.
9	Processing date/time Date/time of processing.
10	Shipment date/time, requested Date on which goods should be shipped or despatched by the supplier.
11	Despatch date and/or time (2170) Date/time on which the goods are or are expected to be despatched or shipped.
12	Terms discount due date/time Date by which payment should be made if discount terms are to apply.
13	Terms net due date Date by which payment must be made.
14	Payment date/time, deferred Date/time when instalments are due.
15	Promotion start date/time Date/time when promotion activities begin.
16	Promotion end date/time Date/time when promotion activities end.
17	Delivery date/time, estimated Date and/or time when the shipper of the goods expects delivery will take place.
18	Installation date/time/period The date/time/period of the act, or an instance of installing something or someone.
35	Delivery date/time, actual Date/time on which goods or consignment are delivered at their destination.
36	Expiry date Date of expiry of the validity of a referenced document, price information or any other referenced data element with a limited validity period.

Used Codes

37	Ship not before date/time Goods should not be shipped before given date/time.
38	Ship not later than date/time Date/time by which the goods should have been shipped.
44	Availability Date/time when received item is available.
50	Goods receipt date/time Date/time upon which the goods were received by a given party.
55	Confirmed date/time Date/time which has been confirmed.
58	Clearance date (Customs) (3080) Date on which Customs formalities necessary to allow goods to be exported, to enter home use, or to be placed under another Customs procedure has been accomplished (CCC).
59	Inbond movement authorization date Inland movement authorization date.
61	Cancel if not delivered by this date The date on which cancellation should take place, if delivery has not occurred.
63	Delivery date/time, latest Date identifying a point of time after which goods shall not or will not be delivered.
64	Delivery date/time, earliest Date identifying a point in time before which the goods shall not be delivered.
67	Delivery date/time, current schedule Delivery Date deriving from actual schedule.
69	Delivery date/time, promised for [2138] Date by which, or period within which, the merchandise should be delivered to the buyer, as agreed between the seller and the buyer (generic term).
71	Delivery date/time, requested for (after and including) Delivery is requested to happen after or on given date.
72	Delivery date/time, promised for (after and including) Delivery might take place earliest at given date.
73	Guarantee period The period for which the guarantee is or will be granted.
74	Delivery date/time, requested for (prior to and including) Delivery is requested to happen prior to or including the given date.

Used Codes

75	Delivery date/time, promised for (prior to and including) Delivery might take place latest at given date.
76	Delivery date/time, scheduled for The date/time for which delivery is scheduled.
79	Shipment date/time, promised for Shipment might happen at given date/time.
90	Report start date The date on which a report is to begin.
91	Report end date The date on which a report is to end.
94	Production/manufacture date Date on which goods are produced.
95	Bill of lading date Date as specified on the bill of lading.
99	Quotation opening date The date on which the quotation has been or may be opened.
100	Product ageing period before delivery Period of time before delivery during which the product is ageing.
102	Health problem period Period of time of health problem. GS1 Description: Period of time of exceptional health problems.
117	Delivery date/time, first First possible date/time for delivery.
119	Test completion date Date when a test has been completed.
124	Despatch note date [2218] Date when a Despatch Note is issued.
126	Contract date [2326] Date when a Contract is agreed.
128	Delivery date/time, last Date when the last delivery should be or has been accomplished.
129	Exportation date Date when imported vessel/merchandise last left the country of export for the country of import.
131	Tax point date Date on which tax is due or calculated.

Used Codes

132	Arrival date/time, estimated (2348) Date/time when carrier estimates that a means of transport should arrive at the port of discharge or place of destination.
133	Departure date/time, estimated Date/time when carrier estimates that a means of transport should depart at the place of departure.
134	Rate of exchange date/time Date/time on which the exchange rate was fixed.
136	Departure date/time [2280] Date (and time) of departure of means of transport.
137	Document/message date/time (2006) Date/time when a document/message is issued. This may include authentication.
138	Payment date [2034] Date on which an amount due is made available to the creditor, in accordance with the terms of payment.
140	Payment due date Date/time at which funds should be made available.
143	Acceptance date/time of goods [2126] Date on which the goods are taken over by the carrier at the place of acceptance (CMR 4).
147	Expiry date of export licence [2078] Date of expiry of the validity of an Export Licence.
151	Importation date Date on which goods are imported, as determined by the governing Customs administration.
152	Exportation date for textiles Date when imported textiles last left the country of origin for the country of importation.
154	Acceptance date of document The date on which a document was accepted. GS1 Description: Date on which a document was, or will be, accepted.
155	Accounting period start date The first date of an accounting period.
156	Accounting period end date The last date of an accounting period.
157	Validity start date The first date of a period for which something is valid.

Used Codes

162	Release date of supplier Date when the supplier released goods.
165	Tax period start date Date when a tax period begins.
166	Tax period end date Date when a tax period ends.
167	Charge period start date The charge period's first date.
168	Charge period end date The charge period's last date.
169	Lead time Time required between order entry till earliest goods delivery.
171	Reference date/time Date/time on which the reference was issued.
174	Advise after date/time The information must be advised after the date/time indicated.
175	Advise before date/time The information must be advised before the date/time indicated.
176	Advise completed date/time The advise has been completed at the date indicated.
177	Advise on date/time The information must be advised on the date/time indicated.
178	Arrival date/time, actual [2106] Date (and time) of arrival of means of transport.
179	Booking date/time Date at which the booking was made.
180	Closing date/time Final date for delivering cargo to a liner ship.
182	Issue date Date when a document/message has been or will be issued.
186	Departure date/time, actual (2280) Date (and time) of departure of means of transport.
189	Departure date/time, scheduled Date (and time) of scheduled departure of means of transport.
190	Transshipment date/time Date and time of the transfer of the goods from one means of transport to another.

Used Codes

191	Delivery date/time, expected Date/time on which goods are expected to be delivered.
192	Expiration date/time of customs document Date on which validity of a customs document expires.
193	Execution date The date when ordered bank initiated the transaction.
194	Start date/time Date/time on which a period starts.
195	Expiry date of import licence [2272] Date of expiry of the validity of an Import Licence.
199	Positioning date/time of goods The date and/or time the goods have to be or have been positioned.
200	Pick-up/collection date/time of cargo Date/time at which the cargo is picked up.
202	Posting date The date when an entry is posted to an account.
203	Execution date/time, requested The date/time on which the ordered bank is requested to initiate the payment order, as specified by the originator (e.g. the date of the debit).
206	End date/time Date/time on which a period (from - to) ends.
209	Value date Date on which the funds are at the disposal of the beneficiary or cease to be at the disposal of the ordering customer.
211	360/30 Calculation is based on year of 360 days, month of 30 days.
212	360/28-31 Calculation is based on year of 360 days, month of 28-31 days.
213	365-6/30 Calculation is based on year of 365-6 days, month of 30 days.
214	365-6/28-31 Calculation is based on year of 365-6 days, month of 28-31 days.
215	365/28-31 Calculation is based on year of 365 days, month of 28-31 days.
216	365/30 Calculation is based on year of 365 days, month of 30 days.

Used Codes

218	Authentication/validation date/time The date/time of authentication and/or validation.
219	Crossborder date/time Date/time at which goods are transferred across a country border.
221	Interest period Number of days used for the calculation of interests.
222	Presentation date, latest Latest date for presentation of a document.
223	Delivery date/time, deferred New date and time of delivery calculated on basis of a consignee's requirement (chargeable).
227	Beneficiary's banks due date Date on which funds should be made available to the beneficiary's bank.
231	Arrival date/time, earliest Date/time of earliest arrival of means of transport.
232	Arrival date/time, scheduled Date (and time) of scheduled arrival of means of transport.
234	Collection date/time, earliest The transport order may be issued before the goods are ready for picking up. This date/time indicates from when on the carrier can have access to the consignment.
235	Collection date/time, latest In relation with the arrangements agreed between buyer and seller or between sender and main transport it may be necessary to specify the latest collection date/time.
255	Availability due date Date when ordered items should be available at a specified location.
257	Calculation date/time/period The date/time/period on which a calculation will take, or has taken, place.
260	Valuation date (Customs) Date when Customs valuation was made.
261	Release date/time Date/time assigned to identify the release of a set of rules, conditions, conventions, productions, etc.
263	Invoicing period Period for which an invoice is issued.
265	Due date The date on which some action should occur.

Used Codes

266	Validation date The date on which something was made valid, ratified or confirmed. GS1 Description: The date on which the validation of a document or message has taken place.
267	Rate/price date/time Date/time on which a rate/price is determined.
273	Validity period Dates (from/to)/period referenced documents are valid.
282	Confirmation date lead time Lead time is referenced to the date of confirmation.
306	Work period Period of execution of works.
310	Received date/time Date/time of receipt.
315	Agreement to pay date Date on which the debtor agreed to pay.
321	Promotion date/period Date/period relevant for specific promotion activities.
322	Accounting period Self-explanatory. GS1 Description: Period related to a company's accounting procedures/fiscal calendar.
324	Processing date/period Date/period a specific process happened/will happen.
325	Tax period Period a tax rate/tax amount etc. is applicable. GS1 Description: A period which is designated by tax authorities, e.g. VAT period.
326	Charge period Period a specified charge is valid for.
328	Payroll deduction date/time Date/time of a monetary deduction made from the salary of a person on a payroll.
334	Status change date/time Date/time when a status changes.
349	Packing end date Date on which packing completed.
350	Test start date Date when a test has been started.

Used Codes

351	Inspection date Date of inspection.
356	Sales date, and or time, and or period The date, and or time, and or period on which a sale took place.
357	Cancel if not published by this date Cancel if not published by this date.
358	Scheduled for delivery on or after Scheduled for delivery on or after the specified date, and or time.
359	Scheduled for delivery on or before Scheduled for delivery on or before specified date and or time.
360	Sell by date The date by which a product should be sold.
361	Best before date The best before date.
362	End availability date The end date of availability.
363	Total shelf life period A period indicating the total shelf life of a product.
364	Minimum shelf life remaining at time of despatch period Period indicating the minimum shelf life remaining for a product at the time of leaving the supplier.
365	Packaging date The date on which the packaging of a product took place.
366	Inventory report date Date on which a inventory report is made.
367	Previous meter reading date Date on which the previous reading of a meter took place.
368	Latest meter reading date Date on which the latest reading of a meter took place.
369	Date and or time of handling, estimated The date and or time when the handling action is estimated to take place.
381	Product Lifespan at time of production (GS1 Temporary Code) The total lifespan of a product at the time of its production.
382	Earliest sale date The earliest date on which the product may be made available for sale.

Used Codes

383	Cancel if not shipped by this date Cancel the order if goods not shipped by this date. GS1 Description: Cancel the identified order if it has not been shipped/despatched by this date.
417	Previous booking date/time Date/time at which the previous booking was made.
418	Minimum shelf life remaining at time of receipt The minimum shelf life remaining at the time of receipt.
419	Forecast period A period for which a forecast applies. GS1 Description: A validity period for a forecast.
423	First date of ordering The first date on which ordering may take place.
424	Last date of ordering The last date on which ordering may take place.
434	Maturity date Date at which maturity occurs.
447	Creditor's requested value date Date on which the creditor requests to be credited.
448	Referenced item creation date Creation date of referenced item.
454	Accounting value date Date against which the entry has to be legally allocated.
496	Reinstatement date Identifies the date of reinstatement.
506	Back order delivery date/time/period The date/time/period during which the delivery of a back order will take, or has taken, place.
530	Fumigation date and/or time The date/or time on which fumigation is to occur or has taken place.
531	Payment period A period of time in which a payment has been or will be made.
536	Review date Date the item was or will be reviewed.
541	First published date Date when material was first published.

Used Codes

557	Returned date Date return takes place. GS1 Description: Date by which goods must be, or have been, returned.
656	Age Length of time that a person or thing has existed. GS1 Description: Length of time that a person or animal has lived or a thing has existed.
684	Deletion date The date on which deletion occurs.
685	First sale date and/or time and/or period The first date, and/or time, and/or period a product was sold.
686	Last sale date and/or time and/or period The last date, and/or time, and/or period a product was sold.
706	File generation date and/or time Date and, or time of file generation.
743	Purchase order latest possible change date Date identifying a point of time after which a purchase order cannot be changed.
748	Open period Code identifying the period during which something is, was or will be open.
750	Before date The specified before date. EDIFACT
751	After date The specified after date. EDIFACT
753	Maturity date, optimal Date at which optimal maturity occurs. EDIFACT
754	Product ageing duration, maximum Maximum period of time during which the product is ageing. EDIFACT
755	Product ageing duration, minimum Minimum period of time during which the product is ageing. EDIFACT
758	Trade item ship date/time, earliest possible The earliest date/time that the trade item can be shipped. It indicates the earliest date that the trade item can be shipped. This is independent of any specific ship-from location.

Used Codes

759	Trade item ship date/time, latest possible The latest date/time that the trade item can be shipped. It indicates the latest date that the trade item can be shipped. This is independent of any specific ship-from location.
760	Start date/time, maximum buying quantity The date/time from which the maximum buying quantity may be purchased. The start date for when the maximum buying quantity is available to the trading partner.
761	Start date/time, minimum buying quantity The date/time from which the minimum buying quantity may be purchased. The start date for when the minimum buying quantity is available to the trading partner.
762	Marketing campaign end date/time, suggested The date and or time suggested for the marketing campaign to end. The date suggested by the supplier for the campaign to end. It indicates the end of a marketing campaign.
763	Marketing campaign start date/time, suggested The date and or time suggested for the marketing campaign to start. The date suggested by the supplier for the campaign to start. It indicates the beginning of a marketing campaign.
764	Start availability date The start date of availability. Indicates the start date of the trade item's seasonal availability.
765	Seasonal availability calendar year The calendar year of the season in which the trade item is available.
766	Goods pickup lead time Minimum time required between order entry and goods release for pick-up. Time (in weeks, days, hours ...) required between order entry and the earliest goods release (use for pick-up, not use for delivery).
767	Change date/time, latest Most recent date and/or time that the information has been changed. A system generated value identifying the date and time a record was last updated.
768	End date/time, maximum buying quantity The date and/or time until which the maximum buying quantity may be purchased. The end date for when the maximum buying quantity is no longer available to the trading partner.
769	End date/time, minimum buying quantity The date and/or time until which the minimum buying quantity may be purchased. The end date for when the minimum buying quantity is no longer available to the trading partner.

Used Codes

770	End date/time of exclusivity The date and/or time until which a product is exclusive. The Date & Time at which a product is no longer exclusive to that trading partner.
772	Handling start date and/or time, actual The actual date and/or time when the start of the handling action takes place.
773	Handling end date and/or time, estimated The date and/or time when the end of the handling action is estimated to take place.
774	Handling end date and/or time, actual The actual date and/or time when the end of the handling action takes place.
775	Minimum product lifespan for consumer The minimum life span of the product remaining after selling it to the consumer, i.e. between the "sell by date" and the "use by date" of the product.
789	Opened trade item life span The number of days the trade item that had been opened can remain on the shelf and must then be removed.
793	Reprocessing date/time Date/time on which goods previously produced are re-processed.
794	First returnable date/time The first date/time on or after which items can be returned.
795	Community visibility date/time The date/time from which information becomes visible to the target community.
796	Catch date/time Date/time of catch.
799	Validity end date The last date of a period for which something is valid. GS1 Note: Replaces GS1 Temporary Code 21E.
800	Next status report date Date of the next status report. GS1 Note: Replaces GS1 Temporary Code 40E.
801	Service connection date/time, actual The date/time on which a service was connected, e.g. telephone, water, etc. GS1 Note: Replaces GS1 Temporary Code 44E.
802	Service disconnection date/time, actual The date/time on which a service was DISconnected, e.g. telephone, water, etc. GS1 Note: Replaces GS1 Temporary Code 45E.

Used Codes

803	Empty equipment required date/time/period Date/time/period on which empty equipment is required. GS1 Note: Replaces GS1 Temporary Code 50E.
804	Product sterilisation date Date on which a product was sterilised. GS1 Note: Replaces GS1 Temporary Code 90E.
805	Stock demand cover period, expected A period of time when stocks are expected to cover demand for a product. GS1 Note: Replaces GS1 Temporary Code 96E.
806	Shipment date/time, expected Date and/or time when shipment is expected. GS1 Note: Replaces GS1 Temporary Code X13.
807	Slaughtering date/time Date/time of slaughtering
808	Animal birth date/time Date/time when an animal was born
809	Seasonal availability end date Indicates the end date of the trade item's seasonal availability
822	Delivery place booking date/time Date/time at which a booking was made at the delivery place.
823	Pickup place booking date/time Date/time at which a booking was made at the pickup place.
21E	End validity date (GS1 Temporary Code) Date indicating the end date of a validity period. GS1 Note: Code marked for deletion. Use value 799 instead.
40E	Next status date (GS1 Temporary Code) The next date on which a status report will be provided. GS1 Note: Code marked for deletion. Use value 800 instead.
41E	Product lifespan from time of production (GS1 Temporary Code) An indication of the lifespan of a product from its time of production.
44E	Connection date/time (GS1 Temporary Code) The date/time on which a service was connected, e.g. telephone, water, etc. Connection date/time
45E	Disconnection date/time (GS1 Temporary Code) The date/time on which a service was disconnected, e.g. telephone, water, etc. GS1 Note: Code marked for deletion. Use value 802 instead.
46E	Order completion date/time (GS1 Temporary Code) The date/time on which an order was completed.

Used Codes

50E	Empty equipment required date/time/period (GS1 Temporary Code) Date on which empty equipment is required. GS1 Note: Code marked for deletion. Use value 803 instead.
54E	Stuffing date/time (GS1 Temporary Code) The date/time on which the stuffing of a container is to take place, or has taken place.
55E	Un-stuffing date/time (GS1 Temporary Code) The date/time on which the un-stuffing of a container is to take place, or has taken place.
61B	Cancel if not delivered by this date unless title not published at time (GS1 Temporary Code) Cancel the product ordered if it has not been delivered by this date unless it had not been published at the time of order. GS1 Note: Code marked for deletion.
63B	Latest availability date if not yet despatched (GS1 Temporary Code) The latest availability date required for a product or order if it has not already been despatched.
90E	Product sterilisation date (GS1 Temporary Code) Date on which a product was sterilised. GS1 Note: Code marked for deletion. Use value 804 instead.
91E	First freezing date (GS1 Temporary Code) Date on which a product was first frozen.
92E	Pension deduction payment date (GS1 Temporary Code) Date when the deduction was made from the salary of the employee.
93E	Professional risk deduction payment date (GS1 Temporary Code) Date when the risk deduction was made from the salary of the employee.
94E	Health care deduction payment date (GS1 Temporary Code) Date when health care deduction was made.
96E	Stock cover period (GS1 Temporary Code) A period of time when all stocks are expected to cover demand for a product. GS1 Note: Code marked for deletion. Use value 805 instead.
98E	Discharge date/time, start (GS1 Temporary Code) Date/time when all discharge operations on the transport means have actually been started.
X13	Expect to ship by (GS1 Temporary Code) The consignment is expected to be shipped by this date and/or time. GS1 Note: Code marked for deletion. Use value 806 instead.
X14	Requested for delivery week commencing (GS1 Temporary Code) Code requesting delivery of an order or order line during a specified week.

Used Codes

X19	Material Safety Data Sheet issue date (GS1 Temporary Code) A date when a Material Safety Data Sheet has been or will be issued.
X20	Slaughter date/time (GS1 Temporary Code) Date/time of slaughtering of an animal. GS1 Note: Code marked for deletion. Use value 807 instead.
X21	Animal Birth date/time (GS1 Temporary Code) Date/time when an animal was born. For traceability purposes. GS1 Note: Code marked for deletion. Use value 808 instead.
X49	Seasonal availability end date (GS1 Temporary Code) Indicates the end date of the trade item's seasonal availability. GS1 Note: Code marked for deletion. Use value 809 instead.
X50	Committed quantity announcement date (GS1 Temporary Code) The date when quantity committed by store could be announced to the supply chain of the retailer.
XF2	Date of issue and maturity (SWIFT Code) Date when a document/message has been issued and becomes mature.
YB9	Total credits (SWIFT Code) The total value of credits to a financial account.
2009	Terms time relation code Code relating terms to a reference date, time or period.
1	Reference date Payment terms related to reference date.
2	Before reference Payment terms related to time before reference date.
3	After reference Payment terms related to time after reference date.
4	End of 10-day period containing the reference date Payment terms are at the end of the ten day period containing the reference date.
5	End of 2-week period containing the reference date Payment terms are at the end of the two week period containing the reference date.
6	End of month containing the reference date Payment terms are at the end of the month containing the reference date.
7	End of the month following the month of reference date Payment terms are at the end of the month following the month of reference date.

Used Codes

8	End of quarter containing the reference date Payment terms are at the end of the quarter containing the reference date.
9	End of year containing the reference date Payment terms are at the end of the year containing the reference date.
10	End of week containing the reference date Payment terms are at the end of the week containing the reference date.
11	End of ten day period following month after reference date's month Payment terms are 10 days after the end of the referenced month.
14	End of 15-day period containing the reference date Payment terms are at the end of the 15-day period containing the reference date.
16	Whichever is first, the 15th or last day of the month following the payment terms period The payment terms are at, whichever is first, the 15th or the last day of the month following the payment terms period (payment terms period = period of time between the reference date and the theoretical due date).
17	After end of month containing the reference date Payment terms related to a time after the end of the month containing the reference date.
2151	Period type code Code specifying the type of period.
3M	Quarter A subdivision of a year into four equal parts.
6M	Half-year A subdivision of a year into two equal parts.
CD	Calendar day (includes weekends and holidays) Period given as a number of days including weekends and holidays.
D	Day The twenty-four hour period during which the earth completes one rotation on its axis.
H	Hour One of the twenty-four sub-divisions of a day.
M	Month One of twelve divisions of the year as determined by the Gregorian calendar.
W	Week Period of seven days.

Used Codes

WD	Working days Days when the partner company normally works. GS1 Description: Days when a company normally works (excluding national holidays).
Y	Year The period of time as measured by the Gregorian calendar in which the earth completes a single revolution around the sun.
2379	Date or time or period format code Code specifying the representation of a date, time or period.
2	DDMMYY Calendar date: D = Day; M = Month; Y = Year.
101	YYMMDD Calendar date: Y = Year; M = Month; D = Day.
102	CCYYMMDD Calendar date: C = Century ; Y = Year ; M = Month ; D = Day.
104	MMWW-MMWW A period of time specified by giving the start week of a month followed by the end week of a month. Data is to be transmitted as consecutive characters without hyphen.
107	DDD Day's number within a specific year: D = Day.
108	WW Week's number within a specific year: W = Week.
109	MM Month's number within a specific year: M = Month.
110	DD Day's number within is a specific month.
201	YYMMDDHHMM Calendar date including time without seconds: Y = Year; M = Month; D = Day; H = Hour; M = Minute.
203	CCYYMMDDHHMM Calendar date including time with minutes: C=Century; Y=Year; M=Month; D=Day; H=Hour; M=Minutes.
204	CCYYMMDDHHMMSS Calendar date including time with seconds: C=Century;Y=Year; M=Month; D=Day;H=Hour;M=Minute;S=Second.
401	HHMM Time without seconds: H = Hour; m = Minute.

Used Codes

501	HHMMHHMM Time span without seconds: H = Hour; m = Minute;.
502	HHMMSS-HHMMSS Format of period to be given without hyphen.
602	CCYY Calendar year including century: C = Century; Y = Year.
609	YYMM Month within a calendar year: Y = Year; M = Month.
610	CCYYMM Month within a calendar year: CC = Century; Y = Year; M = Month.
615	YYWW Week within a calendar year: Y = Year; W = Week 1st week of January = week 01.
616	CCYYWW Week within a calendar year: CC = Century; Y = Year; W = Week (1st week of January = week 01).
713	YYMMDDHHMM-YYMMDDHHMM Format of period to be given in actual message without hyphen.
715	YYWW-YYWW A period of time specified by giving the start week of a year followed by the end week of year (both not including century). Data is to be transmitted as consecutive characters without hyphen.
717	YYMMDD-YYMMDD Format of period to be given in actual message without hyphen.
718	CCYYMMDD-CCYYMMDD Format of period to be given without hyphen.
719	CCYYMMDDHHMM-CCYYMMDDHHMM A period of time which includes the century, year, month, day, hour and minute. Format of period to be given in actual message without hyphen.
720	DHHMM-DHHMM Format of period to be given without hyphen (D=day of the week, 1=Monday; 2=Tuesday; ... 7=Sunday).
801	Year To indicate a quantity of years.
802	Month To indicate a quantity of months.
803	Week To indicate a quantity of weeks.

Used Codes

804	Day To indicate a quantity of days.
805	Hour To indicate a quantity of hours.
806	Minute To indicate a quantity of minutes.
810	Trimester To indicate a quantity of trimesters (three months).
811	Half month To indicate a quantity of half months.
21E	DDHHMM-DDHHMM (GS1 Temporary Code) Format of period to be given in actual message without hyphen.
2475	Time reference code Code referencing a point in time.
1	Date of order Payment time reference is date of order.
2	Date of confirmation Payment time reference is date of confirmation.
3	Date of contract Payment time reference is date of contract.
5	Date of invoice Payment time reference is date of invoice.
6	Date of credit note Payment time reference is date of credit note.
7	Date of present document Payment time reference is date of present document.
8	Date of confirmation of order received Payment time reference is date of confirmation received.
9	Date invoice received Payment time reference is date of invoice received.
11	Date credit note received Payment time reference is date of credit note received.
12	Date present document received Payment time reference is date of present document received.
21	Date goods received by buyer Payment time reference is date when goods are received by buyer.

Used Codes

23	Date goods received by carrier Payment time reference is date when goods are received by carrier.
26	Date of arrival of transport Date the transport arrived at the agreed destination.
27	Date of outward frontier crossing Date the goods are crossing the border of the exporters country.
28	Date of inward frontier crossing Date the goods are crossing the border of the importers country.
29	Date of delivery of goods to establishments/domicile/site Date the goods are delivered at agreed place of destination.
52	Due date of negotiable instrument Date when the negotiable instrument is due for payment.
66	Specified date Date specified elsewhere.
67	Anticipated delivery date The date on which delivery is anticipated to take place.
68	Effective date The date on which an action or event becomes effective.
69	Invoice transmission date Payment time reference is the date of invoice transmission.
70	Date of issue of transport document(s) The date on which a transport document(s) is issued.
72	Payment date Date when a payment was made.
78	Customs clearance date (import) Date when goods clear Customs in the importing country.
79	Customs clearance date (export) Date when goods clear Customs in the exporting country.
80	Date of salary payment Date when a salary payment was made.
81	Date of shipment as evidenced by the transport document(s) Date of shipment as evidenced by the transport document(s).
83	Requested date of delivery Payment terms apply from the requested date of delivery.
83E	Period of exceptional situation (GS1 Temporary Code) Period of a situation that affects the normal contribution of the employee.

Used Codes

X10	Receipt of goods (GS1 Temporary Code) Payment time reference is the date when goods are received by a receiving party.
3035	Party function code qualifier Code giving specific meaning to a party.
AB	Buyer's agent/representative Third party who arranged the purchase of merchandise on behalf of the actual buyer.
ACD	Party has access to all non publicly available data (GS1 Temporary Code) The identified party has access to all non publicly available pricing and non-pricing data associated with the current product.
ACN	Party has access only to non publicly available non-pricing data (GS1 Temporary Code) The identified party has access only to the non publicly available non-pricing data associated with the current product.
ACP	Party has access only to non publicly available pricing data (GS1 Temporary Code) The identified party has access only to the non publicly available pricing data associated with the current product.
AE	Declarant's agent/representative Any natural or legal person who makes a declaration to an official body on behalf of another natural or legal person, where legally permitted (CCC).
AG	Agent/representative (3196) Party authorized to act on behalf of another party.
AP	Accepting party (3352) Party accepting goods, products, services etc.
AS	Account servicing financial institution Identifies the financial institution servicing the account(s).
BE	Beneficiary The ultimate recipient of the funds. Normally the account owner who is reimbursed by the payor.
BF	Beneficiary's bank Identifies the account servicer for the beneficiary or the payee.
BK	Financial institution Party acting as financial institution.
BL	Bill of lading recipient Party to receive B/L.
BO	Broker or sales office Party acting in the name of the seller as broker or as sales office.

Used Codes

BQ	Cheque drawn bank Identifies the bank on which the cheque should be drawn, as instructed by the ordering customer.
BS	Bill and ship to Party receiving goods and relevant invoice.
BY	Buyer Party to whom merchandise and/or service is sold.
CA	Carrier (3126) Party undertaking or arranging transport of goods between named points.
CG	Carrier's agent Party authorized to act for or on behalf of carrier.
CH	Connecting carrier Owner or operator of a transportation conveyance to which goods in a given transaction will be transferred.
CK	Empty equipment despatch party Party from whose premises empty equipment will be or has been despatched.
CM	Customs Identification of customs authority relevant to the transaction or shipment.
CN	Consignee (3132) Party to which goods are consigned.
CO	Corporate office Identification of the Head Office within a company.
COD	Quotation requesting party The party sending the requests for quotation. GS1 Note: Replaces GS1 Temporary Code QP. EDIFACT
CPE	Central payment service (GS1 Temporary Code) Master of the conveyance. GS1 Description: A party providing central (or consolidated payment) services.
CPU	Central procurement party (GS1 Temporary Code) Party responsible for all aspects (e.g. tenders, orders, invoices, ..) of procurement.
CQ	Cheque order Party to which the cheque will be ordered, when different from the beneficiary.
CR	Empty equipment return party Party to whose premises empty equipment will be or has been returned.

Used Codes

CRB	Creditor's bank (SWIFT Code) Identifies the account servicer for the creditor.
CRE	Creditor (SWIFT Code) The party to be credited with funds.
CS	Consolidator Party consolidating various consignments, payments etc.
CW	Equipment owner Owner of equipment (container, etc.).
CX	Consignee's agent Party authorized to act on behalf of the consignee.
CZ	Consignor (3336) Party which, by contract with a carrier, consigns or sends goods with the carrier, or has them conveyed by him. Synonym: shipper, sender.
DBB	Debtor's bank (SWIFT Code) Identifies the account servicer for the debtor.
DCS	Temporary employee A person employed on a temporary basis.
DCT	Designer A party who designs.
DCU	Quotation delivered to Party to whom the quotation is to be or has been delivered. EDIFACT
DCV	Developer A party who develops.
DCX	Party to receive refund Party to whom a refund is given.
DEF	Meat cutter Person whose job is to cut up and/or mince meat. EDIFACT
DEQ	Shipper Party responsible for the shipment of goods.
DER	Source data pool A data pool that supports the functionality required by a data source such as data loading, publication, notification, registration, etc.
DES	Brand owner The owner of a brand.

Used Codes

DFZ	Article information responsible party The party responsible for article information. GS1 Note: Replaces GS1 Temporary Code IPD.
DGA	Price information responsible party The party responsible for price information. GS1 Note: Replaces GS1 Temporary Code IPR.
DGB	Invoice processing party Party to whom the invoice is sent and who processes the invoice on behalf of the invoicee. Note, the invoicee is legally responsible for the invoice and can be different to the processing party. GS1 Note: Replaces GS1 Temporary Code ITO.
DGC	Logistic service provider A party providing logistic services for another party (e.g re-packing suppliers products) on products. GS1 Note: Replaces GS1 Temporary Code LSP.
DGD	Fattener Party which provides fattening services. GS1 Note: Replaces GS1 Temporary Code X51.
DGE	Breeder Party which provides breeding. GS1 Note: Replaces GS1 Temporary Code X52.
DL	Factor Company offering a financial service whereby a firm sells or transfers title to its accounts receivable to the factoring company.
DM	Party to whom documents are to be presented Party to whom documents are to be presented.
DP	Delivery party (3144) Party to which goods should be delivered, if not identical with consignee. GS1 Description: Party to which goods should be delivered, if not the same as the buyer.
DS	Distributor Party distributing goods, financial payments or documents.
EM	Party to receive electronic memo of invoice Party being informed about invoice issue (via EDI).
EO	Owner of equipment Party who owns equipment.
EX	Exporter (3030) Party who makes - or on whose behalf a Customs clearing agent or other authorized person makes - an export declaration. This may include a manufacturer, seller or other person. Within a Customs union, consignor may have the same meaning as exporter.

Used Codes

FD	Buyer's parent company Parent company, e.g. holding company.
FP	Freight/charges payer Party responsible for the payment of freight.
FR	Message from Party where the message comes from.
FW	Freight forwarder Party arranging forwarding of goods.
GL	Socially insured person A person who is registered in a social security scheme.
GM	Inventory controller To specifically identify the party in charge of inventory control.
GO	Goods owner The party which owns the goods.
GQ	Slaughterer Party or person who has undertaken or will undertake a slaughter.
GW	Party fulfilling all operations Code indicating the fact that the party identified carries out all operations within that company's activities.
GX	Central catalogue party Party controlling a central catalogue.
GY	Inventory reporting party Party reporting inventory information.
GZ	Substitute supplier Party which may be in a position to supply products or services should the main usual supplier be unable to do so.
HP	Final message recipient To identify the final recipient of the message.
HQ	Owner of account (SWIFT Code) Identifies the owner of the account.
HX	Debtor (SWIFT Code) Party from whom payment is due.
I1	Intermediary bank 1 A financial institution between the ordered bank and the beneficiary's bank.
I2	Intermediary bank 2 A financial institution between the ordered bank and the beneficiary's bank.

Used Codes

II	Issuer of invoice (3028) Party issuing an invoice.
IM	Importer (3020) Party who makes - or on whose behalf a Customs clearing agent or other authorized person makes - an import declaration. This may include a person who has possession of the goods or to whom the goods are consigned.
IN	Insurer A person or company offering insurance policies for premiums.
IPA	Party information party (GS1 Temporary Code) The party in a company who is responsible for the party information. The PARTIN message may be requested from or sent by this party.
IPD	Article information party (GS1 Temporary Code) The party in a company who is responsible for the pricing or other article information. The PRICAT or PRODAT messages may be requested from or sent by this party. GS1 Note: Code marked for deletion. Use value DFZ instead.
IPR	Price information party (GS1 Temporary Code) The party in a company who is responsible for the price information. The PRICAT message may be requested from or sent by this party. GS1 Note: Code marked for deletion. Use value DGA instead.
ITO	Invoice recipient party (GS1 Temporary Code) Party to whom the invoice is sent and who processes the invoice on behalf of the invoicee. Note, the invoicee is legally responsible for the invoice and can be different to the processing party. GS1 Note: Code marked for deletion. Use value DGB instead.
IV	Invoicee (3006) Party to whom an invoice is issued.
JB	Goods collection party Party that will collect or has collected the goods. GS1 Description: Party that will collect or has collected the goods.
LC	Party declaring the Value Added Tax (VAT) A code to identify the party who is responsible for declaring the Value Added Tax (VAT) on the sale of goods or services.
LD	Party recovering the Value Added Tax (VAT) A code to identify the party who is eligible to recover the Value Added Tax (VAT) on the sale of goods or services.
LF	Buyer's corporate office The identification of the buyer's corporate office.
LG	Supplier's corporate office The identification of the supplier's corporate office.

Used Codes

LP	<p>Loading party</p> <p>Party responsible for the loading when other than carrier.</p>
LSP	<p>Logistic Service Provider (GS1 Temporary Code)</p> <p>A party providing logistic services for another party (e.g re-packing suppliers products) on products which may lead to added value for the product.</p> <p>GS1 Note: Code marked for deletion. Use value DGC instead.</p>
MA	<p>Party for whom item is ultimately intended</p> <p>Party for whom item is ultimately intended.</p>
MF	<p>Manufacturer of goods</p> <p>Party who manufactures the goods.</p>
MP	<p>Manufacturing plant</p> <p>Self explanatory.</p> <p>GS1 Description:</p> <p>Industrial department of a company in which goods are manufactured with appropriate equipment and fittings.</p>
MR	<p>Message recipient</p> <p>A party to receive a message or messages.</p>
MS	<p>Document/message issuer/sender</p> <p>Issuer of a document and/or sender of a message.</p>
N1	<p>Notify party no. 1</p> <p>The first party which is to be notified.</p>
N2	<p>Notify party no. 2</p> <p>The second party which is to be notified.</p>
NFP	<p>No function priority allocated (GS1 Temporary Code)</p> <p>Code indicating that the party identified is capable of carrying out all or most functions within the party.</p>
NI	<p>Notify party</p> <p>(3180) Party to be notified of arrival of goods.</p>
OB	<p>Ordered by</p> <p>Party who issued an order.</p> <p>GS1 Description:</p> <p>Party who issued an order for goods and services.</p>
OR	<p>Ordered bank</p> <p>Identifies the account servicer for the ordering customer or payor.</p>
OS	<p>Original shipper</p> <p>The original supplier of the goods.</p>
OV	<p>Owner of means of transport</p> <p>(3126) Party owning the means of transport. No synonym of carrier = CA.</p>

Used Codes

OY	Ordering customer Identifies the originator of the instruction. GS1 Description: Only used in financial messages.
P1	Contact party 1 First party to contact.
P2	Contact party 2 Second party to contact.
PB	Paying financial institution Financial institution designated to make payment.
PE	Payee Identifies the credit party when other than the beneficiary.
PF	Party to receive freight bill Party to whom the freight bill should be sent.
PL	Payor Identifies the debit party when other than the ordering customer (for banking purposes).
PO	Ordering party To be used only if ordering party and buyer are not identical.
PR	Payer (3308) Party initiating payment.
PW	Despatch party (3282) Party where goods are collected or taken over by the carrier (i.e. if other than consignor).
PX	Party to receive all documents A party which is named to be the recipient of all documents.
PY	Checking party Party or contact designated on behalf of carrier or his agent to establish the actual figures for quantities, weight, volume and/or (cube) measurements of goods or containers which are to appear in the transport contract and on which charges will be based.
RA	Central bank or regulatory authority Identifies central bank or regulatory authority which must be informed of certain aspects of a message.
RB	Receiving financial institution Financial institution designated to receive payment.
RE	Party to receive commercial invoice remittance Party to whom payment for a commercial invoice or bill should be remitted.

Used Codes

RH	Seller's financial institution Financial institution designated by seller to receive payment. RDFI (ACH transfers).
RV	Receiver of cheque Identifies the party which is to receive the actual cheque, when different from the receiver of funds.
SA	Sales person number (GS1 Temporary Code) The identification of a sales person number. GS1 Note: Code marked for deletion. Use value SE instead.
SE	Seller (3346) Party selling merchandise to a buyer. GS1 Note: Replaces GS1 Temporary Code SA.
SF	Ship from Identification of the party from where goods will be or have been shipped.
SN	Store number A party keeping a shop or store. GS1 Description: Number allocated to identify a store.
SR	Supplier's agent/representative (3254) Party representing the seller for the purpose of the trade transaction. GS1 Description: Party representing the supplier for the purpose of the trade transaction.
SS	Social securities collector's office Party collecting social securities premiums.
ST	Ship to Identification of the party to where goods will be or have been shipped.
SU	Supplier Party who supplies goods and/or services. GS1 Description: Party which provides service(s) and/or manufactures or otherwise has possession of goods, and consigns or makes them available in trade.
TC	Tax collector's office Party collecting taxes.
TPE	Testing party (GS1 Temporary Code) A party authorized to carry out a specified test.
TS	Party to receive certified test results Party to whom the certified test results should be sent.
UC	Ultimate consignee Party who has been designated on the invoice or packing list as the final recipient of the stated merchandise.

Used Codes

UD	Ultimate customer The final recipient of goods.
WH	Warehouse keeper (3022) Party taking responsibility for goods entered into a warehouse.
WS	Wholesaler Seller of articles, often in large quantities, to be retailed by others.
X47	Cash register number (GS1 Temporary Code) Number allocated to identify a cash register.
X48	Corporate identity (GS1 Temporary Code) The identity of party to whom all other parties of the same commercial organisation are linked.
X50	Mincing plant (GS1 Temporary Code) A place where the meat of animals is cut into very small pieces using a meat grinder. GS1 Note: Code marked for deletion.
X51	Fattener (GS1 Temporary Code) Party which fattens the animal. GS1 Note: Code marked for deletion. Use value DGD instead.
X52	Breeder (GS1 Temporary Code) Party which breeds the animal. GS1 Note: Code marked for deletion. Use value DGE instead.
X53	Content Owner (GS1 Temporary Code) Not available. GS1 Note: Code marked for deletion.
X54	Temperature variation (GS1 Temporary Code) Temperature variation upward or downward
X56	No / missing loading space (GS1 Temporary Code) The goods/consignment/equipment could not be loaded because of no/missing loading space.
ZZZ	Mutually defined Party specification mutually agreed between interchanging parties.
3045	Party name format code Code specifying the representation of a party name.
1	Name components in sequence as defined in description below Name component 1: Family name. Name component 2: Given name or initials. Name component 3: Given name or initials. Name component 4: Maiden name. Name component 5: Title Group of name components transmitted in sequence with name component 1 transmitted first. The maiden name is the family name given at birth of a female. Other names are self-explanatory.

Used Codes

3055	Code list responsible agency code Code specifying the agency responsible for a code list.
2	CEC (Commission of the European Communities) Generic: see also 140, 141, 142, 162. GS1 Description: Commission of the European Communities
3	IATA (International Air Transport Association) The airline industry's international organisation. GS1 Description: International Air Transport Association
5	ISO (International Organization for Standardization) International Organization of Standardization.
6	UN/ECE (United Nations - Economic Commission for Europe) United Nations Economic Commission for Europe.
7	CEFIC (Conseil Europeen des Federations de l'Industrie Chimique) EDI project for chemical industry.
8	EDIFICE Standardised electronic commerce forum for companies with interests in computing, electronics and telecommunications. GS1 Description: EDI Forum for companies with Interest in Computing and Electronics (EDI project for EDP/ADP sector).
9	GS1 GS1 (formerly EAN International), an organisation of GS1 Member Organisations, which manages the GS1 System. GS1 Description: GS1 International.
10	ODETTE Organization for Data Exchange through Tele-Transmission in Europe (European automotive industry project).
17	S.W.I.F.T. Society for Worldwide Interbank Financial Telecommunications s.c.
28	EDITEUR (European book sector electronic data interchange group) Code identifying the pan European user group for the book industry as an organisation responsible for code values in the book industry.
60	Assigned by national trade agency The code list is from a national agency.
65	GS1 France Organisation responsible for GS1 System in France.
68	GS1 Italy Organisation responsible for GS1 System in Italy.

Used Codes

83	US, National Retail Federation The National Retail Federation is the trade association for the general merchandise retailing industry. In addition to providing support and education services, they also maintain and publish standard colour and size codes for the retail industry.
84	DE, BRD (Gesetzgeber der Bundesrepublik Deutschland) German legislature.
86	Assigned by party originating the message Codes assigned by the party originating the message.
87	Assigned by carrier Codes assigned by the carrier.
88	Assigned by owner of operation Assigned by owner of operation (e.g. used in construction).
89	Assigned by distributor Codes assigned by a distributor.
90	Assigned by manufacturer Code assigned by the manufacturer.
91	Assigned by supplier or supplier's agent Codes assigned by a seller or seller's agent. GS1 Description: Code assigned by the supplier or supplier's agent.
92	Assigned by buyer or buyer's agent Codes assigned by a buyer or buyer's agent.
112	US, U.S. Census Bureau The Bureau of the Census of the U.S. Dept. of Commerce.
113	GS1 US Organisation responsible for GS1 System in the USA.
116	US, ANSI ASC X12 American National Standards Institute ASC X12.
131	DE, German Bankers Association German Bankers' Association.
136	GS1 UK Organisation responsible for GS1 System in the UK.
137	AT, Verband oesterreichischer Banken und Bankiers Austrian bankers association.
174	DE, DIN (Deutsches Institut fuer Normung) German standardization institute.

Used Codes

182	US, Standard Carrier Alpha Code (Motor) Organisation maintaining the SCAC lists and transportation operating in North America.
194	AU, AQIS (Australian Quarantine and Inspection Service) Australian Quarantine and Inspection Service.
200	GS1 Netherlands Organisation responsible for GS1 System in the Netherlands.
245	GS1 Denmark Organisation responsible for GS1 System in Denmark.
246	GS1 Germany Organisation responsible for GS1 System in Germany. GS1 Description: German representative of International Article Numbering association (GS1).
260	Ediel Nordic forum A code to identify Ediel Nordic forum, which is an organization standardizing the use of EDI between the participants in the Nordic power market.
281	GS1 Belgium & Luxembourg Organisation responsible for GS1 System in Belgium & Luxembourg.
286	SE, TCO (Tjänstemännens Central Organisation) The Swedish Confederation of Professional Employees.
294	GS1 Austria Organisation responsible for the GS1 System in Austria.
295	AU, Therapeutic Goods Administration Austrian administration responsible for the regulation of therapeutic goods in Australia. EDIFACT
297	IT, Ufficio IVA Ufficio responsabile gestione partite IVA, Italy (Italian Institute issuing VAT registration numbers). EDIFACT
298	GS1 Spain Organisation responsible for the GS1 System in Spain.
316	GS1 Finland Organisation responsible for the GS1 system in Finland.
317	GS1 Brazil Organisation responsible for the GS1 system in Brazil.
324	GS1 Ireland Organisation responsible for the GS1 system in Ireland.

Used Codes

325	GS1 Russia Organisation responsible for the GS1 system in Russia.
326	GS1 Poland Organisation responsible for the GS1 system in Poland.
327	GS1 Estonia Organisation responsible for the GS1 system in Estonia.
376	PANTONE Color code controlling organisation
400	FAO (Food and Agriculture Organisation) Food and Agriculture Organisation of the United Nations.
403	Comite European de Normalisation Comite Européen de Normalisation (CEN), European committee for standardisation. GS1 Note: Replaces GS1 Temporary Code CEN.
404	Assigned by logistics service provider Codes assigned by a logistics service provider. GS1 Note: Replaces GS1 Temporary Code X6.
CEN	Comite European de Normalisation (GS1 Temporary Code) Comite European de Normalisation. GS1 Note: Code marked for deletion. Use value 403 instead.
PMS	Pantone Matching System (GS1 Temporary Code) Pantone Matching System.
RAL	DE, Deutsches Institut fuer Guetesicherung und Kennzeichnung (GS1 Temporary Code) German Institute for Quality Assurance and Certification.
X5	IT, Ufficio IVA (GS1 Temporary Code) Ufficio responsabile gestione partite IVA, Italy (Italian Institute issuing VAT registration numbers).
X6	Assigned by logistics service provider (GS1 Temporary Code) Codes assigned by the logistics service provider. GS1 Note: Code marked for deletion. Use value 404 instead.
ZZZ	Mutually defined A code assigned within a code list to be used on an interim basis and as defined among trading partners until a precise code can be assigned to the code list.
3139	Contact function code Code specifying the function of a contact (e.g. department or person).
AA	Insurance contact Department/person to contact for matters regarding insurance.

Used Codes

AD	Accounting contact The contact responsible for accounting matters.
AE	Contract contact Department/person to contact for matters regarding contracts.
AM	Claims contact Department/person to contact for matters regarding claims.
AP	Accounts payable contact Department/person responsible for the accounts payable function within a corporation.
AR	Accounts receivable contact Department/person responsible for the accounts receivable within a corporation.
BC	Banking contact Contact person for bank.
BJ	Department or person responsible for processing purchase order Identification of the department or person responsible for the processing of purchase orders.
BN	Certification contact Code specifying a contact with knowledge of a certification action.
BO	After business hours contact Department/person to contact after normal working hours.
BR	Cook Person responsible for cooking. GS1 Note: Replaces GS1 Temporary Code CKE.
CB	Changed by Person who made the change.
CKE	Cook (GS1 Temporary Code) Person responsible for cooking. GS1 Note: Code marked for deletion. Use value BR instead.
CN	Consignee (3132) Party to which goods are consigned.
CO	Consignor (3336) Party which, by contract with a carrier, consigns or sends goods with the carrier, or has them conveyed by him. Synonym: shipper/sender.
CP	Responsible person for computer data processing Responsible person to contact for matters regarding computer data processing.
CR	Customer relations Individual responsible for customer relations.

Used Codes

DE	Department/employee to execute export procedures Department/employee which/who executes export procedures.
DI	Department/employee to execute import procedures Department/employee which/who executes import procedures.
DL	Delivery contact Department/person responsible for delivery.
ED	Engineering contact Department/person to contact for matters regarding engineering.
GR	Goods receiving contact Department/person responsible for receiving the goods at the place of delivery.
HE	Emergency dangerous goods contact Party who is to be contacted to intervene in case of emergency.
HG	Dangerous goods contact Department/person to be contacted for details about the transportation of dangerous goods/hazardous material.
IC	Information contact Department/person to contact for questions regarding transactions.
LO	Place of collection contact Department/employee to be contacted at the place of collection.
MGR	Manager (GS1 Temporary Code) Person responsible for management within a department or company.
NT	Notification contact Department/employee to be notified.
OC	Order contact An individual to contact for questions regarding this order.
PD	Purchasing contact Department/person responsible for issuing this purchase order.
PM	Product management contact Department/person to contact for questions regarding this order.
QC	Quality coordinator contact Quality coordinator contact within an organization.
SA	Sales administration Name of the sales administration contact within a corporation.
SD	Shipping contact The shipping department contact within an organization.
SR	Sales representative or department The sales representative or department contact within an organization.

Used Codes

TA	Traffic administrator The traffic administrator contact within an organization.
TD	Test contact Department/person responsible for testing contact.
TR	Transport contact Department/person in charge of transportation.
WH	Warehouse The warehouse contact within an organization.
3155	Communication address code qualifier Code qualifying the communication address.
AL	Cellular phone Identifies the cellular phone number.
AO	Uniform Resource Location (URL) Identification of the Uniform Resource Location (URL) Synonym: World wide web address. EDIFACT
AQ	X.400 address for mail text The X.400 address accepting information in the body text of a message.
AR	AS1 address Address capable of receiving messages in accordance with the EDIINT/AS1 protocol for MIME based EDI .
AS	AS2 address Address capable of receiving messages in accordance with the EDIINT/AS2 protocol.
AT	AS3 address Address capable of receiving messages in accordance with the EDIINT/AS3 protocol.
AU	File Transfer Protocol Address capable for receiving message in accordance with the File Transfer Protocol (IETF RFC 959 et. al.).
CA	Cable address The communication number identifies a cable address.
EI	EDI Number identifying the service and service user.

Used Codes

EM	Electronic mail Exchange of mail by electronic means. GS1 Description: Creating/sending/receiving of unstructured free text messages or documents using computer network, a mini-computer or an attached modem and regular telephone line or other electronic transmission media.
EXI	Exite mail (GS1 Temporary Code) Requests that the file shall be returned via Exite. GS1 Note: Code marked for deletion.
FX	Fax Device used for transmitting and reproducing fixed graphic material (as printing) by means of signals over telephone lines or other electronic transmission media.
IA	Interchange address (GS1 Temporary Code) Code identifying an EDI interchange address.
TE	Telephone Voice/data transmission by telephone.
TL	Telex Transmission of text/data via telex.
XF	X.400 The X.400 address. GS1 Description: CCITT Message handling system.
XG	Pager Identifies that the communication number is for a pager.
3207	Country name code Identification of the name of the country or other geographical entity as defined in ISO 3166-1. Notes: 1. Use ISO 3166-1 two alpha country code.
AD	Andorra
AE	United Arab Emirates
AF	Afghanistan
AG	Antigua and Barbuda
AI	Anguilla
AL	Albania
AM	Armenia
AO	Angola

Used Codes

AQ	Antarctica
AR	Argentina
AS	American Samoa
AT	Austria
AU	Australia
AW	Aruba
AX	Åland Islands
AZ	Azerbaijan
BA	Bosnia and Herzegovina
BB	Barbados
BD	Bangladesh
BE	Belgium
BF	Burkina Faso
BG	Bulgaria
BH	Bahrain
BI	Burundi
BJ	Benin
BL	Saint Barthélemy
BM	Bermuda
BN	Brunei Darussalam
BO	Bolivia (Plurinational State of)
BQ	Bonaire, Sint Eustatius and Saba
BR	Brazil
BS	Bahamas
BT	Bhutan
BV	Bouvet Island
BW	Botswana
BY	Belarus
BZ	Belize
CA	Canada
CC	Cocos (Keeling) Islands
CD	Congo, Democratic Republic of
CF	Central African Republic

Used Codes

CG	Congo
CH	Switzerland
CI	Cote D'Ivoire
CK	Cook Islands
CL	Chile
CM	Cameroon
CN	China
CO	Colombia
CR	Costa Rica
CU	Cuba
CV	Cape Verde
CW	Curaçao
CX	Christmas Island
CY	Cyprus
CZ	Czechia
DE	Germany
DJ	Djibouti
DK	Denmark
DM	Dominica
DO	Dominican Republic
DZ	Algeria
EC	Ecuador
EE	Estonia
EG	Egypt
EH	Western Sahara
ER	Eritrea
ES	Spain
ET	Ethiopia
FI	Finland
FJ	Fiji
FK	Falkland Islands (Malvinas)
FM	Micronesia (Federated States of)
FO	Faroe Islands

Used Codes

FR	France
GA	Gabon
GB	United Kingdom of Great Britain and Northern Ireland
GD	Grenada
GE	Georgia
GF	French Guiana
GG	Guernsey
GH	Ghana
GI	Gibraltar
GL	Greenland
GM	Gambia
GN	Guinea
GP	Guadeloupe
GQ	Equatorial Guinea
GR	Greece
GS	South Georgia and the South Sandwich Islands
GT	Guatemala
GU	Guam
GW	Guinea-Bissau
GY	Guyana
HK	Hong Kong
HM	Heard Island and McDonald Islands
HN	Honduras
HR	Croatia
HT	Haiti
HU	Hungary
ID	Indonesia
IE	Ireland
IL	Israel
IM	Isle Of Man
IN	India
IO	British Indian Ocean Territory
IQ	Iraq

Used Codes

IR	Iran (Islamic Republic of)
IS	Iceland
IT	Italy
JE	Jersey
JM	Jamaica
JO	Jordan
JP	Japan
KE	Kenya
KG	Kyrgyzstan
KH	Cambodia
KI	Kiribati
KM	Comoros
KN	Saint Kitts and Nevis
KP	Korea (Democratic People'S Republic of)
KR	Korea, Republic of
KW	Kuwait
KY	Cayman Islands
KZ	Kazakhstan
LA	Lao People'S Democratic Republic
LB	Lebanon
LC	Saint Lucia
LI	Liechtenstein
LK	Sri Lanka
LR	Liberia
LS	Lesotho
LT	Lithuania
LU	Luxembourg
LV	Latvia
LY	Libya
MA	Morocco
MC	Monaco
MD	Moldova, Republic of
ME	Montenegro

Used Codes

MF	Saint Martin (French Part)
MG	Madagascar
MH	Marshall Islands
MK	Macedonia, the Former Yugoslav Republic of
ML	Mali
MM	Myanmar
MN	Mongolia
MO	Macao
MP	Northern Mariana Islands
MQ	Martinique
MR	Mauritania
MS	Montserrat
MT	Malta
MU	Mauritius
MV	Maldives
MW	Malawi
MX	Mexico
MY	Malaysia
MZ	Mozambique
NA	Namibia
NC	New Caledonia
NE	Niger
NF	Norfolk Island
NG	Nigeria
NI	Nicaragua
NL	Netherlands
NO	Norway
NP	Nepal
NR	Nauru
NU	Niue
NZ	New Zealand
OM	Oman
PA	Panama

Used Codes

PE	Peru
PF	French Polynesia
PG	Papua New Guinea
PH	Philippines
PK	Pakistan
PL	Poland
PM	Saint Pierre and Miquelon
PN	Pitcairn
PR	Puerto Rico
PS	Palestine, State of
PT	Portugal
PW	Palau
PY	Paraguay
QA	Qatar
RE	Reunion
RO	Romania
RS	Serbia
RU	Russian Federation
RW	Rwanda
SA	Saudi Arabia
SB	Solomon Islands
SC	Seychelles
SD	Sudan
SE	Sweden
SG	Singapore
SH	Saint Helena, Ascension and Tristan da Cunha
SI	Slovenia
SJ	Svalbard and Jan Mayen
SK	Slovakia
SL	Sierra Leone
SM	San Marino
SN	Senegal
SO	Somalia

Used Codes

SR	Suriname
SS	South Sudan
ST	Sao Tome and Principe
SV	El Salvador
SX	Sint Maarten (Dutch part)
SY	Syrian Arab Republic
SZ	Swaziland
TC	Turks and Caicos Islands
TD	Chad
TF	French Southern Territories
TG	Togo
TH	Thailand
TJ	Tajikistan
TK	Tokelau
TL	Timor-Leste
TM	Turkmenistan
TN	Tunisia
TO	Tonga
TR	Turkey
TT	Trinidad and Tobago
TV	Tuvalu
TW	Taiwan, Province of China
TZ	Tanzania, United Republic of
UA	Ukraine
UG	Uganda
UM	United States Minor Outlying Islands
US	United States of America
UY	Uruguay
UZ	Uzbekistan
VA	Holy See
VC	Saint Vincent and the Grenadines
VE	Venezuela (Bolivarian Republic of)
VG	Virgin Islands, British

Used Codes

VI	Virgin Islands, U.S.
VN	Viet Nam
VU	Vanuatu
WF	Wallis and Futuna
WS	Samoa
YE	Yemen
YT	Mayotte
ZA	South Africa
ZM	Zambia
ZW	Zimbabwe

3223

First related location name code
Code specifying first related location.

Notes:

1. Recommend use UN/ECE Recommendation No. 16: UN/LOCODE. If not applicable, use appropriate code set in combination with 1131/3055.

LATDEC

Latitude DEC (GS1 Permanent Code)
Latitude of a location expressed in decimal degree
(DD.dddd) + N or S.

LATDMS

Latitude DMS (GS1 Permanent Code)
Latitude of a location expressed in degree, minute & second
(DDMMSS) + N or S.

3227

Location function code qualifier
Code identifying the function of a location.

1	Place of terms of delivery (3018) Point or port of departure, shipment or destination, as required under the applicable terms of delivery, e.g. Incoterms.
2	Payment place Place where funds are to be, or have been made available to the creditor.
5	Place of departure (3214) Port, airport or other location from which a means of transport or transport equipment is scheduled to depart or has departed.
7	Place of delivery (3246) Place to which the goods are to be finally delivered under transport contract terms (operational term).
8	Place of destination Port, airport or other location to which a means of transport or transport equipment is destined.

Used Codes

9	Place/port of loading (3334 + 3230) Seaport, airport, freight terminal, rail station or other place at which the goods (cargo) are loaded on to the means of transport being used for their carriage.
10	Place of acceptance (3348) Place at which the goods are taken over by the carrier.
11	Place/port of discharge (3392 + 3414) Seaport, airport, freight terminal, rail station or other place at which the goods (cargo) are unloaded from the means of transport having been used for their carriage.
13	Place of transshipment (3424) Place where goods are transferred from one means of transport to another (operational term).
14	Location of goods (3384) Place where goods are located and where they are available for examination.
17	Border crossing place Place where goods are transported across a country border.
18	Warehouse (3156) Warehouse where a particular consignment has been stored.
19	Factory/plant Factory/plant relevant for a particular consignment.
22	Customs office of clearance (3080) Place where Customs clearance procedure occur (CCC).
24	Port of entry Port where final documentation is filed for Customs Entry processing.
27	Country of origin [3238] Country in which the goods have been produced or manufactured, according to criteria laid down for the purposes of application of the Customs tariff, of quantitative restrictions, or of any other measure related to trade.
28	Country of destination of goods Country to which the goods are to be delivered.
30	Country of source Country in which raw material or components were originally produced prior to manufacture or assembly in another country.
33	Baseport of discharge The port of discharge according to the tariff as opposed to the operational port of discharge. The goods may or may not be actually discharged at that port on the main transport.

Used Codes

34	Baseport of loading The port of loading according to the tariff as opposed to the operational port of loading. The goods may or may not be actually loaded at that port on the main transport.
35	Country of exportation/despatch (3220) Country from which the goods were initially exported to the importing country without any commercial transaction taking place in intermediate countries. Syn.: country whence consigned. Country of despatch: country from which goods are despatched between countries of a Customs union.
36	Country of ultimate destination (3216) Country known to the consignor or his agent at the time of despatch to be the final country to which the goods are to be delivered.
37	Country of last consignment [3331] Country where the goods are loaded onto the means of transport used for their importation.
38	Country of first destination [3219] Country where the goods are offloaded from the means of transport used for their exportation.
39	Country of production Country where item has been or will be produced.
40	Country of trading Country where item has been or will be traded.
42	Customs office of exit [3096] Customs office at which the goods leave the country of dispatch/export.
45	Customs office of destination (transit) (3086) Customs office at which a transit operation is terminated. Synonym: Customs office of transit termination.
47	Region of destination Region known to the consignor or his agent at the time of despatch to be the final region to which the goods are to be delivered.
53	Charge and freight due from Place or point from which charges and freight are charged.
55	Charges and freight payable to [3274] Name of place up to which freight charges and other charges are to be paid.
57	Place of payment Name of the location at which freight and charges for main transport are payable.
60	Place of arrival Place at which the transport means arrives.

Used Codes

80	Place of despatch Place at which the goods are taken over for carriage (operational term), if different from the transport contract place of acceptance (see: 10). Synonym: Place of origin of carriage.
82	Pre-carriage port Port of loading at which the cargo is loaded on the pre-carriage vessel used for the transport prior to the main transport.
83	Place of delivery (by on-carriage) Place to which the goods are to be finally delivered.
88	Place of receipt Identification of the location at which the cargo is actually received.
92	Routing Indication of a routing place.
106	Region of origin Region in which the goods have been produced or manufactured according to the criteria laid down for the purposes of the application of the Customs tariff, of quantitative restrictions or of any other measures related to trade (see: 3238).
121	Country of sale [3116] Country where exporter's co-contractor is domiciled or has his business.
159	Additional internal destination Any location within the consignee's premises where the goods are moved to.
162	Place or location of sale Place or location at which the sale takes place.
184	Physical location Identifies the physical location.
241	Country of birth Country where a person or an animal was born.
242	Country of fattening Country where an animal has been fattened.
243	Country of slaughter Country where an animal has been slaughtered.
244	Country of meat cutting Country where the meat is cut into pieces. Country where an animal's carcass has been cut into smaller pieces.
245	Meat cutting location A location where the meat is cut into pieces. EDIFACT

Used Codes

246	Slaughterhouse Place for the slaughter of animals as food.
247	Country of meat mincing Country where meat has been cut into very small pieces using a meat grinder.
256	Place of packing Place where goods are packaged. EDIFACT
257	Country of assembly Country where product is assembled. Uses ISO country codes.
298	Country of last processing The country where the trade item was last processed.
299	Fishing vessel Fishing vessel as a place of production
300	Location of status The identification of the location of a status. GS1 Note: Replaces GS1 Temporary Code 16E.
301	Location of meter The identification of the location of a meter. GS1 Note: Replaces GS1 Temporary Code 17E.
303	Meat mincing plant A place where the meat is cut into very small pieces using a meat grinder. GS1 Note: Replaces GS1 Temporary Code 41E.
304	Place of fattening Place where an animal has been fattened. GS1 Note: Replaces GS1 Temporary Code 42E.
305	Animal birth place Location where an animal was born. GS1 Note: Replaces GS1 Temporary Code 43E.
306	Global Good Agricultural Practice Number (GGN) The Global Good Agricultural Practice Number (GGN) is a 13-digit number that uniquely identifies each producer and individual member of a producer group in the GLOBAL G.A.P. Database.
16E	Location of status (GS1 Temporary Code) Identification of the location of a status. GS1 Note: Code marked for deletion. Use value 300 instead.
17E	Location of meter (GS1 Temporary Code) The identification of the location of a meter. GS1 Note: Code marked for deletion. Use value 301 instead.

Used Codes

18E	Country of provenance (GS1 Temporary Code) The country of provenance of a consignment or product.
21E	Testing location (GS1 Temporary Code) The location where a test is being performed.
22E	Movement to location (GS1 Temporary Code) Identification of the location to where goods are to be moved.
23E	Return location (GS1 Temporary Code) The identification of a location for the return of goods.
41E	Mincing plant (GS1 Temporary Code) A place where the meat of animals is cut into very small pieces using a meat grinder. GS1 Note: Code marked for deletion. Use value 303 instead.
42E	Place of fattening (GS1 Temporary Code) Place where the animal has been fattened before killing for food. GS1 Note: Code marked for deletion. Use value 304 instead.
43E	Animal's Birth Place (GS1 Temporary Code) Place/Location where an animal was born (GLN or Veterinary licence number) GS1 Note: Code marked for deletion. Use value 305 instead.
3233	Second related location name code Code specifying the second related location. Notes: 1. Recommend use UN/ECE Recommendation No. 16: UN/LOCODE. If not applicable, use appropriate code set in combination with 1131/3055.
LONDEC	Longitude DEC (GS1 Permanent Code) Longitude of a location expressed in decimal degree (DDD.dddd) + E or W.
LONDMS	Longitude DMS (GS1 Permanent Code) Longitude of a location expressed in degree, minute & second (DDDMSS) + E or W.
3239	Country of origin name code Code specifying the name of the country of origin. Notes: 1. Use ISO 3166-1 two alpha country code.
AD	Andorra
AE	United Arab Emirates
AF	Afghanistan
AG	Antigua and Barbuda
AI	Anguilla

Used Codes

AL	Albania
AM	Armenia
AO	Angola
AQ	Antarctica
AR	Argentina
AS	American Samoa
AT	Austria
AU	Australia
AW	Aruba
AX	Åland Islands
AZ	Azerbaijan
BA	Bosnia and Herzegovina
BB	Barbados
BD	Bangladesh
BE	Belgium
BF	Burkina Faso
BG	Bulgaria
BH	Bahrain
BI	Burundi
BJ	Benin
BL	Saint Barthélemy
BM	Bermuda
BN	Brunei Darussalam
BO	Bolivia (Plurinational State of)
BQ	Bonaire, Sint Eustatius and Saba
BR	Brazil
BS	Bahamas
BT	Bhutan
BV	Bouvet Island
BW	Botswana
BY	Belarus
BZ	Belize
CA	Canada

Used Codes

CC	Cocos (Keeling) Islands
CD	Congo, Democratic Republic of
CF	Central African Republic
CG	Congo
CH	Switzerland
CI	Cote D'Ivoire
CK	Cook Islands
CL	Chile
CM	Cameroon
CN	China
CO	Colombia
CR	Costa Rica
CU	Cuba
CV	Cape Verde
CW	Curaçao
CX	Christmas Island
CY	Cyprus
CZ	Czechia
DE	Germany
DJ	Djibouti
DK	Denmark
DM	Dominica
DO	Dominican Republic
DZ	Algeria
EC	Ecuador
EE	Estonia
EG	Egypt
EH	Western Sahara
ER	Eritrea
ES	Spain
ET	Ethiopia
FI	Finland
FJ	Fiji

Used Codes

FK	Falkland Islands (Malvinas)
FM	Micronesia (Federated States of)
FO	Faroe Islands
FR	France
GA	Gabon
GB	United Kingdom of Great Britain and Northern Ireland
GD	Grenada
GE	Georgia
GF	French Guiana
GG	Guernsey
GH	Ghana
GI	Gibraltar
GL	Greenland
GM	Gambia
GN	Guinea
GP	Guadeloupe
GQ	Equatorial Guinea
GR	Greece
GS	South Georgia and the South Sandwich Islands
GT	Guatemala
GU	Guam
GW	Guinea-Bissau
GY	Guyana
HK	Hong Kong
HM	Heard Island and McDonald Islands
HN	Honduras
HR	Croatia
HT	Haiti
HU	Hungary
ID	Indonesia
IE	Ireland
IL	Israel
IM	Isle Of Man

Used Codes

IN	India
IO	British Indian Ocean Territory
IQ	Iraq
IR	Iran (Islamic Republic of)
IS	Iceland
IT	Italy
JE	Jersey
JM	Jamaica
JO	Jordan
JP	Japan
KE	Kenya
KG	Kyrgyzstan
KH	Cambodia
KI	Kiribati
KM	Comoros
KN	Saint Kitts and Nevis
KP	Korea (Democratic People'S Republic of)
KR	Korea, Republic of
KW	Kuwait
KY	Cayman Islands
KZ	Kazakhstan
LA	Lao People'S Democratic Republic
LB	Lebanon
LC	Saint Lucia
LI	Liechtenstein
LK	Sri Lanka
LR	Liberia
LS	Lesotho
LT	Lithuania
LU	Luxembourg
LV	Latvia
LY	Libya
MA	Morocco

Used Codes

MC	Monaco
MD	Moldova, Republic of
ME	Montenegro
MF	Saint Martin (French Part)
MG	Madagascar
MH	Marshall Islands
MK	Macedonia, the Former Yugoslav Republic of
ML	Mali
MM	Myanmar
MN	Mongolia
MO	Macao
MP	Northern Mariana Islands
MQ	Martinique
MR	Mauritania
MS	Montserrat
MT	Malta
MU	Mauritius
MV	Maldives
MW	Malawi
MX	Mexico
MY	Malaysia
MZ	Mozambique
NA	Namibia
NC	New Caledonia
NE	Niger
NF	Norfolk Island
NG	Nigeria
NI	Nicaragua
NL	Netherlands
NO	Norway
NP	Nepal
NR	Nauru
NU	Niue

Used Codes

NZ	New Zealand
OM	Oman
PA	Panama
PE	Peru
PF	French Polynesia
PG	Papua New Guinea
PH	Philippines
PK	Pakistan
PL	Poland
PM	Saint Pierre and Miquelon
PN	Pitcairn
PR	Puerto Rico
PS	Palestine, State of
PT	Portugal
PW	Palau
PY	Paraguay
QA	Qatar
RE	Reunion
RO	Romania
RS	Serbia
RU	Russian Federation
RW	Rwanda
SA	Saudi Arabia
SB	Solomon Islands
SC	Seychelles
SD	Sudan
SE	Sweden
SG	Singapore
SH	Saint Helena, Ascension and Tristan da Cunha
SI	Slovenia
SJ	Svalbard and Jan Mayen
SK	Slovakia
SL	Sierra Leone

Used Codes

SM	San Marino
SN	Senegal
SO	Somalia
SR	Suriname
SS	South Sudan
ST	Sao Tome and Principe
SV	El Salvador
SX	Sint Maarten (Dutch part)
SY	Syrian Arab Republic
SZ	Swaziland
TC	Turks and Caicos Islands
TD	Chad
TF	French Southern Territories
TG	Togo
TH	Thailand
TJ	Tajikistan
TK	Tokelau
TL	Timor-Leste
TM	Turkmenistan
TN	Tunisia
TO	Tonga
TR	Turkey
TT	Trinidad and Tobago
TV	Tuvalu
TW	Taiwan, Province of China
TZ	Tanzania, United Republic of
UA	Ukraine
UG	Uganda
UM	United States Minor Outlying Islands
US	United States of America
UY	Uruguay
UZ	Uzbekistan
VA	Holy See

Used Codes

VC	Saint Vincent and the Grenadines
VE	Venezuela (Bolivarian Republic of)
VG	Virgin Islands, British
VI	Virgin Islands, U.S.
VN	Viet Nam
VU	Vanuatu
WF	Wallis and Futuna
WS	Samoa
YE	Yemen
YT	Mayotte
ZA	South Africa
ZM	Zambia
ZW	Zimbabwe

3433

Institution name code
Code specifying the name of an institution.

BK

Bank (GS1 Permanent Code)
The financial institution being identified is a bank.

PO

Post office (GS1 Permanent Code)
The financial institution being identified is a post office.

3453

Language name code
Code specifying the language name.

Notes:

1. Use ISO 639-1988.

AA

Afar

aa

Afar

AB

Abkhazian

ab

Abkhazian

AE

Avestan

ae

Avestan

AF

Afrikaans

af

Afrikaans

AK

Akan

ak

Akan

Used Codes

AM	Amharic
am	Amharic
AN	Aragonese
an	Aragonese
AR	Arabic
ar	Arabic
AS	Assamese
as	Assamese
AV	Avaric
av	Avaric
AY	Aymara
ay	Aymara
AZ	Azerbaijani
az	Azerbaijani
BA	Bashkir
ba	Bashkir
BE	Belarusian
be	Belarusian
BG	Bulgarian
bg	Bulgarian
BH	Bihari
bh	Bihari
BI	Bislama
bi	Bislama
BM	Bambara
bm	Bambara
BN	Bengali
bn	Bengali
BO	Tibetan
bo	Tibetan
BR	Breton
br	Breton
BS	Bosnian

Used Codes

bs	Bosnian
CA	Catalan; Valencian
ca	Catalan; Valencian
CE	Chechen
ce	Chechen
CH	Chamorro
ch	Chamorro
CO	Corsican
co	Corsican
CR	Cree
cr	Cree
CS	Czech
cs	Czech
CU	Church Slavic; Old Slavonic; Church Slavonic; Old Bulgarian; Old Church Slavonic
cu	Church Slavic; Old Slavonic; Church Slavonic; Old Bulgarian; Old Church Slavonic
CV	Chuvash
cv	Chuvash
CY	Welsh
cy	Welsh
DA	Danish
da	Danish
DE	German
de	German
DV	Divehi; Dhivehi; Maldivian
dv	Divehi; Dhivehi; Maldivian
DZ	Dzongkha
dz	Dzongkha
EE	Ewe
ee	Ewe
EL	Greek; Modern (1453-)
el	Greek; Modern (1453-)
EN	English

Used Codes

en	English
EO	Esperanto
eo	Esperanto
ES	Spanish; Castilian
es	Spanish; Castilian
ET	Estonian
et	Estonian
EU	Basque
eu	Basque
FA	Persian
fa	Persian
FF	Fulah
ff	Fulah
FI	Finnish
fi	Finnish
FJ	Fijian
fj	Fijian
FO	Faroese
fo	Faroese
FR	French
fr	French
FY	Western Frisian
fy	Western Frisian
GA	Irish
ga	Irish
GD	Gaelic; Scottish Gaelic
gd	Gaelic; Scottish Gaelic
GL	Galician
gl	Galician
GN	Guarani
gn	Guarani
GU	Gujarati
gu	Gujarati

Used Codes

GV	Manx
gv	Manx
HA	Hausa
ha	Hausa
HE	Hebrew
he	Hebrew
HI	Hindi
hi	Hindi
HO	Hiri Motu
ho	Hiri Motu
HR	Croatian
hr	Croatian
HT	Haitian; Haitian Creole
ht	Haitian; Haitian Creole
HU	Hungarian
hu	Hungarian
HY	Armenian
hy	Armenian
HZ	Herero
hz	Herero
IA	Interlingua (International Auxiliary Language Association)
ia	Interlingua (International Auxiliary Language Association)
ID	Indonesian
id	Indonesian
IE	Interlingue
ie	Interlingue
IG	Igbo
ig	Igbo
II	Sichuan Yi
ii	Sichuan Yi
IK	Inupiaq
ik	Inupiaq
IO	Ido

Used Codes

io	Ido
IS	Icelandic
is	Icelandic
IT	Italian
it	Italian
IU	Inuktiut
iu	Inuktiut
JA	Japanese
ja	Japanese
JV	Javanese
jv	Javanese
KA	Georgian
ka	Georgian
KG	Kongo
kg	Kongo
KI	Kikuyu; Gikuyu
ki	Kikuyu; Gikuyu
KJ	Kuanyama; Kwanyama
kj	Kuanyama; Kwanyama
KK	Kazakh
kk	Kazakh
KL	Kalaallisut; Greenlandic
kl	Kalaallisut; Greenlandic
KM	Central Khmer
km	Central Khmer
KN	Kannada
kn	Kannada
KO	Korean
ko	Korean
KR	Kanuri
kr	Kanuri
KS	Kashmiri
ks	Kashmiri

Used Codes

KU	Kurdish
ku	Kurdish
KV	Komi
kv	Komi
KW	Cornish
kw	Cornish
KY	Kirghiz; Kyrgyz
ky	Kirghiz; Kyrgyz
LA	Latin
la	Latin
LB	Luxembourgish; Letzeburgesch
lb	Luxembourgish; Letzeburgesch
LG	Ganda
lg	Ganda
LI	Limburgan; Limburger; Limburgish
li	Limburgan; Limburger; Limburgish
LN	Lingala
ln	Lingala
LO	Lao
lo	Lao
LT	Lithuanian
lt	Lithuanian
LU	Luba-Katanga
lu	Luba-Katanga
LV	Latvian
lv	Latvian
MG	Malagasy
mg	Malagasy
MH	Marshallese
mh	Marshallese
MI	Maori
mi	Maori
MK	Macedonian

Used Codes

mk	Macedonian
ML	Malayalam
ml	Malayalam
MN	Mongolian
mn	Mongolian
MO	Moldavian; Moldovan
mo	Moldavian; Moldovan
MR	Marathi
mr	Marathi
MS	Malay
ms	Malay
MT	Maltese
mt	Maltese
MY	Burmese
my	Burmese
NA	Nauru
na	Nauru
NB	Bokmal Norwegian; Norwegian Bokmal
nb	Bokmal Norwegian; Norwegian Bokmal
ND	Ndebele; North; North Ndebele
nd	Ndebele; North; North Ndebele
NE	Nepali
ne	Nepali
NG	Ndonga
ng	Ndonga
NL	Dutch; Flemish
nl	Dutch; Flemish
NN	Norwegian Nynorsk; Nynorsk, Norwegian
nn	Norwegian Nynorsk; Nynorsk, Norwegian
NO	Norwegian
no	Norwegian
NR	Ndebele; South; South Ndebele
nr	Ndebele; South; South Ndebele

Used Codes

NV	Navajo; Navaho
nv	Navajo; Navaho
NY	Chichewa; Chewa; Nyanja
ny	Chichewa; Chewa; Nyanja
OC	Occitan (post 1500); Provençal
oc	Occitan (post 1500); Provençal
OJ	Ojibwa
oj	Ojibwa
OM	Oromo
om	Oromo
OR	Oriya
or	Oriya
OS	Ossetian; Ossetic
os	Ossetian; Ossetic
PA	Panjabi; Punjabi
pa	Panjabi; Punjabi
PI	Pali
pi	Pali
PL	Polish
pl	Polish
PS	Pushto; Pashto
ps	Pushto; Pashto
PT	Portuguese
pt	Portuguese
QU	Quechua
qu	Quechua
RM	Romansh
rm	Romansh
RN	Rundi
rn	Rundi
RO	Romanian
ro	Romanian
RU	Russian

Used Codes

ru	Russian
RW	Kinyarwanda
rw	Kinyarwanda
SA	Sanskrit
sa	Sanskrit
SC	Sardinian
sc	Sardinian
SD	Sindhi
sd	Sindhi
SE	Northern Sami
se	Northern Sami
SG	Sango
sg	Sango
SI	Sinhala; Sinhalese
si	Sinhala; Sinhalese
SK	Slovak
sk	Slovak
SL	Slovenian
sl	Slovenian
SM	Samoaan
sm	Samoaan
SN	Shona
sn	Shona
SO	Somali
so	Somali
SQ	Albanian
sq	Albanian
SR	Serbian
sr	Serbian
SS	Swati
ss	Swati
ST	Sotho, Southern
st	Sotho, Southern

Used Codes

SU	Sundanese
su	Sundanese
SV	Swedish
sv	Swedish
SW	Swahili
sw	Swahili
TA	Tamil
ta	Tamil
TE	Telugu
te	Telugu
TG	Tajik
tg	Tajik
TH	Thai
th	Thai
TI	Tigrinya
ti	Tigrinya
TK	Turkmen
tk	Turkmen
TL	Tagalog
tl	Tagalog
TN	Tswana
tn	Tswana
TO	Tonga (Tonga Islands)
to	Tonga (Tonga Islands)
TR	Turkish
tr	Turkish
TS	Tsonga
ts	Tsonga
TT	Tatar
tt	Tatar
TW	Twi
tw	Twi
TY	Tahitian

Used Codes

ty	Tahitian
UG	Uighur; Uyghur
ug	Uighur; Uyghur
UK	Ukrainian
uk	Ukrainian
UR	Urdu
ur	Urdu
UZ	Uzbek
uz	Uzbek
VE	Venda
ve	Venda
VI	Vietnamese
vi	Vietnamese
VO	Volapük
vo	Volapük
WA	Walloon
wa	Walloon
WO	Wolof
wo	Wolof
XH	Xhosa
xh	Xhosa
YI	Yiddish
yi	Yiddish
YO	Yoruba
yo	Yoruba
ZA	Zhuang; Chuang
za	Zhuang; Chuang
ZH	Chinese
zh	Chinese
ZU	Zulu
zu	Zulu

4043

Trade class code
Code identifying the class of trade.

Used Codes

AE	Contractor A person or group acting as a contractor. GS1 Hinweis: Ersetzt den GS1 Temporary Code CR.
CR	Contractor (GS1 Temporary Code) A person or group acting as a contractor. GS1 Note: Code marked for deletion. Use value AE instead.
DI	Distributor A person or group acting explicitly as distributor of merchandise or goods.
MF	Manufacturer A company that produces goods from raw materials.
RDN	Return the delivery note signed by the goods recipient (GS1 Temporary Code) Indication that the delivery note has to be returned signed by the goods recipient Code marked for deletion.
RPD	Return the number of the "proof of delivery" generated by the goods recipient (GS1 Temporary Code) Indication that the number of the "proof of delivery" generated by the goods recipient has to be returned. Code marked for deletion.
RS	Resale Self explanatory. GS1 Description: A person or group reselling goods.
WH	Wholesaler A person or group buying goods in large quantities for resale by a retailer.
WT	Out patient A patient not under the full time care of a hospital but visits from time to time for treatment. GS1 Description: A person who is medically treated out of the hospital.
WU	In patient A patient under the full time care of a hospital. GS1 Description: A person who is medically treated in the hospital.

4053

Delivery or transport terms description code
Code specifying the delivery or transport terms.

Notes:

1. Recommend use UN/ECE Recommendation No. 5 Incoterms 1990. If directory codes or Recommendation No. 5 codes are not applicable, use appropriate code set in combination with 1131/3055.

Used Codes

01E	Contact delivery party before delivery (GS1 Temporary Code) Indication that the delivery party should be contacted before delivery.
02E	Despatch goods urgent delivery (GS1 Temporary Code) Requests that the goods be despatched urgently.
03E	Special delivery conditions (GS1 Temporary Code) Indication that the delivery is subject to special conditions agreed between the trading partners.
04E	Cash on delivery (GS1 Temporary Code) Indication that the delivery is subject to cash on delivery conditions.
RDN	Return the delivery note signed by the goods recipient (GS1 Temporary Code) Indication that the delivery note has to be returned signed by the goods recipient.
RPD	Return the number of the "proof of delivery" generated by the goods recipient has to be returned (GS1 Temporary Code) Indication that the number of the "proof of delivery" generated by the goods recipient has to be returned.
SD	Shipment of order split over more than one means of transport (GS1 Temporary Code) Shipment of an order has been split over more than one means of transport.
4055	Delivery or transport terms function code Code specifying the function of delivery or transport terms.
1	Price condition Specifies a condition related to the price which a seller must fulfil before the buyer will complete a purchase. GS1 Description: Specific price condition under which goods must be delivered to the consignee.
2	Despatch condition Condition requested by the customer under which the supplier shall deliver: Extent of freight costs, means of transport.
3	Price and despatch condition Condition related to price and despatch that the seller must complete before the customer will agree payment. GS1 Description: Terms of delivery relate to both price and despatch condition.
4	Collected by customer Indicates that the customer will pick up the goods at the supplier. He will take care of the means of transport.
5	Transport condition Specifies the conditions under which the transport takes place under the responsibility of the carrier.

Used Codes

6	Delivery condition Specifies the conditions under which the goods must be delivered to the consignee.
7	Delivered by supplier Indicates that the supplier will arrange the delivery of goods. He will take care of the means of transport. GS1 Note: Replaces GS1 Temporary Code 10E.
8	Delivery arranged by logistic service provider Code indicating that the logistic service provider will arrange the delivery of goods. GS1 Note: Replaces GS1 Temporary Code 11E.
10E	Delivered by supplier (GS1 Temporary Code) Indicates that the supplier will arrange the delivery of goods. He will take care of the means of transport. GS1 Note: Code marked for deletion. Use value 7 instead
11E	Delivery arranged by logistic service provider (GS1 Temporary Code) Code indicating that the logistic service provider will arrange the delivery of goods. GS1 Note: Code marked for deletion. Use value 8 instead.
4183	Special condition code Code specifying a special condition.
1	Item for national preference Item concerned is applicable to national preference calculation.
2	Item qualifying for payment discount Item concerned is applicable for settlement/payment discount calculation.
3	Item not qualifying for payment discount Item concerned is not applicable for settlement/payment discount calculation.
4	Urgent delivery of reserved goods Urgent delivery of goods for which a reservation was made.
5	Item not to be included in bonus calculation Item concerned is not applicable for bonus calculation.
6	Subject to bonus Item concerned is applicable for bonus calculation.
7	Subject to commission Item concerned is applicable for commission calculation.
8	Subject to discount Item concerned is applicable for discount calculation.

Used Codes

9	Freely available in EU Item should be available freely within the European Economic Community. GS1 Description: Item is freely available in the European Union.
10	Subject to settlement discount Item concerned is applicable for the overall settlement discount.
11	Price includes excise The stated price is inclusive of excise.
12	Price includes tax The stated price is inclusive of tax.
15	Not subject to discount Item concerned is not applicable for discount calculation.
18	Item subject to national export restrictions Item concerned requires export declaration.
96	Promotional advertising A media press communication informing about a promotion.
97	Promotional price Reduction in price for a specified period of time for promotional purposes.
98	Promotional shelf display Product in promotion is displayed in a special shelf or display.
99	Safety data sheet required to accompany goods when moved Material safety data sheet is required to accompany the goods when they are moved.
109	Sale or return Item concerned may be returned to supplier or otherwise disposed of if it remains unsold after a pre-determined period of time.
116	Subject to postponed discount The item concerned is applicable for postponed discount which will be refunded via a later credit.
119	Product genetically modified An indication that a product has been genetically modified during its production process.
123	Pharmacy sales only A special condition limiting the sale of a product to a pharmacy.
124	Sale requires medical prescription The sale of the product requires a medical prescription. GS1 Description: The identified product may only be sold in conjunction with a medical prescription.

Used Codes

125	New item, not yet available The item is new and not yet available.
126	New, available The item is new and available.
127	Obsolete The item is obsolete.
128	Prototype The item is a prototype and is not yet in normal production.
129	Non-standard product This item is not a standard product.
130	Discontinued The item is no longer available.
133	Gift supplied with purchase Product made available as a gift to a customer when purchasing an accompanying product.
134	Sale from promotional stock An indication that products sold came from promotional stock.
135	Sale from obsolete stock An indication that products sold came from obsolete stock.
136	Buying group conditions A code indicating that buying group conditions apply.
137	Cancel order unless complete delivery possible on requested date and or time Code indicating that the order is to be cancelled if complete delivery is not possible on the date and or time requested in the order.
140	Return of goods Special conditions related to the return of goods.
141	Subject to annual bonus Item concerned is applicable for annual bonus calculation.
142	Invoiced but not replenished A special condition indicating the fact that goods which have not yet been replenished have been invoiced.
143	Replenished but not invoiced A special condition indicating the fact that goods which have been replenished have not yet been invoiced.
144	Deliver full order A special condition indicating that delivery of the order will only be accepted in full.

Used Codes

147	Special handling requirements at point of receipt An indication that the product requires special handling at the point of receipt.
148	Supply direct delivery Goods to be supplied direct delivery to the delivery store and not through a distribution centre or a warehouse.
150	Mixed item pallet Goods to be supplied on mixed item pallet.
151	Items from the same dye lot The items should be supplied from the same dye lot.
152	Awaiting credit clearance Processing of the referenced document is delayed while credit clearance is obtained.
153	Return publication full copies Return the full copies of a publication.
154	Return publication headings only Return only the heading of a publication.
155	Destroy publication Destroy the publication by whatever means, but in such a way that it cannot be read afterwards.
157	Not subject to sale or return Product supplied not subject to sale or return.
158	Item to be sold in both domestic and export markets The item will be sold in both the domestic and export markets.
159	Item to be sold only in export markets The item will be sold only in export markets.
164	Shipment completes order There will be no further shipments for this order as it is considered complete.
165	Split shipment Subsequent shipment(s) will arrive for this order as it has been split over more than one shipment.
166	Include in continuous replenishment calculation An indication that a product or group of products are to be included in the continuous replenishment calculation.
167	Remove from continuous replenishment calculation An indication that a product or group of products are to be removed from the continuous replenishment calculation.
168	Standard pack shipment The shipment contains only standard packs.

Used Codes

169	Pick pack shipment The shipment contains only packages resulting from a pick and pack operation. GS1 Description: Where the hierarchy of the shipment resulting from a pick and pack operation has the article level sub-ordinate to the packaging level.
170	Goods for retail outlet shelf Goods to be placed on a retail outlet shelf.
171	Security stock The goods are required to maintain the security stock.
172	Production batch number allocated A batch number is allocated by the manufacturer to the item.
173	Production batch number allocated as required by law A batch number is allocated by the manufacturer to the item as required by law.
174	Product not genetically modified An indication that a product has not been genetically modified during its production process.
175	Suspended An item whose production or distribution has been suspended. EDIFACT
176	No re-ordering The item will not be re-ordered. EDIFACT
177	Product irradiated for preservation An indication that a product has had radioactive rays directed onto it to preserve it. EDIFACT
179	Product gluten-free An indication that a product does not contain any gluten.
180	Product contains gluten An indication that a product contains gluten.
181	Product lactose-free An indication that a product does not contain any lactose.
182	Product contains lactose An indication that a product contains lactose.
183	CH, compliant with Genetically Modified Food law An indication that a product complies with the Swiss law on genetically modified food.

Used Codes

184	CH, non-compliant with Genetically Modified Food law An indication that a product does not comply with the Swiss law on genetically modified food.
185	CH, compliant with General Food law An indication that a product complies with the Swiss general food law.
186	CH, non-compliant with General Food law An indication that a product does not comply with the Swiss general food law.
187	Store may not order The store is not allowed to order.
188	Distribution centre may not order Distribution centre is not allowed to order.
189	Net content declaration indicated A declaration of a trade item's net content is on the product label.
190	Net content declaration not indicated A declaration of a trade item's net content is not on the product label.
191	Not irradiated Radiation has not been applied.
192	Batch or lot number not allocated The trade item has no batch or lot number.
193	Unsold trade item not returnable A trade item that is not sold cannot be returned.
194	Ingredient irradiated Radiation has been applied to a trade item's ingredient.
195	Ingredients not irradiated Radiation has not been applied to any trade item's ingredient.
196	Raw material irradiated Radiation has been applied to a trade item's raw material.
197	Raw material not irradiated Radiation has not been applied to any trade item's raw material.
198	Re-orderable The item may be re-ordered.
199	Receipt advice, fully detailed Includes qualitative and/or quantitative details regarding everything received (all line items) whether or not there were exceptions between what was received and what was advised as being sent.
200	Receipt advice, only exceptions Includes only qualitative and/or quantitative exceptions between what was received and what was advised as being sent.

Used Codes

201	Ingredient is irradiated not applicable The indication that an ingredient of a trade item is irradiated is not applicable.
202	Raw material is irradiated not applicable The indication that raw material of a trade item is irradiated is not applicable.
203	Trade item is genetically modified not applicable The indication that a product has not been genetically modified is not applicable
204	Ingredient is irradiated not applicable The indication that a trade item is irradiated is not applicable.
205	Size dependent pricing An item price may be different depending of the size.
206	Size independent pricing An item price is independent of the size.
207	Only accepted products Includes only details regarding accepted products.
208	Financial compensation Special condition related to a financial compensation.
209	Wrong order Complete order credited due to a wrong order that was previously invoiced.
210	Quality defect Special condition due to quality defect of delivered trade items.
211	Wrong price Special condition related to a previously invoiced incorrect price.
53E	Await further instructions (GS1 Temporary Code) Wait for further instructions as to what to do with the publications. These instructions will either be given in electronic form or by other means such as letter, fax, e-mail.
55E	No action (GS1 Temporary Code) Code indicating the fact that no actions have taken place since the last message.
59E	No pallets (GS1 Temporary Code) Goods are to be supplied without pallets.
61E	Mono item pallet (GS1 Temporary Code) Goods to be supplied on mono item pallet.
69E	Product data publically available (GS1 Temporary Code) A code indicating the fact that the data associated with the current product may be made publically available on a product data base.

Used Codes

70E	Product data not publically available (GS1 Temporary Code) A code indicating the fact that the data associated with the current product may not be made publically available on a product data base.
73E	Delivery subject to final authorization (GS1 Temporary Code) Code indicating the fact that delivery of the order should not take place until final authorization has been received from the delivery party or buyer.
74E	Subject to special rules for hazardous materials (GS1 Temporary Code) A code to indicate that the product is subject to special hazardous materials rules.
75E	Not subject to special rules for hazardous materials (GS1 Temporary Code) A code to indicate that the product is not subject to special hazardous materials rules.
76E	Special conditions applicable to only this invoice (GS1 Temporary Code) This invoice is subject to some special conditions.
77E	Installation order conditions (GS1 Temporary Code) A code indicating order conditions related the installation for the first time, or complete restocking, of the entire range of a retail outlet.
79E	Discrepancies or adjustments (GS1 Temporary Code) Special conditions related to discrepancies or adjustments.
88E	Commodity (GS1 Temporary Code) Company's standard product.
90E	Temporarily out (GS1 Temporary Code) Item is temporarily not available.
91E	Manufacture out (GS1 Temporary Code) Item is out of production.
93E	Seasonally available only (GS1 Temporary Code) Product described is only available in specific seasons or time periods in a year, e.g. christmas decorations.
94E	Deletion, announcement only (GS1 Temporary Code) An announcement to say that the item is in the process of being deleted from the supplier's product range
95E	Temporary product (GS1 Temporary Code) A product which is only available for a temporary period of time.
96E	Product again available (GS1 Temporary Code) A product which was previously unavailable which is once again available.
ACD	Party has access to all non publically available data (GS1 Temporary Code) The identified party has access to all non publically available pricing and non-pricing data associated with the current product.

Used Codes

ACN	Party has access only to non publically available non-pricing data (GS1 Temporary Code) The identified party has access only to the non publically available non-pricing data associated with the current product.
ACP	Party has access only to non publically available pricing data (GS1 Temporary Code) The identified party has access only to the non publically available pricing data associated with the current product.
X1	No back orders when partial delivery (GS1 Temporary Code) Indication that no back orders are allowed when there is a partial delivery.
X10	Include article surveillance (GS1 Temporary Code) Product should contain article surveillance.
X18	Final consumer reservation (GS1 Temporary Code) Goods to be supplied with maximum urgency because final consumer has made reservation (in a retail outlet).
X19	Shelf replenishment merchandise (GS1 Temporary Code) Goods to be placed in a retail outlet shelf.
X2	Back orders accepted when partial delivery (GS1 Temporary Code) Indication that back orders are accepted when there is a partial delivery.
X20	Security stock merchandise (GS1 Temporary Code) Goods to maintain the security stock of a retail outlet.
X44	Item to be included in bonus calculation (GS1 Temporary Code) Item will be included when calculating agreed bonuses.
X5	End consumer promotional item (GS1 Temporary Code) Item is an end consumer promotional item.
X61	Is reload (GS1 Temporary Code) Value indicating the state of the Catalogue Item within the Request for Notification Process being currently on the Notification List.
X62	Is not reload (GS1 Temporary Code) Value indicating the state of the Catalogue Item within the Request for Notification Process being Initial Load.
X8	Provisional (GS1 Temporary Code) Item concerned is provisional.
X9	No empties (GS1 Temporary Code) No empty packaging to exchange, e.g. no empty bottles for ordered drinks.
4215	Transport charges payment method code Code specifying the payment method for transport charges.

Used Codes

AA	Cash on delivery service charge paid by consignor An indication that the consignor is responsible for the payment of the cash on delivery service charge.
AB	Cash on delivery service charge paid by consignee An indication that the consignee is responsible for the payment of the cash on delivery service charge.
AC	Insurance costs paid by consignor An indication that the consignor is responsible for the payment of the insurance costs.
AD	Insurance costs paid by consignee An indication that the consignee is responsible for the payment of the insurance costs.
AE	Goods collected from store Customer collects goods from the store. GS1 Note: Replaces GS1 Temporary Code X1.
CA	Advance collect The amount of freight or other charge on a shipment advanced by one transportation line to another or to the shipper, to be collected from consignee.
CC	Collect A shipment on which freight charges will be paid by consignee.
CF	Collect, freight credited to payment customer The freight is collect but has been paid by the shipper and will be credited to that party. GS1 Description: A shipment on which freight charges will be paid by the consignee.
DF	Defined by buyer and supplier The payment method for transport charges have been defined by the buyer and seller.
MX	Mixed The consignment is partially collect and partially prepaid.
NC	Service freight, no charge The consignment is shipped on a service basis and there is no freight charge. GS1 Description: No charge is due owing to the use of service freight.
PC	Prepaid but charged to customer Shipping charges have been paid in advance of shipment but are charged back to consignee usually as line item on invoice for the purchased goods.
PO	Prepaid only Payment in advance of freight and/or other charges prior to delivery of shipment at destination, usually by shipper at point of origin.

Used Codes

PP	Prepaid (by seller) Seller of goods makes payment to carrier for freight charges prior to shipment.
PU	Pickup Customer is responsible for payment of pickup charges at shipping point.
RC	Return container freight paid by customer The freight for returning the container is paid by the customer.
RF	Return container freight free There is no freight charge for returning the container.
RS	Return container freight paid by supplier The freight charge for returning the container is paid by the supplier.
TP	Third party pay A third party, someone other than buyer or seller, is identified as responsible for payment of shipping charges.
WD	Paid by supplier Transport charges will be paid by the supplier.
WE	Paid by buyer Transport charges will be paid by the buyer.
X1	Goods collected from store (GS1 Temporary Code) Customer collects goods from the store GS1 Note: Code marked for deletion. Use value AE instead.
4221	Discrepancy nature identification code Code specifying the identification used to define the nature of a discrepancy.
AA	Item discontinued by wholesaler The wholesaler no longer offers the ordered product.
AB	Item no longer produced The item ordered has been discontinued and is no longer in production.
AC	Over-shipped Code indicating that there was an excess quantity of goods in a shipment relative to the order.
AD	Item out of stock at manufacturer The item is out of stock at manufacturer.
AE	Delivered but not advised Shipment or goods have been delivered without any advance notification of delivery.
AF	Goods delivered damaged Part or all of the goods in a shipment were delivered damaged.

Used Codes

AG	Delivered too late Delivered but at a later date than the delivery date under the agreed conditions or stipulated in the order.
AH	Next higher packaging quantity The ordered item has been, or is to be, packed to the next higher packaging quantity. GS1 Description: An indication from the buyer which allows the supplier to pack, if required, the ordered item to its next higher complete level of packaging.
AS	Available now - scheduled to ship (date) The material is available for shipment and is committed for shipment/delivery at a future date. GS1 Description: Back ordered product (product which has been ordered, was not delivered as scheduled but which the buyer still expects to receive at a later date) is now available and is scheduled for shipment on a specified date.
BK	Back ordered from previous order An order is being held as no material is available to fulfil the requirement. EDIFACT
BP	Shipment partial - back order to follow A portion of the previous order is being held as open, as enough material was not available to fulfil the requirement. GS1 Description: The shipment is incomplete, the missing quantities are to follow.
CC	Shipment complete The quantity dispatched fulfilled the order quantity. GS1 Description: The shipment is complete.
CE	Shipment includes extra items to meet price break The quantity dispatched exceeds the order quantity to accommodate a quantity of scale price model opportunity. GS1 Description: An additional quantity to the quantity ordered has been added for special discounts.
CK	Cancelled from previous order Amount deleted from the earlier schedule. EDIFACT
CM	Shipment complete with additional quantity The quantity dispatched exceeds the ordered quantity. GS1 Description: The shipment is complete and includes an additional quantity.
CN	Next carrier, PVE - (date) Self explanatory. GS1 Description: Item will be shipped on the next available or scheduled carrier.

Used Codes

CP	<p>Shipment partial - considered complete, no backorder The quantity shipped is less than the amount authorized and there is no plan to ship the remaining amount.</p> <p>GS1 Description: Shipment does not fulfil the complete order but should be considered complete. Unshipped items are not considered to be on backorder.</p>
CS	<p>Shipment complete with substitution The quantity and product shipped, though not exactly matching the original order, is compliant with and fulfils the expectation.</p> <p>GS1 Description: Shipment considered complete. One or more items in the order have been substituted by other items.</p>
IC	<p>Item cancelled The material previously ordered is no longer needed.</p> <p>GS1 Description: Item has been cancelled from the order by the buyer or supplier.</p>
IS	<p>Item represents substitution from original order The quantity and product shipped is compliant with the expectation.</p> <p>GS1 Description: Item substitutes another item originally ordered.</p>
OS	<p>Item out of stock because of strike of force majeure Item is not available due to strike or an unforeseeable event.</p>
OW	<p>Item out of stock at wholesaler Item is not available at the distribution point.</p>
PO	<p>Purchase order inquiry - unshipped items only The response includes information concerning all of the articles that were not dispatched and included in the prior inquiry that had been requested by the contact initiator.</p> <p>EDIFACT</p>
PP	<p>Purchase order inquiry - specific items The response includes information concerning a unique sub-set of the total list of articles that the contract initiator had requested information on.</p> <p>EDIFACT</p>
PS	<p>In process - scheduled to ship (date) This amount is being manufactured in anticipation for a possible authorization for shipment.</p> <p>EDIFACT</p>
RA	<p>Item rationed Product is restricted because of limited availability.</p> <p>GS1 Description: Item has been rationed, ordered quantity exceeds rationed quantity.</p>

Used Codes

TW	Item temporarily discontinued by wholesaler Product is, for the time being, not available from the distribution point. GS1 Description: The item has been temporarily removed from the product range of the wholesaler.
US	Pack to closest complete logistic packaging quantity Pack to the closest complete logistic packaging quantity. GS1 Description: An indication from the buyer which allows the supplier to pack, if required, the ordered item to its closest complete level of packaging.
UT	Pack to next lower complete logistic quantity Pack to the next lower complete logistic packaging quantity. GS1 Description: An indication from the buyer which allows the supplier to pack, if required, the ordered item to the next lowest complete logistics packaging.
4233	Marking instructions code Code specifying instructions for marking.
1	Do not mark supplier's company name Packaging should not be marked with supplier's company name.
2	Mark customer's company name Packaging should be marked with customer's company name.
3	Mark customer's references Packaging should be marked with customer's references.
4	Mark additionally customer's article description Packaging should also be marked with customer's article description.
5	Mark exclusively customer's article description Packaging should be marked with customer's article description only.
6	Mark packages dimensions Packaging should be marked with package's dimensions.
7	Mark net weight Packaging should be marked with net weight.
8	Mark gross weight Packaging should be marked with gross weight.
9	Mark tare weight Packaging should be marked with tare weight.
10	Mark batch number Packaging should be marked with batch number.
11	Mark article number customer Packaging should be marked with customer's article number.

Used Codes

12	Mark running number of packages Packaging should be marked with the running number of packages.
13	Mark date of production Packaging should be marked with the date of production.
14	Mark expiry date Packaging should be marked with the expiry date.
15	Mark supplier number Packaging should be marked with the supplier number.
16	Buyer's instructions Markings as specified by the buyer.
17	Supplier's instructions Markings as specified by the seller. GS1 Description: Markings as specified by the supplier.
18	Carrier's instructions Markings as specified by carrier.
19	Legal requirements Markings as specified by law.
20	Industry instructions Markings as specified by industry.
30	Mark serial shipping container code Requests the marking of the serial shipping container code to the transport container or packaging.
32	Mark date of packaging Packaging must be marked with the packaging date. GS1 Note: Replaces GS1 Temporary Code 41E.
33	Mark reference to source entity Packaging must be marked with the reference to source entity. The reference to source identifies that the trade item was derived from.
34	Marked GS1 Global Individual Asset Identifier Indication that the GS1 Global Individual Asset Identifier has been marked on the package. GS1 Note: Replaces GS1 Temporary Code 42G.
35	Marked with a product serial number Indication that the product serial number has been marked on a package.
38	Marked price Indication that the price has been marked on a package. GS1 Note: Replaces GS1 Temporary Code 31E.

Used Codes

39	<p>Marked with Serial Shipping Container Code (SSCC) Indication that the Serial Shipping Container Code has been marked on a package. GS1 Note: Replaces GS1 Temporary Code 33E.</p>
40	<p>Marked with first freezing date Indication that the first freezing date has been marked on the package. GS1 Note: Replaces GS1 Temporary Code 35E.</p>
41	<p>Marked with batch number Indication that the batch number has been marked on a package. GS1 Note: Replaces GS1 Temporary Code 36E.</p>
42	<p>Marked with production date Indication that the production date has been marked on a package. GS1 Note: Replaces GS1 Temporary Code 37E.</p>
43	<p>Marked with expiry date Indication that the expiry date has been marked on a package. GS1 Note: Replaces GS1 Temporary Code 38E.</p>
44	<p>Marked with best before date Indication that the best before date has been marked on a package. GS1 Note: Replaces GS1 Temporary Code 39E.</p>
45	<p>Marked net weight Indication that the net weight has been marked on a package. GS1 Note: Replaces GS1 Temporary Code 40E.</p>
46	<p>Marked with packaging date Indication that the packaging date has been marked on a package. GS1 Note: Replaces GS1 Temporary Code 41E.</p>
47	<p>Marked with GS1 Global Returnable Asset Identifier (GRAI) Indication that the GS1 Global Returnable Asset Identifier (GRAI) has been marked on the package. GS1 Note: Replaces GS1 Temporary Code 41G.</p>
48	<p>Marked with a greeting message Indication that the package has been marked with a greeting message. GS1 Note: Replaces GS1 Temporary Code X27.</p>
49	<p>Price per unit of measure marked on product The price per unit of measure is marked on trade item</p>
31E	<p>Mark price (GS1 Temporary Code) Coded instruction that the price be marked on a package. GS1 Note: Code marked for deletion. Use value 38 instead.</p>
32E	<p>Mark GS1 number (GS1 Temporary Code) Coded instruction that the GS1 number be marked on a package.</p>

Used Codes

33E	Marked with serial shipping container code (GS1 Temporary Code) Indication that the serial shipping container code has been marked on a package. GS1 Note: Code marked for deletion. Use value 39 instead.
34E	Marked with GS1 number (GS1 Temporary Code) Indication that the GS1 number has been marked on a package.
35E	Marked with first freezing date (GS1 Temporary Code) Indication that the first freezing date has been marked on the package. GS1 Note: Code marked for deletion. Use value 40 instead.
36E	Marked with batch number (GS1 Temporary Code) Indication that the batch number has been marked on a package. GS1 Note: Code marked for deletion. Use value 41 instead.
37E	Marked with production/manufacturing date (GS1 Temporary Code) Indication that the production/manufacturing date has been marked on a package. GS1 Note: Code marked for deletion. Use value 42 instead.
38E	Marked with expiry date (GS1 Temporary Code) Indication that the expiry date has been marked on a package. GS1 Note: Code marked for deletion. Use value 43 instead.
39E	Marked with best before date (GS1 Temporary Code) Indication that the best before date has been marked on a package. GS1 Note: Code marked for deletion. Use value 44 instead.
40E	Marked with unit net weight (GS1 Temporary Code) Indication that the net unit weight has been marked on a package. GS1 Note: Code marked for deletion. Use value 45 instead.
41E	Marked with packaging date (GS1 Temporary Code) Indication that the packaging date has been marked on a package. GS1 Note: Code marked for deletion. Use value 46 instead.
41G	Marked with GS1 Global Returnable Asset Identifier (GS1 Temporary Code) Indication that the GS1 Global Returnable Asset Identifier has been marked on the package. GS1 Note: Code marked for deletion. Use value 47 instead.
IEN	Package Identity Number (GS1 Temporary Code) Number uniquely identifying a package.
X26	Not marked with an GS1 code (GS1 Temporary Code) Indication that the package is not marked with an GS1 code.
X27	Marked with a greeting message (GS1 Temporary Code) Package should be marked with greeting message GS1 Note: Code marked for deletion. Use value 48 instead.
X28	GINC (GS1 Temporary Code) Global Identification Number for Consignment

Used Codes

X29	GSIN (GS1 Temporary Code) Global Shipment Identification Number
X3	Marked with use by date (GS1 Temporary Code) Indication that the use by date has been marked on a package.
4277	Payment terms description identifier Identification of the terms of payment between the parties to a transaction (generic term). Notes: 1. Recommend use UN/ECE Recommendation No. 17 Payterms.
1	Draft(s) drawn on issuing bank Draft(s) must be drawn on the issuing bank.
2	Draft(s) drawn on advising bank Draft(s) must be drawn on the advising bank.
3	Draft(s) drawn on reimbursing bank Draft(s) must be drawn on the reimbursing bank.
4	Draft(s) drawn on applicant Draft(s) must be drawn on the applicant.
5	Draft(s) drawn on any other drawee Draft(s) must be drawn on any other drawee.
6	No drafts No drafts required.
ZZZ	Mutually defined (GS1 Temporary Code) A code identifying mutually defined payment terms.
4279	Payment terms type code qualifier Code qualifying the type of payment terms.
1	Basic Payment conditions normally applied.
2	End of month Payments are due at end of month. GS1 Description: Payment terms are at the end of the current month.
3	Fixed date Payments are due on the fixed date specified.
4	Deferred Payments are deferred beyond the normal due date.

Used Codes

5	Discount not applicable Payment terms on which discounts are not applicable. GS1 Description: Discount is not applicable to the payment terms.
6	Mixed Different payment terms negotiated under a documentary credit.
7	Extended Payment is extended beyond the normal due date.
8	Basic discount offered Payment terms reflect the basic offered discount.
9	Proximo Occurring in the next month after present.
10	Instant Payment is due on receipt of invoice.
11	Elective Payment terms to be chosen by buyer (from options separately advised).
12	10 days after end of month Payment due ten days after end of a calendar month.
18	Previously agreed upon Payment terms have been previously agreed upon.
20	Penalty terms Payment terms on which penalties apply. GS1 Description: Penalty terms applied when payer exceeds normal payment terms.
21	Payment by instalment Payment terms are based on instalment payments.
22	Discount Payment terms on which discounts are applicable. GS1 Description: Payment conditions related to discounts for advanced payments.
37	Complete payment Payment must be made for complete value and may not be paid in instalments. EDIFACT
75	Lump sum The payment term requires a lump sum payment.
X10	Discount after deducting freight (GS1 Temporary Code) GS1 Note: Code marked for deletion.

Used Codes

X11	Valuta (GS1 Temporary Code) GS1 Note: Code marked for deletion.
ZZZ	Mutually defined A code assigned within a code list to be used on an interim basis and as defined among trading partners until a precise code can be assigned to the code list.
4295	Change reason description code Code specifying the reason for a change.
AA	Member attribute change An attribute of a member of a group has changed.
AC	Member category change The member or benefits category has changed.
AJT	Adjustment (GS1 Temporary Code) Code indicating that an adjustment has taken place.
AQ	Alternate quantity and unit of measurement Change is due to an alternate quantity and unit of measurement. GS1 Description: Code indicating an alternate quantity and unit of measure than that was previously agreed.
AR	Article out of assortment for particular company Item normally part of a suppliers standard assortment but is unavailable for a specific buyer due to legal or commercial reasons.
ARP	Article to be published (GS1 Temporary Code) The article has to be published.
AS	Article out of assortment Article normally part of a standard assortment is unavailable.
AT	Item not ordered Code indicating the item or product was not ordered.
AU	No delivery due to outstanding payments Delivery of an item was stopped due to outstanding deliveries which have not yet been paid.
AUE	Article code unknown (GS1 Temporary Code) Item identification code (GTIN article number) is unknown. GS1 Note: Code marked for deletion. Use value BJ instead.
AV	Out of inventory Item is out of inventory.

Used Codes

AY	<p>Sale location different Sold in a different sales location. GS1 Description: The reason for a different price is a different sale location and a different type of sale location, for example, a duty paid shop or a duty free shop.</p>
BA	<p>Damaged Goods CA change resulting from damaged goods. EDIFACT</p>
BB	<p>Transport means technical failure Transport means had a technical failure, e.g. transport means could not be unloaded or did not comply with hygienic requirements.</p>
BC	<p>Equipment technical failure Equipment had a technical failure, e.g. equipment was damaged or wrong.</p>
BE	<p>Goods technical failure Goods had a technical failure, e.g. instability, overhang, transportation lock or damage.</p>
BF	<p>Spoilage of goods A change resulting from the spoilage of goods.</p>
BG	<p>Grade difference out of tolerance level The change is due to a variation in the grade of the product outside the tolerance level allowed in an agreement.</p>
BH	<p>Batch number difference The batch number printed on the product received is different to the batch number specified in the despatch advice message.</p>
BI	<p>Expiry date difference The expiry date printed on the product received is different from the expiry date specified in the despatch advice message. GS1 Note: Replaces GS1 Temporary Code X40.</p>
BJ	<p>Item identification code unknown The item identification code is unknown. GS1 Note: Replaces GS1 Temporary Code AUE.</p>
BK	<p>Barcode not readable Barcode is not readable by a barcode scanning device. GS1 Note: Replaces GS1 Temporary Code BN_OLD.</p>
BL	<p>Item represents substitution from original order Code indicating the item or product is a substitute of the item or product originally ordered. GS1 Note: Replaces GS1 Temporary Code IS.</p>
BM	<p>Minimum/maximum product durability date unacceptable Code indicating that the minimum durability date (e.g. best before date) and/or maximum durability date (e.g. expiry date) of a product are not acceptable. GS1 Note: Replaces GS1 Temporary Code PE.</p>

Used Codes

BN	Temperature outside agreed range The temperature is or has been outside the agreed range. GS1 Note: Replaces GS1 Temporary Code X32.
BN_OLD	Bar code not readable (GS1 Temporary Code) Bar code is not readable for some reason (e.g. poor print quality) by a bar code scanning device. GS1 Note: Code marked for deletion. Use value BK instead.
BO	Delivered but not advised Shipment or goods have been delivered without any advance notification of delivery. GS1 Note: Replaces GS1 Temporary Code X33.
BP	Short shipped The quantity of goods received is smaller than advised. GS1 Note: Replaces GS1 Temporary Code X34.
BR	Item withdrawn The item has been withdrawn. GS1 Note: Replaces GS1 Temporary Code X35.
BS	SSCC difference The logistic unit is identified by another Serial Shipping Container Code (SSCC) than the one announced in the despatch advice. GS1 Note: Replaces GS1 Temporary Code X37.
BT	SSCC missing The logistic unit is missing its Serial Shipping Container code (SSCC). GS1 Note: Replaces GS1 Temporary Code X38.
BU	Best before date(s) difference The best before date(s) deviate(s) from those announced in the despatch advice. GS1 Note: Replaces GS1 Temporary Code X39.
BV	Weight difference More or less weight was received than announced in the despatch advice. GS1 Note: Replaces GS1 Temporary Code X41.
BW	Quantity difference More or less units were received than announced in the despatch advice.
BX	Delivered too late Delivered but at a later date than the delivery date under the agreed conditions or stipulated in the preceding message. GS1 Note: Replaces GS1 Temporary Code X43.
IS	Item represents substitution from original order (GS1 Temporary Code) Code indicating the item or product is a substitute of the item or product originally ordered. GS1 Note: Code marked for deletion. Use value BL instead.

Used Codes

PC	Pack difference Self-explanatory. GS1 Description: The packaging of the product has changed.
PE	Minimum/maximum product durability date unacceptable (GS1 Temporary Code) Code indicating that the minimum durability date (e.g. best before date) or maximum durability date (e.g. expiry date) of a product are not acceptable. GS1 Note: Code marked for deletion. Use value BM instead.
PS	Product/services ID change The product/services identification has changed.
QT	Quantity price break The quantity price break has changed. GS1 Description: Additional quantity shipped to meet special discount conditions.
UM	Unit of measure difference The change is due to a difference in the unit of measure. GS1 Description: The unit of measure for the product shipped is different to the unit of measure for the product ordered.
WQ	Over shipped A shipped quantity greater than the ordered or invoiced quantity.
WR	Temporarily unavailable Product is temporarily unavailable.
WT	Excluded from the promotion activity Product is not included in the promotion activity.
WU	Committed purchase quantity exceeded The committed purchase quantity has been exceeded.
WV	Committed purchase quantity not ordered The committed purchase quantity has not been ordered.
X29	Government price charge (GS1 Temporary Code) Reason for price charge is due to government action.
X32	Receipt temperature outside agreed range (GS1 Temporary Code) The temperature at which the goods are received is outside the agreed range. GS1 Note: Code marked for deletion. Use value BN instead.
X33	Delivered but not advised (GS1 Temporary Code) Shipment or goods have been delivered without any advance notification of delivery. GS1 Note: Code marked for deletion. Use value BO instead.

Used Codes

X34	Missing (GS1 Temporary Code) The quantity of goods received is smaller than advised. GS1 Note: Code marked for deletion. Use value BP instead.
X35	Article withdrawn (GS1 Temporary Code) The article has been withdrawn GS1 Note: Code marked for deletion. Use value BR instead.
X36	Best before date out of chronological order (GS1 Temporary Code) Goods have a best before date which is out of chronological order.
X37	Wrong SSCC (GS1 Temporary Code) The logistic unit is identified by another SSCC than the one announced in the despatch advice. GS1 Note: Code marked for deletion. Use value BS instead.
X38	SSCC missing (GS1 Temporary Code) The logistic unit is missing its SSCC. GS1 Note: Code marked for deletion. Use value BT instead.
X39	Wrong best before date(s) (GS1 Temporary Code) The best before date(s) deviates from the one announced in the despatch advice. GS1 Note: Code marked for deletion. Use value BU instead.
X40	Wrong expiry date(s) (GS1 Temporary Code) The expiry date(s) deviates from the one announced in the despatch advice. GS1 Note: Code marked for deletion. Use value BI instead.
X41	Different weight (GS1 Temporary Code) More or less weight was received than expected with regard of what was announced in the despatch advice. GS1 Note: Code marked for deletion. Use value BV instead.
X42	Over-shipped (GS1 Temporary Code) An excess quantity of goods was received in a shipment with regard of what was expected in the despatch advice. GS1 Note: Code marked for deletion. Use value WQ instead.
X43	Delivered too late (GS1 Temporary Code) Delivered but at a later date than the delivery date under the agreed conditions or stipulated in the preceding message GS1 Note: Code marked for deletion. Use value BX instead.
X44	GS1 bar code label missing (GS1 Temporary Code) The GS1 bar code label is missing
4343	Response type code Code specifying the type of acknowledgment required or transmitted.
AB	Message acknowledgement Indicates that an acknowledgement relating to receipt of message is required.

Used Codes

NA	No acknowledgement needed Specifies that no acknowledgement is needed in response to this message.
4347	Product identifier code qualifier Code qualifying the product identifier.
1	Additional identification Information which specifies and qualifies product identifications.
4	Substituted for The given item number is the number of the original product substituted by another.
5	Product identification The item number is for product identification.
4431	Payment guarantee means code Code specifying the means of payment guarantee.
10	Bank guarantee A bank has agreed to stand as guarantor to ensure that payment is made.
11	Public authority guarantee A public authority has agreed to stand as guarantor to ensure that payment is made.
12	Third party guarantee The party who has agreed to stand as guarantor to ensure that payment is made is neither the payee nor the payor.
13	Standby letter of credit The guarantee of payment is in the form of a standby letter of credit.
14	No guarantee No guarantee of payment has been made or is available.
20	Goods as security The payor has provided possession of, or title in goods, as security against payment. GS1 Description: Title to the goods is retained by the supplier until payment is received.
21	Business as security The payor has provided title in, or a lien over a business whose assets may be sold or sequestered, as security against payment. GS1 Description: Business provided as security.

Used Codes

23	Warrant or similar (warehouse receipts) The payor has provided a warrant or warehouse receipts for goods or property to be held or used as security against payment. GS1 Description: Warrent or similar provided as security.
41	Book guarantee/book bond Self explanatory. GS1 Description: Book guarantee/book bond provided as security.
44	Group guarantee Self explanatory. Notes: This code value will be removed effective with directory D.04B. GS1 Description: Group guarantee provided as security.
45	Insurance certificate A certificate of insurance has been provided as a guarantee of eventual payment.
4435	Payment channel code Code specifying the payment channel.
1	Ordinary post The payment shall be/has been made via ordinary post.
2	Air mail The payment shall be/has been made via air mail.
3	Telegraph The payment shall be/has been made via telegraph.
4	Telex The payment shall be/has been made via telex.
5	S.W.I.F.T. Society for Worldwide Interbank Financial Telecommunications s.c.
6	Other transmission networks The payment shall be/has been made via other transmission networks.
7	Networks not defined The payment shall be/has been made via not defined networks.
8	Fedwire The payment shall be/has been made via Fedwire.
9	Personal (face-to-face) Indicates that payment should be made by the bank to the beneficiary or his identified agent, in person.

Used Codes

10	Registered air mail The payment shall be/has been made via registered air mail.
11	Registered mail The payment shall be/has been made via registered mail.
14	National ACH Nation wide clearing house for automated payment.
62	Set-off by reciprocal credits (GS1 Temporary Code) GS1 Note: Code marked for deletion. Use DE 4461 value 97 instead.
4439	Payment conditions code Code specifying the payment conditions.
1	Direct payment An assigned invoice has been paid by the buyer to the factor.
10	Irrevocable documentary credit Written undertaking by a bank to pay a seller against stipulated documents that cannot be amended or cancelled without the consent of all parties involved. GS1 Description: Payment is made using an irrevocable documentary credit.
15	Irrevocable letter of credit-confirmed Letter of credit that cannot be cancelled or amended without agreement by all the parties involved, and carries the endorsement of both the issuing bank and its correspondent, guaranteeing payment of all drafts written against. GS1 Description: Payment is made using an irrevocable letter of credit confirmed.
17	Revocable letter of credit Letter of credit that can be cancelled or amended at any time by the issuing bank. GS1 Description: Payment is made using an revocable letter of credit.
19	Irrevocable letter of credit unconfirmed Letter of credit that cannot be cancelled or amended before a specific date without agreement by all the parties involved, and carries no guarantee that a correspondent will honour drafts presented for payment. GS1 Description: Payment is made using an irrevocable letter of credit unconfirmed.
30	Other collection Self explanatory. Notes: This code value will be removed effective with directory D.04B.
34	Seller to advise buyer Payment conditions to be advised by the seller to the buyer.

Used Codes

35	Documents through banks Also known as 'documents against presentation', the documents are sent to a bank, and the buyer obtains the documents by paying the invoice amount to the bank. GS1 Description: Payment is made using documents passed through the banks.
65	Reverse factoring Condition of payment to suppliers in which a third party (for example, a bank) manages the payments that one company has to make to its suppliers.
OA	Open account (GS1 Temporary Code) Open account payment terms.
4441	Free text value code Code specifying free form text.
78E	Proof Of Delivery (GS1 Permanent Code) The mentioned URL refers to a Proof of Delivery document. This Code value can be used if DE 4451 of the FTX segment is ZXL.
4451	Text subject code qualifier Code qualifying the subject of the text.
1E	Additional product information address (GS1 Temporary Code) Address at which additional information on the product can be found. GS1 Note: Code marked for deletion. Use value BAI instead.
2E	VAT exemption (GS1 Temporary Code) VAT exemption reason in clear text. GS1 Note: Code marked for deletion. Use value BAQ instead.
3E	Tracking URL (GS1 Temporary Code) The internet link (URL) to track the delivery of a specific package or consignment.
AAA	Goods description [7002] Plain language description of the nature of the goods sufficient to identify them at the level required for banking, Customs, statistical or transport purposes, avoiding unnecessary detail (Generic term).
AAB	Terms of payments [4276] Conditions of payment between the parties to a transaction (generic term).
AAC	Dangerous goods additional information Additional information concerning dangerous goods.

Used Codes

AAD	Dangerous goods, technical name Proper shipping name, supplemented as necessary with the correct technical name, by which a dangerous substance or article may be correctly identified or which is sufficiently informative to permit identification by reference to generally available literature.
AAG	Party instructions Indicates that the segment contains instructions to be passed on to the identified party.
AAI	General information The text contains general information.
AAK	Price conditions Information on the price conditions that are expected or given.
AAM	Equipment re-usage restrictions Technical or commercial reasons why a piece of equipment may not be re-used after the current transport terminates.
AAN	Handling restriction Restrictions in handling depending on the technical characteristics of the piece of equipment or on the nature of the goods.
AAO	Error description (free text) Error described by a free text.
AAR	Terms of delivery (4053) Free text of the non Incoterms terms of delivery. For Incoterms, use: 4053.
AAW	Letter of credit information Information pertaining to the letter of credit.
AAZ	Additional export information The text contains additional export information.
ABN	Accounting information Self explanatory. GS1 Description: Free text information regarding account.
ABO	Discrepancy information Free text or coded information to indicate a specific discrepancy.
ABU	Deferred payment termed additional Additional terms concerning deferred payment.
ACB	Additional information The text contains additional information.
ACD	Reason Reason for a request or response.

Used Codes

ACE	Dispute A notice, usually from buyer to seller, that something was found wrong with goods delivered or the services rendered, or with the related invoice.
ACF	Additional attribute information The text refers to information about an additional attribute not otherwise specified.
ACL	Quality Statement Code A statement on the quality of an object.
ADK	Promotion information The text contains information about a promotion.
ADL	Meter condition Description of the condition of a meter.
ADM	Meter reading information Information related to a particular reading of a meter.
ADS	Booked item information (SWIFT Code) Information pertaining to a booked item. GS1 Description: Information related to an item booked onto a financial account.
AEI	Instructions to the applicant Instructions given to the applicant.
AFF	Batch code structure A description of the structure of a batch code.
AFG	Product application A general description of the application of a product.
AGW	Location Description of a location.
AGZ	Marketing activities Information concerning marketing activities.
AIP	Question A free text question.
AIQ	Party information Free text information related to a party.
AIX	Warranty terms Text describing the terms of warranty which apply to a product or service.
ALL	All documents The note implies to all documents.

Used Codes

BAI	Additional product information address Address at which additional information on the product can be found. GS1 Note: Replaces GS1 Temporary Code 1E.
BAJ	Information to be printed on despatch advice Specification of free text information which is to be printed on a despatch advice. GS1 Note: Replaces GS1 Temporary Code DSI.
BAK	Missing goods remarks Remarks concerning missing goods. GS1 Note: Replaces GS1 Temporary Code MIS.
BAL	Non-acceptance information Information related to the non-acceptance of an order, goods or a consignment. GS1 Note: Replaces GS1 Temporary Code NAI.
BAM	Returns information Information related to the return of items. GS1 Note: Replaces GS1 Temporary Code RTI.
BAN	Sub-line item Note contains information related to sub-line item data. GS1 Note: Replaces GS1 Temporary Code SID.
BAO	Test information Information of a test. GS1 Note: Replaces GS1 Temporary Code TIN.
BAP	External link The external link to a digital document (e.g.: URL) GS1 Note: Replaces GS1 Temporary Code ZXL.
BAQ	VAT exemption reason The reason for Value Added Tax exemption. GS1 Note: Replaces GS1 Temporary Code 2E.
BLR	Transport document remarks Remarks concerning the complete consignment to be printed on the bill of lading.
BLV	B2C marketing information, short description Consumer marketing information, short description.
BLW	B2B marketing information, long description Trading partner marketing information, long description.
BLX	B2C marketing information, long description Consumer marketing information, long description.

Used Codes

BLY	<p>Product ingredients</p> <p>Information on the ingredient make up of the product.</p> <p>Information on the constituent ingredient make up of the product specified as one string.</p> <p>Example: FTX+ING+1+ +Tomato puree (54%), water, onions (9%), sunflower seed oil' FTX+ING+1+ +(cold pressed, untempered, unrefined) (10%), corn syrup (2%), soy protein (12%):++EN'</p>
CHG	<p>Change information</p> <p>Note contains change information.</p>
CIP	<p>Customs clearance instruction import</p> <p>Any coded or clear instruction agreed by customer and carrier regarding the import declaration of the goods.</p>
CLR	<p>Loading remarks</p> <p>Instructions concerning the loading of the container.</p>
CUS	<p>Customs declaration information</p> <p>Note contains customs declaration information.</p>
DAR	<p>Damage remarks</p> <p>Remarks concerning damage on the cargo.</p>
DEL	<p>Delivery information</p> <p>Information about delivery.</p>
DIN	<p>Delivery instructions</p> <p>Instructions regarding the delivery of the cargo.</p>
DSI	<p>Information to be printed on despatch advice (GS1 Temporary Code)</p> <p>Specification of free text information which is to be printed on a despatch advice.</p> <p>GS1 Note: Code marked for deletion. Use value BAJ instead.</p>
DUT	<p>Duty declaration</p> <p>The text contains a statement constituting a duty declaration.</p>
GEN	<p>Entire transaction set</p> <p>Note is general in nature, applies to entire transaction segment.</p>
HAN	<p>Handling instructions</p> <p>[4078] Instructions on how specified goods, packages or containers should be handled.</p>
HAZ	<p>Hazard information</p> <p>Information pertaining to a hazard.</p>
IIN	<p>Insurance instructions</p> <p>Instructions regarding the cargo insurance.</p>

Used Codes

INS	Insurance information Specific note contains insurance information.
INV	Invoice instruction Note contains invoice instructions.
ITS	Testing instructions Instructions regarding the testing that is required to be carried out on the items in the transaction.
LIN	Line item Note contains line item information.
LOI	Loading instruction Instructions where specified packages or containers are to be loaded on a means of transport.
MIS	Missing goods remarks (GS1 Temporary Code) Remarks concerning missing goods. GS1 Note: Code marked for deletion. Use value BAK instead.
MKS	Additional marks/numbers information Additional information regarding the marks and numbers.
NAI	Non-acceptance information (GS1 Temporary Code) Information related to the non-acceptance of an order, goods or a consignment. GS1 Note: Code marked for deletion. Use value BAL instead.
ORI	Order instruction Free text contains order instructions.
OSI	Other service information General information created by the sender of general or specific value.
PAC	Packing/marking information Information regarding the packaging and/or marking of goods.
PAY	Payables information Note contains payables information.
PKG	Packaging information Note contains packaging information. GS1 Description: Note contains packaging instructions.
PMD	Payment detail/remittance information The free text contains payment details.
PMT	Payment information Note contains payments information.
PRD	Product information The text contains product information.

Used Codes

PRF	Price calculation formula Additional information regarding the price formula used for calculating the item price.
PRI	Priority information Note contains priority information.
PUR	Purchasing information Note contains purchasing information.
QQD	Quality demands/requirements Specification of the quality/performance expectations or standards to which the items must conform.
QUT	Quotation instruction/information Note contains quotation information.
REG	Regulatory information The free text contains information for regulatory authority.
RET	Return to origin information Free text information on an IATA Air Waybill to indicate consignment returned because of non delivery.
REV	Receivables The text contains receivables information.
RQR	Requested routes/routing instructions [3074] Names of places via which the consignor requests a consignment to be routed.
RQT	Tariffs and route requested [4120] Stipulation of the tariffs to be applied showing, where applicable, special-agreement numbers or references; indication of routes by frontier points or by frontier stations and, when necessary, by transit stations between.
RTI	Returns information (GS1 Temporary Code) Information related to the return of goods. GS1 Note: Code marked for deletion. Use value BAM instead.
SAF	Safety information The text contains safety information.
SIC	Sender's instruction to carrier [4284] Instructions given and declarations made by the sender to the carrier concerning Customs, insurance, and other formalities.
SID	Sub line item (GS1 Temporary Code) Note contains information related to sub line item data. GS1 Note: Code marked for deletion. Use value BAN instead.
SIN	Special instructions Special instructions like licence no, high value, handle with care, glass.

Used Codes

SPH	Special handling Note contains special handling information.
SSR	Special service request Request for a special service concerning the transport of the goods.
SUR	Supplier remarks Remarks from or for a supplier of goods or services.
TIN	Test information (GS1 Temporary Code) Information related to a test which will be, or has been, carried out. GS1 Note: Code marked for deletion. Use value BAO instead.
TRA	Transportation information General information regarding the transport of the cargo.
TXD	Tax declaration The text contains a statement constituting a tax declaration.
WHI	Warehouse instruction/information Note contains warehouse information.
XYZ	No partial delivery (GS1 Temporary Code) The goods that are not delivered have to be re-ordered by the buyer. Supplier only delivers the goods they have in stock at that moment. One order leads to one delivery.
ZXL	External link (GS1 Temporary code) The external link to a digital document (e.g.: URL) GS1 Note 1: This Code value can be used if no EFI segment is available. If the type of the referenced document (e.g. proof-of-delivery.pdf) can be identified by a code value of DE 1001, this code value should be used to fill DE 4441. (e.g. 78E), DE 3055 = 9. GS1 Note 2: Code marked for deletion. Use value BAP instead.
ZYZ	Partial delivery allowed (GS1 Temporary Code) The supplier keeps delivering until the entire order is fulfilled. One order can lead to many deliveries. The buyer doesn't need to place a new order; they just waits for the other goods to be delivered.
ZZZ	Mutually defined Note contains information mutually defined by trading partners.
4453	Free text function code Code specifying the function of free text.
1	Text for subsequent use The occurrence of this text does not affect message processing.
4461	Payment means code Code identifying a means of payment.

Used Codes

3	Automated clearing house debit A debit transaction made through the automated clearing house system.
8	Hold Indicates that the bank should hold the payment for collection by the beneficiary or other instructions.
10	In cash Payment by currency (including bills and coins) in circulation, including checking account deposits.
15	Bookentry credit A credit transaction, initiated from the buyer's account to the seller's account at the same financial institution. GS1 Description: A credit transaction, initiated from the buyer's account to the seller's account at the same financial institution.
16	Bookentry debit A debit transaction initiated from the seller's account to the buyer's account at the same financial institution.
20	Cheque Self explanatory.
21	Banker's draft Issue of a banker's draft in payment of the funds.
23	Bank cheque (issued by a banking or similar establishment) Payment by a pre-printed form, which has been completed by a financial institution, on which instructions are given to an account holder (a bank or building society) to pay a stated sum to a named recipient.
24	Bill of exchange awaiting acceptance Bill drawn by the creditor on the debtor but not yet accepted by the debtor.
25	Certified cheque Payment by a pre-printed form stamped with the paying bank's certification on which instructions are given to an account holder (a bank or building society) to pay a stated sum to a named recipient .
26	Local cheque Indicates that the cheque is given local to the recipient.
27	ACH demand corporate trade payment (CTP) debit A debit transaction made through the ACH system to a demand deposit account using the CTP payment format.
28	ACH demand corporate trade exchange (CTX) credit A credit transaction made through the ACH system to a demand deposit account using the CTX payment format.
30	Credit transfer Payment by credit movement of funds from one account to another.

Used Codes

31	Debit transfer Payment by debit movement of funds from one account to another.
42	Payment to bank account
49	Direct debit The amount is to be, or has been, directly debited to the customer's bank account.
50	Payment by postgiro Payment is made by postal giro.
54	Credit card Payment made by means of credit card. GS1 Note: Replaces GS1 Temporary Code 11E.
55	Debit card Payment made by means of debit card. GS1 Note: Replaces GS1 Temporary Code 12E.
56	Bankgiro Payment will be, or has been, made by bankgiro. GS1 Note: Replaces GS1 Temporary Code 14E.
60	Promissory note Payment is made by promissory note.
70	Bill drawn by the creditor on the debtor Bill drawn by the creditor on the debtor.
74	Bill drawn by the creditor on a bank Bill drawn by the creditor on a bank.
97	Clearing between partners Amounts which two partners owe to each other to be compensated in order to avoid useless payments.
10E	Payment terms defined in the Commercial Account Summary (GS1 Temporary Code) Code indicating that the payment terms will be defined in a later Commercial Account Summary (COACSU) message.
11E	Credit card (GS1 Temporary Code) Payment made by means of credit card. GS1 Note: Code marked for deletion. Use value 54 instead.
12E	Debit card (GS1 Temporary Code) Payment made by means of debit card. GS1 Note: Code marked for deletion. Use value 55 instead.
13E	Payment terms defined in consolidated invoice (GS1 Temporary Code) Special conditions where the payment terms are specified in a consolidated invoice.

Used Codes

14E	Payment by bankgiro (GS1 Temporary Code) Payment will be, or has been, made by bankgiro. GS1 Note: Code marked for deletion. Use value 56 instead.
4465	Adjustment reason description code Code specifying the adjustment reason.
1	Agreed settlement Self explanatory. GS1 Description: Adjustment has been made as part of an agreed settlement.
2	Below specification goods Goods of inferior quality.
3	Damaged goods Self explanatory. GS1 Description: Adjustment has been made because of damaged goods.
4	Short delivery Self explanatory. GS1 Description: Adjustment has been made to take into account short delivery.
5	Price query Self explanatory. GS1 Description: Adjustment has been made to take into account a price query.
6	Proof of delivery required The buyer requires that proof of delivery be made before payment. GS1 Description: Adjustment because no proof of delivery was available.
7	Payment on account Buyer is to make payment later. GS1 Description: Adjustment has been made because payment is on account.
8	Returnable container charge included Adjustment made to deduct the returnable container charge. GS1 Description: Adjustment has been made because of an included returnable container charge.
9	Invoice error Invoice not in accordance with the order. GS1 Description: Adjustment has been made to take into account invoice error.
14	Wrong delivery Delivery not according to specifications.

Used Codes

16	Goods partly returned Goods partly returned.
17	Transport damage Goods damaged in transit.
18	Goods on consignment Buyer does not accept invoice(s) charge as it relates to goods where the ownership remains with the seller until sold.
19	Trade discount Trade discount deducted from payment.
20	Discount for late delivery Penalty amount deducted for later delivery.
21	Advertising costs Advertising costs deducted from payment.
26	Taxes Taxes deducted from payment.
32	Goods not delivered Buyer has not received the goods.
35	Goods returned Buyer returned the goods to seller.
38	Deducted bonus Buyer has/will deduct a bonus he is entitled to from payment.
40	Deducted freight costs Buyer has/will deduct freight costs from the payment
52	Wrong invoice Invoice issued to wrong party.
56	Incorrect discount Buyer states that calculated discount on the invoice(s) is wrongly calculated.
57	Price change Price has been changed.
64	Expecting new terms Buyer expects that seller revises the terms of payment of an invoice.
66	Cash discount An adjustment has been made due to the application of a cash discount.
67	Delcredere costs Costs deducted from a total amount to pay for the services of central payment.
68	Early payment allowance adjustment Adjustment results from the application of an early payment allowance.

Used Codes

69	<p>Incorrect due date for monetary amount Adjustment has been made because an incorrect due date was referred to with regard to the monetary amount.</p>
70	<p>Wrong monetary amount resulting from incorrect free goods quantity Adjustment has been made because of a wrong monetary amount resulting from an incorrect free goods quantity.</p>
71	<p>Rack or shelf replenishment service by a supplier Adjustment due to the replenishment of the racks or shelves by a supplier.</p>
72	<p>Temporary special promotion Adjustment due to a temporary special promotion. GS1 Note: Replaces GS1 Temporary Code 37E.</p>
73	<p>Difference in tax rate Adjustment due to a difference in tax rate.</p>
74	<p>Quantity discount Adjustment due to a quantity discount. GS1 Description: Quantity discount deducted from payment, when a purchase quantity threshold has been met or exceeded.</p>
75	<p>Promotion discount Adjustment due to a promotion discount.</p>
77	<p>Pricing discount An adjustment has been made due to the application of a pricing discount. EDIFACT</p>
79	<p>Sundry discount An adjustment has been made due to the application of a sundry discount. EDIFACT</p>
90	<p>Treasury management service charge Charge for the service of treasury management. This code is used if service provider responsible for treasury management is deducting the invoice by own service charge.</p>
98	<p>Incorrect references Adjustment has taken place because of incorrect references. GS1 Note: Replaces GS1 Temporary Code 10E.</p>
99	<p>Incorrect identification of the buyer Adjustment has taken place because of incorrect identification of the buyer. GS1 Note: Replaces GS1 Temporary Code 12E.</p>
100	<p>Incorrect product identification Adjustment has taken place because of incorrect product identification. GS1 Note: Replaces GS1 Temporary Code 13E.</p>

Used Codes

101	New employee The reason for the adjustment is a new employee. GS1 Note: Replaces GS1 Temporary Code 19E.
102	Employee retirement The reason for the adjustment is the retirement of an employee. GS1 Note: Replaces GS1 Temporary Code 20E.
103	Salary change The reason for the adjustment is a salary change. GS1 Note: Replaces GS1 Temporary Code 21E.
104	Parental leave The reason for the adjustment is a parental leave. GS1 Note: Replaces GS1 Temporary Code 22E.
10E	Incorrect references (GS1 Temporary Code) Adjustment has taken place because of incorrect references. GS1 Note: Code marked for deletion. Use value 98 instead.
11E	Incorrect charge (GS1 Temporary Code) Adjustment has taken place because of an incorrect charge.
12E	Incorrect identification of the buyer (GS1 Temporary Code) Adjustment has taken place because of incorrect identification of the buyer. GS1 Note: Code marked for deletion. Use value 99 instead.
13E	Incorrect product identification (GS1 Temporary Code) Adjustment has taken place because of incorrect product identification.
19E	New employee (GS1 Temporary Code) The reason of the adjustment is a new employee. GS1 Note: Code marked for deletion. Use value 101 instead.
20E	Employee retirement (GS1 Temporary Code) The reason of the adjustment is a retiring of the employee. GS1 Note: Code marked for deletion. Use value 102 instead.
21E	Salary change (GS1 Temporary Code) The reason of the adjustment is a salary change. GS1 Note: Code marked for deletion. Use value 103 instead.
22E	Maternity licence (GS1 Temporary Code) The reason for the adjustment is a maternity licence. GS1 Note: Code marked for deletion. Use value 104 instead.
23E	Job accident (GS1 Temporary Code) An adjustment is due to a job accident.
24E	No exceptional situation (GS1 Temporary Code) There are no exceptional situations.
25E	Temporary suspension of the contract (GS1 Temporary Code) When the contract is suspended, there are no contributions.

Used Codes

26E	Employee incapacity (GS1 Temporary Code) The employee's professional incapacity.
27E	Holiday (GS1 Temporary Code) An adjustment is due to holidays.
28E	Voluntary pension (GS1 Temporary Code) Voluntary pension amount.
29E	Change in salary (GS1 Temporary Code) A contribution change according to the salary.
30E	Special tariff (GS1 Temporary Code) Special tariff given.
31E	Various work places (GS1 Temporary Code) Person working in various places.
37E	Extraordinary promotion services (GS1 Temporary Code) Extraordinary, not permanent promotion services. GS1 Note: Code marked for deletion. Use value 72 instead.
ZZZ	Mutually defined A code assigned within a code list to be used on an interim basis and as defined among trading partners until a precise code can be assigned to the code list.
4471	Settlement means code Code specifying the means of settlement.
1	Bill back Refers to a charge or allowance for the buyer and the buyer will bill back the seller.
2	Off invoice The allowance or charge is being deducted from the invoice. GS1 Description: The allowance or charge is being deducted from the face of the document.
3	Vendor check/cheque to customer An allowance will be given to a customer from the supplier in the form of a check.
4	Credit customer account An allowance will be processed for the customer by giving a credit to their account.
5	Charge to be paid by vendor A charge whose payment will be made by the vendor.
6	Charge to be paid by customer A charge whose payment will be made by the customer.

Used Codes

13	All charges borne by payee All charges are to be borne by the funds receiver. GS1 Description: All charges are to be borne by the beneficiary.
14	Each pay own cost Each party are to be responsible for its own charges.
15	All charges borne by payor All charges are to be borne by the funds sender. GS1 Description: All the charges are to be borne by the ordering customer.
38	Item accruals Expenses related to an item for which invoices have not been received yet at the end of the current accounting period.
39	Vendor accruals Expenses related to a vendor for which invoices have not been received yet at the end of the current accounting period.
5025	Monetary amount type code qualifier Code qualifying the type of monetary amount.
1	VAT, 1st value First VAT value if, for the same rate of VAT, there are 1 to 3 different ways to set this value.
5	Adjusted amount The amount specified is the adjusted amount.
7	Agreed charge Charges which parties agreed upon.
8	Allowance or charge amount [5422] Total amount of allowance or charge.
9	Amount due/amount payable Amount to be paid.
11	Amount paid Amount that has been paid.
12	Amount remitted Amount which was remitted (see remittance advice).
13	Amount subject to total monetary discount The amount is subject to a total monetary discount.

Used Codes

21	Cash discount Cash discount given by the seller to the buyer. GS1 Description: Cash discount given by the seller to the buyer where payment is made in advance of receipt of goods.
22	Cash on delivery amount Amount to be collected by carrier upon delivery of goods. This amount represents approximately the value of the goods.
23	Charge amount The amount of money charged for the provision of a service or product.
25	Charge/allowance basis The amount specified is the basis for calculation of charges/allowance.
36	Converted amount The amount is converted from another currency.
38	Invoice item amount (5068) Total sum charged in respect of a single Invoice item in accordance with the terms of delivery.
39	Invoice total amount [5444] Total sum charged in respect of one or more Invoices in accordance with the terms of delivery.
40	Customs value (5032) Value declared for Customs purposes on those goods in a consignment which are subject to the same Customs procedure, and have the same tariff/statistical heading, country information and duty regime.
43	Declared total Customs value [5070] Total value declared for Customs purposes of all goods in a consignment, whether or not they are subject to the same Customs procedure, or have the same tariff/statistical heading, country information, and duty regime.
44	Declared value for carriage (5036) Value, declared by the shipper or his agent solely for the purpose of varying the carrier's level of liability from that provided in the contract of carriage, in case of loss or damage to goods or delayed delivery.
48	Deposit total The whole amount of money that one entrusts for safekeeping.
50	Disbursements Amount of disbursements to be collected by the carrier according to the order given by the shipper.
51	Disbursements fee Fee charged for the collection of disbursements.

Used Codes

52	Discount amount The amount specified is the discount amount.
53	Discount amount due The amount of discount that is due. GS1 Description: The amount due for a discount.
55	Duty amount The amount of duty. GS1 Description: The amount due for a duty.
56	Duty/tax/fee basis amount The amount specified is the basis for duty/tax or fee.
57	Equivalent amount This amount is equivalent to the amount to be transferred, but in another currency.
60	Final (posted) amount The amount posted to an account, finally, after charges/allowances.
64	Freight charge Amount to be paid for moving goods, by whatever means, from one place to another, inclusive discounts, allowances, rebates, adjustment factors and additional cost relating to freight costs (UN/ECE Recommendation no 23).
74	Amount to be paid in advance Amount which is to be paid before goods are delivered or the service is rendered.
75	Registered capital Registered amount of equity of a company.
77	Invoice amount [5068] Total sum charged in respect of a single Invoice in accordance with the terms of delivery.
79	Total line items amount The sum of all the line item amounts.
81	Loading and handling cost Cost incurred by loading and handling.
83	Lumpsum An agreed sum of money, which is paid in full at one time. This term is often used in connection with charter parties.
86	Message total monetary amount The total of all monetary amounts contained within the message.
97	Offer amount [5210] Total amount of an offer.

Used Codes

98	Original amount Original amount, without charges, allowances or adjustment.
103	Other deductible charges Other charges deducted from the total invoice value.
106	Packing cost Cost for packing concerning labour and/or material.
109	Payment discount amount Amount subject to payment discount.
113	Prepaid amount (5302) Amount which has been prepaid in advance.
119	Received amount The amount is what the bank received, and the one before charges/allowances.
124	Tax amount Tax imposed by government or other official authority related to the weight/ volume charge or valuation charge.
125	Taxable amount Amount on which a tax has to be applied. GS1 Description: The monetary amount liable to tax.
126	To collect Amount that has to be collected.
128	Total amount The amount specified is the total amount.
129	Total amount subject to payment discount Part of the invoice amount which is subject to payment discount.
130	Total charge due Total amount of charges payable to the carrier.
131	Total charges/allowances The amount specified is the total of all charges/allowances.
134	Total declared The total value of declared amounts.
138	Total monetary discount amount Total of monetary discount amounts.
139	Total payment amount A complete charge for goods or services rendered.
140	Total service charge The complete payment owed to one who has performed work for another.

Used Codes

142	Trade discount Discount given to any purchaser at a particular commercial level e.g. at wholesale or retail level.
143	Transfer amount The amount which has been transferred from buyer to the sellers bank.
144	Transport charges (Customs) (5292) Cost incurred by shipper in moving goods, by whatever means, from one place to another under the terms of the contract of carriage, see UN/ECE Recommendation No 23. Synonym: freight charges (Customs).
146	Unit price (5110) Reporting monetary amount is a "per unit" amount.
150	Value added tax [5490] Amount in national currency resulting from the application, at the appropriate rate, of value added tax (or similar tax) to the invoice amount subject to such tax.
157	Insurance value (5010) Value for which the goods are insured.
159	Licence (value deducted) Amount in the currency of the licence to be written off from the total licence value.
161	Duty, tax or fee amount Amount of duty, tax or fee.
165	Adjustment amount Amount being the balance of the amount to be adjusted and the adjusted amount.
176	Message total duty/tax/fee amount Total of all duty/tax/fee amounts.
177	Message total amount prepaid Total of all prepaid amounts within the message.
178	Exact amount Specific amount. GS1 Description: A specific monetary amount.
200	Minimum amount due The minimum amount that must be paid on an amount now due for payment.
201	Penalty amount The penalty charge incurred if or because conditions are not met. GS1 Description: A value indicating a penalty amount.

Used Codes

202	Interest amount The amount of interest charged or paid on a debit or credit balance.
203	Line item amount Goods item total minus allowances plus charges for line item. See also Code 66.
204	Allowance amount The amount of an allowance.
209	Agent commission amount Amount which has to be paid to an agent.
210	Credit note amount Amount of a credit note.
211	Debit note amount Amount of a debit note.
212	Documentary credit amount Amount of the documentary credit.
227	Deposit Part of the amount of retention, not covered by guarantee of retention, and thus deducted from the amount paid to the contractor until release of retention. GS1 Description: The money paid as a guarantee in case one damages or loses something one is renting. This money is returned if no damage is caused.
236	Amount subject to price adjustment Amount which is used as the basis for price adjustment calculation.
257	Amount subject to dispute The amount that is being disputed.
259	Total charges Self-explanatory. GS1 Description: Total charges amount.
260	Total allowances Self-explanatory.
262	Instalment amount Amount paid or due for a single instalment of an instalment payment scheme.
263	Outstanding amount Amount still remaining outstanding for payment.
265	Commission amount Amount of any commission.

Used Codes

271	Nominal salary The salary amount without special allowances or other cash benefits.
272	Taxable salary The salary amount which is taxable.
276	Annual salary Self-explanatory.
277	Total contributions amount Sum of individual contributions.
278	Voluntary contribution amount The amount is for a non-compulsory contribution.
286	Administration charge Charge made for an administration activity.
289	Subtotal amount Total amount of money that is part of a complete amount.
296	Total authorised deduction Total amount of authorised deductions.
304	Other charges Miscellaneous charges.
315	Opening balance (SWIFT Code) The amount of the opening balance.
343	Closing balance (SWIFT Code) The closing balance is the last balance for a reporting period.
344	Value date balance (SWIFT Code) This is the balance on value date.
345	Cost amount for providing the balance (SWIFT Code) Cost information for providing the statement.
346	Total credits (SWIFT Code) The total of all credit items reported.
347	Total debits (SWIFT Code) The total of all debit items reported.
348	Booked amount on the account (SWIFT Code) Booked amount on the account.
349	Pending amount to be booked on account (SWIFT Code) The amount which is pending booking on a financial account.
350	Damage repair cost Cost incurred by repair of the damage.

Used Codes

357	Interim opening balance (SWIFT Code) The opening balance of a consecutive statement.
358	Interim closing balance (SWIFT Code) The closing balance of a consecutive statement.
359	Balance to be confirmed for audit reasons Balance to be confirmed for audit reasons.
360	Accrued debit interest (SWIFT Code) Accrued debit interest.
361	Accrued credit interest (SWIFT Code) Accrued credit interest.
369	Goods and services tax Amount charged as tax on goods and services.
388	Total amount including Value Added Tax (VAT) The total monetary amount which includes the Value Added Tax (VAT).
396	Total price subsidy value The total value of all price subsidies.
397	Advertising amount Amount related to advertising.
400	Rebate amount The amount of a rebate.
401	Debt financing charge A charge amount related to the financing of a debt.
402	Total retail value The total retail value of all products.
462	Annual turnover The annual turnover.
496	Total returnable packages deposit amount Total deposit amount for returnable packages.
497	Goods and services total amount excluding returnable goods Total amount of goods and services excluding deposits for returnable goods.
503	Contract total amount Total value of a contract.
505	Rental amount The amount to be paid for the right to use a place, product or service.
506	Gross-progress payment amount Gross monetary amount paid or to be paid at intervals.

Used Codes

507	Net-progress payment amount Net monetary amount paid or to be paid at intervals.
508	Value of returned product Value of product returned by the customer.
509	Unit allowance amount The monetary amount of an allowance for each unit.
526	Volume discount A discount for reaching or exceeding an agreed volume.
527	Product range discount Discount for the purchase of a whole range of products.
528	Calculation basis excluding all taxes The amount used as the basis for calculation excludes all taxes.
529	Calculation basis which includes all taxes except VAT The amount, used as the basis for calculation, which includes all taxes except Value Added Tax (VAT).
542	Unloading and handling cost Cost incurred by unloading and handling.
544	Taxable amount - excluding payment discount amount Indication of the total taxable amount before deducting payment discount amount.
545	Must buy product in multi-buy promotions value The value of a product which must be bought in order to qualify for the multi-buy promotion. GS1 Note: Replaces GS1 Temporary Code 29E.
546	Additional voluntary contribution amount Additional voluntary contribution amount paid by the employee. GS1 Note: Replaces GS1 Temporary Code 33E.
547	Interest amount over employee's obligatory contribution Interest amount calculated over the employee's obligatory contribution. GS1 Note: Replaces GS1 Temporary Code 34E. EDIFACT code added, replacing GS1 code 34E
548	Prepaid amount related to the obligatory contribution Prepaid amount related to the employee's obligatory contribution. GS1 Note: Replaces GS1 Temporary Code 39E.
549	Amount to be compensated between social security entities Amount which needs to be compensated between social security entities. GS1 Note: Replaces GS1 Temporary Code 40E.
550	Bank check amount Amount to be paid by bank check.

Used Codes

10E	Value of coins (GS1 Temporary Code) The amount of change which is given by cigarette vending machines.
28E	Financing allowance/charge (GS1 Temporary Code) A charge or allowance related to the financing of a debt.
29E	Multi-buy promotion value (GS1 Temporary Code) A value of a product included in a multi-buy promotion which must be purchased in order to qualify for the multi-buy promotion. GS1 Note: Code marked for deletion. Use value 545 instead.
32E	Exceptional situation amount (GS1 Temporary Code) Amount of the exceptional situation that affects the normal contribution of the employee in a given period.
33E	Additional voluntary contribution amount (GS1 Temporary Code) Additional voluntary contribution amount paid by the employee. GS1 Note: Code marked for deletion. Use value 546 instead.
34E	Interest amount over employee's obligatory contribution (GS1 Temporary Code) Interest amount calculated over the employee's obligatory contribution (GS1 Temporary Code) GS1 Note: Code marked for deletion. Use value 547 instead.
35E	Total returnable items deposit amount (GS1 Temporary Code) Total deposit amount for returnable items.
39E	Prepaid amount related to the obligatory contribution (GS1 Temporary Code) Prepaid amount related to the employee's obligatory contribution. GS1 Note: Code marked for deletion. Use value 548 instead.
40E	Amount to be compensated between social security entities (GS1 Temporary Code) Amount which needs to be compensated between social security entities. GS1 Note: Code marked for deletion. Use value 549 instead.
41E	Interest over solidarity fund (GS1 Temporary Code) Interest to pay because contribution to solidarity fund was not paid on time.
42E	Interest over employee additional contribution (GS1 Temporary Code) Interest to pay because contribution to employee additional contribution was not paid on time.
X41	Total returnable items rental fee amount (GS1 Temporary Code) Total rental fee amount for returnable items.
X42	Rental fee (GS1 Temporary Code) The amount charged for the rental of an item.
XB5	Information amount (SWIFT Code) A monetary amount provided for information purposes.

Used Codes

XB6	Beneficiary's account number unknown (SWIFT Code) The account number of the beneficiary is unknown.
5125	Price code qualifier Code qualifying a price. Notes: 1. The code set from data element 5387 may also be used as agreed among trading partners.
1E	Calculation net - including taxes (GS1 Temporary Code) The price stated is the net price including all allowances and charges, and including taxes. Allowances and charges may be stated for information purposes only.
AAA	Calculation net The price stated is the net price including allowances/ charges. Allowances/ charges may be stated for information only. GS1 Description: The price stated is the net price including allowances/ charges and excluding taxes. Allowances/charges may be stated for information only.
AAB	Calculation gross The price stated is the gross price to which allowances/charges, if valid, must be applied. GS1 Description: The price stated is the gross price excluding all allowances, charges and taxes. Allowances and charges must be stated and used for net calculation purposes.
AAE	Information price, excluding allowances or charges, including taxes The price stated is for information purposes only and excludes all allowances and charges. Taxes however are included in the price.
AAF	Information price, excluding allowances or charges and taxes The price stated is for information purposes only and excludes all allowances, charges and taxes.
AAH	Subject to escalation and price adjustment Subject to increase or development by successive stages and price adjustment.
AAQ	Firm price Price which will remain unchanged for a given time period.
ABL	Base price The base price of a product or service.
ABM	Base price difference The difference in price against a base price.
CAL	Calculation price The price stated is the price for the calculation of the line item amount.

Used Codes

INF	Information The price is provided for information.
5153	Duty or tax or fee type name code Code specifying a type of duty, tax or fee.
100	Insurance tax (GS1 Temporary Code) A tax levied specifically on insurances.
AAD	Tobacco tax A tax levied on tobacco products.
AAF	Coffee tax A tax levied specifically on coffee products.
AAJ	Tax on replacement part A tax levied on a replacement part, where the original part is returned. GS1 Description: A tax levied on replacement parts, calculated as a second VAT.
AAK	Mineral oil tax Tax that is levied specifically on products containing mineral oil.
ACT	Alcohol tax (GS1 Temporary Code) A tax levied specifically on alcoholic products.
CAR	Car tax A tax that is levied on the value of the automobile. GS1 Description: A tax levied on the ownership or use of cars.
ENV	Environmental tax Tax assessed for funding or assuring environmental protection or clean-up.
EXC	Excise duty Customs or fiscal authorities code to identify a specific or ad valorem levy on a specific commodity, applied either domestically or at time of importation.
GST	Goods and services tax Tax levied on the final consumption of goods and services throughout the production and distribution chain.
IMP	Import tax Tax assessed on imports.
OTH	Other taxes Unspecified, miscellaneous tax charges.
VAT	Value added tax A tax on domestic or imported goods applied to the value added at each stage in the production/distribution cycle.

Used Codes

5189	Allowance or charge identification code Code specifying the identification of an allowance or charge.
1	Handling commission Fee for the processing of documentary credit, collection and payment which are charged to the customer.
13	Domiciliation commission Fee for the domiciliation of bills with the bank.
29	Brokerage Brokers commission arising, in trade with foreign currencies.
30	Bank charges Charges deducted/claimed by other banks involved in the transaction.
32	Courier fee Fee for use of courier service.
35	S.W.I.F.T. fee Fee for use of S.W.I.F.T.
64	Special agreement An allowance or charge as specified in a special agreement.
65	Production error discount A discount given for the purchase of a product with a production error.
66	New outlet discount A discount given at the occasion of the opening of a new outlet.
67	Sample discount A discount given for the purchase of a sample of a product.
68	End-of-range discount A discount given for the purchase of an end-of-range product.
69	Charge for a customer specific finish A charge for the addition of a customer specific finish to a product.
70	Incoterm discount A discount given for a specified Incoterm.
101	Carbon footprint charge A monetary amount charged for carbon footprint related to a regulatory requirement.
102	Fixed long term A fixed long term allowance or charge. GS1 Note: Replaces GS1 Temporary Code 60E.
103	Temporary A temporary allowance or charge. GS1 Note: Replaces GS1 Temporary Code 61E.

Used Codes

104	Standard The standard available allowance or charge. GS1 Note: Replaces GS1 Temporary Code 62E.
105	Yearly turnover An allowance or charge based on yearly turnover. GS1 Note: Replaces GS1 Temporary Code 64E.
60E	Fixed long term (GS1 Temporary Code) A fixed long term allowance or charge. GS1 Note: Code marked for deletion. Use value 102 instead.
61E	Temporary (GS1 Temporary Code) A temporary allowance or charge. GS1 Note: Code marked for deletion. Use value 103 instead.
62E	Standard (GS1 Temporary Code) The standard available allowance or charge. GS1 Note: Code marked for deletion. Use value 104 instead.
64E	Yearly turnover allowance/charge (GS1 Temporary Code) An allowance or charge based on yearly turnover. GS1 Note: Code marked for deletion. Use value 105 instead.
5245	Percentage type code qualifier Code qualifying the type of percentage.
1	Allowance (5424) Allowance expressed as a percentage.
2	Charge (5424) Charge expressed as a percentage.
3	Allowance or charge [5424] Allowance or charge expressed as a percentage.
7	Percentage of invoice Code specifying the percentage of invoice.
9	Adjustment Code specifying the adjustment expressed as a percentage.
12	Discount Discount expressed as a percentage.
15	Penalty percentage Code specifying the penalty percentage. GS1 Description: Percentage which will be/has been charged as a penalty.

Used Codes

16	Interest percentage Code specifying the interest percentage. GS1 Description: Interest percentage which will be/has been charged or allowed.
18	Percentage credit note Percentage of a credit note.
19	Percentage debit note Percentage of a debit note.
68	Percentage of due amount The percentage of an amount due.
159	Nestable percentage Extent expressed as a percentage to which an item can be nested within an identical item.
161	Transport weight completed The percentage of a transport weight that has been completed. GS1 Note: Replaces GS1 Temporary Code 10E.
162	Transport volume completed The percentage of a transport volume that has been completed. GS1 Note: Replaces GS1 Temporary Code 11E.
163	Percentage of order Percentage of an order. GS1 Note: Replaces GS1 Temporary Code 9E.
10E	Transport weight completed (GS1 Temporary Code) The percentage of a transport weight reported as completed in a status report. GS1 Note: Code marked for deletion. Use value 161 instead.
11E	Transport cube completed (GS1 Temporary Code) The percentage of a transport cube reported as completed in a status report. GS1 Note: Code marked for deletion. Use value 162 instead.
9E	Percentage of order (GS1 Temporary Code) The percentage of an order to which a status report applies. GS1 Note: Code marked for deletion. Use value 163 instead.
5249	Percentage basis identification code Code specifying the basis on which a percentage is calculated.
1	Per unit Referenced percentage applies on a single unit basis.
13	Invoice value Referenced percentage applies on the invoice value.

Used Codes

5273	Duty or tax or fee rate basis code Code specifying the basis for a duty or tax or fee rate.
1	Value (5316) To specify that the applicable rate of duty, tax or fee is based on the Customs value (CCC).
2	Weight (6150) To specify that the applicable rate of duty, tax or fee is based on the weight of the item (CCC).
3	Quantity (6060) To specify that the applicable rate of duty, tax or fee is based on the quantity of the item (CCC).
5283	Duty or tax or fee function code qualifier Code qualifying the function of a duty or tax or fee.
5	Customs duty Duties laid down in the Customs tariff to which goods are liable on entering or leaving the Customs territory (CCC).
6	Fee Charge for services rendered.
7	Tax Contribution levied by an authority.
5305	Duty or tax or fee category code Code specifying a duty or tax or fee category.
A	Mixed tax rate Code specifying that the rate is based on mixed tax. GS1 Description: Transaction includes item taxed at different rates.
AA	Lower Rate Tax rate is lower than standard rate.
AC	Value Added Tax (VAT) not now due for payment A code to indicate that the Value Added Tax (VAT) amount which is due on the current invoice is to be paid on receipt of a separate VAT payment request. GS1 Description: The value added tax is not due for payment now.
AE	VAT Reverse Charge Code specifying that the standard VAT rate is levied from the invoicee. GS1 Description: Code specifying that the rate is based upon the reverse charge VAT treatment which is always standard rate tax.

Used Codes

C	Duty paid by supplier Duty associated with shipment of goods is paid by the supplier; customer receives goods with duty paid.
D	Value Added Tax (VAT) margin scheme - travel agents Indication that the VAT margin scheme for travel agents is applied.
E	Exempt from tax Code specifying that taxes are not applicable. GS1 Description: All items in the transaction or a specific line item are exempt from tax.
F	Value Added Tax (VAT) margin scheme - second-hand goods Margin scheme for second-hand goods.
G	Free export item, tax not charged Indication that the VAT margin scheme for second-hand goods is applied.
H	Higher rate Code specifying a higher rate of duty or tax or fee. GS1 Description: All items in the transaction or a specific line item are taxed at the higher rate of tax.
I	Value Added Tax (VAT) margin scheme - works of art Indication that the VAT margin scheme for works of art is applied.
J	Value Added Tax (VAT) margin scheme - collector's items and antiques Indication that the VAT margin scheme for collector's items and antiques is applied.
O	Services outside scope of tax Code specifying that taxes are not applicable to the services.
S	Standard rate Code specifying the standard rate. GS1 Description: All items in the transaction or a specific line item are taxed at the standard rate of tax.
Z	Zero rated goods Code specifying that the goods are at a zero rate. GS1 Description: All items in the transaction or a specific line item are zero tax rated.
5375	Price type code Code specifying the type of price.
AE	Range dependent price A code identifying the price for a specific range of purchase quantities.

Used Codes

CA	Catalogue Code specifying the catalogue price. GS1 Description: The price detailed is the price detailed in the currently referenced catalogue.
CT	Contract Code specifying the contract price. GS1 Description: The price detailed is the price detailed in the currently referenced contract.
DI	Distributor Code specifying the distributor price.
5387	Price specification code Code identifying pricing specification.
AAB	Price includes tax Code specifying that the price is inclusive of tax.
AAC	Buyer suggested retail price The suggested retail price as suggested or determined by the party purchasing the goods.
AAE	Not subject to fluctuation Not subject to escalation or adjustment.
AAF	Subject to escalation Subject to increase or development by successive stages.
AAG	Subject to price adjustment Code specifying that the price is subject to adjustment.
AAK	New price A price valid from an effective date/time/period.
AAL	Old price A price valid prior to an effective date/time/period of a new price.
ABA	Individual buyer price A price which is available to an individual buyer as opposed to an institutional buyer.
ABB	Group buying price A price which is available to a buying group.
ABC	Group member buying price A special price given to a member of a buying group.
ABD	Pre-payment price A special price if pre-payment is made for the article ordered.
ABE	Retail price - excluding taxes Retail price not including any applicable taxes.

Used Codes

ABF	Suggested retail price - excluding taxes Suggested retail price not including any applicable taxes.
ABH	Statutory minimum retail price The legal minimum retail price. EDIFACT
ABM	Base price difference The difference in price against a base price. GS1 Description: The difference in price between the price of a base article in a Customer Specific Article (CSA) and the price of a component part of the CSA configuration.
ACA	Agreed minimum retail price The agreed minimum retail price for an article. GS1 Note: Replaces GS1 Temporary Code AMP.
ACB	Marked retail price The retail price of a product which has been marked on the products packaging. GS1 Note: Replaces GS1 Temporary Code MRP.
ALT	Alternate price A substitute cost.
AMP	Agreed minimum retail price (GS1 Temporary Code) The agreed minimum retail price for an article. GS1 Note: Code marked for deletion. Use value ACA instead.
AP	Advice price Code specifying an advice price.
BAP	Base article price (GS1 Temporary Code) The price of a base article in a Customer Specific Article.
CP	Current price Price at time of transaction, but subject to future change.
CU	Consumer unit Code specifying that the price is based on consumer unit.
DAP	Dealer adjusted price The necessary or desirable changes that the sales agency makes with respect to the value of the product.
DIS	Distributor price The cost associated with the agency that markets goods.
DPR	Discount price A reduction from the usual list value.

Used Codes

DR	Dealer price Code specifying a dealer price. GS1 Description: Price associated with the dealer of the product.
ES	Estimated price Code specifying an estimated price. GS1 Description: An estimated price of the product which will later be confirmed.
EUP	Expected unit price The anticipated value of a single item.
GRP	Gross unit price Unit price to which allowances and charges apply.
INV	Invoice price Price per unit of quantity of a product as specified on an invoice.
LBL	Labelling price Retail price of the buyer that should be printed by the producer on the article's label. The labelling price is not necessary the effective retail price.
LIU	List price (GS1 Temporary Code) Regular list price (no promotions or special discounts applied).
MAX	Maximum order quantity price The greatest amount of goods or services which one can buy to receive a certain value.
MIN	Minimum order quantity price The least amount of goods or services that one can buy to receive a certain value.
MRP	Marked retail price (GS1 Temporary Code) The retail price of a product which has been marked on the products packaging. GS1 Note: Code marked for deletion. Use value ACB instead.
NE	Not-to-exceed price Code specifying a price that cannot be increased. GS1 Description: A price which is not to be exceeded.
NTP	Net unit price Unit price to which no allowances and charges apply.
PPD	Prepaid freight charges The cost of shipping is paid before the goods are shipped.
PPR	Provisional price Price per unit of quantity of a product as provisionally agreed.

Used Codes

PRP	Promotional price The value that is placed on an item that is being developed. The idea is to sell this product for less than one normally would, and make up for it by selling a larger quantity.
QTE	Quote price Price per unit of quantity of a product as specified in a quote.
RTP	Retail price Price per unit of quantity of a product to be used for retail.
SRP	Suggested retail price Price per unit of quantity of a product suggested for retail.
TU	Traded unit Code specifying a traded unit price.
5393	Price multiplier type code qualifier Code qualifying the type of price multiplier.
A	Price adjustment coefficient Coefficient to be used in the price adjustment formula to calculate the revaluated price.
5419	Rate type code qualifier Code qualifying the type of rate.
1	Allowance rate Code specifying the allowance rate.
2	Charge rate Code specifying the charge rate.
5463	Allowance or charge code qualifier Code qualifying an allowance or charge.
A	Allowance Code specifying an allowance. GS1 Description: Deduction in the form of a rate, amount, percentage, or quantity to the price or amount charged for a product.
C	Charge Code specifying a charge. GS1 Description: Addition in the form of a rate, amount, percentage, or quantity to the price or amount charged for a product.
N	No allowance or charge No increases or reduction in price (list or stated) are included.

Used Codes

5495	Sub-line indicator code Code indicating a sub-line item.
1	Sub-line information Code indicating a sub-line item.
6063	Quantity type code qualifier Code qualifying the type of quantity.
1	Discrete quantity Individually separated and distinct quantity.
3	Cumulative quantity Quantity accumulated.
11	Split quantity Part of the whole quantity.
12	Despatch quantity Quantity despatched by the seller.
17	Quantity on hand The total quantity of a product on hand at a location. This includes as well units awaiting return to manufacturer, units unavailable due to inspection procedures and undamaged stock available for despatch, resale or use. GS1 Description: Quantity on hand including damaged and committed stock.
18	Previous quantity Quantity previously referenced.
21	Ordered quantity The quantity which has been ordered.
23	Active ingredient Quantity at 100% active agent content.
26	Promotion quantity A quantity associated with a promotional event.
27	On hold for shipment Article received which cannot be shipped in its present form.
28	Military sales quantity Quantity of goods or services sold to a military organization.
29	On premises sales Sale of product in restaurants or bars.
30	Off premises sales Sale of product directly to a store.

Used Codes

40	Normal delivery Quantity normally delivered by the seller.
42	Maximum supply quantity, supplier endorsed Maximum supply quantity endorsed by a supplier.
46	Delivered quantity Number of pieces actually received at the final destination. GS1 Description: Quantity actually delivered to the final destination.
47	Invoiced quantity The quantity as per invoice.
48	Received quantity The quantity which has been received.
52	Quantity per pack Quantity for each pack. GS1 Description: The quantity contained in the currently identified pack.
53	Minimum order quantity Minimum quantity of goods for an order. GS1 Description: The smallest number of units of a product which may be ordered.
54	Maximum order quantity Maximum quantity of goods for an order. GS1 Description: The largest number of units of a product which may be ordered.
57	In transit quantity A quantity that is en route.
58	Quantity withdrawn Quantity withdrawn from a location.
59	Number of consumer units in the traded unit Number of units for consumer sales in a unit for trading. GS1 Description: The number of consumer units (package size of a product agreed between trading partners as the unit crossing the retail point of sale) in a traded unit to be ordered, delivered and invoiced.
60	Current inventory quantity available for shipment Current inventory quantity available for shipment.
61	Return quantity Quantity of goods returned.

Used Codes

65	Destroyed quantity Quantity of goods destroyed. GS1 Description: Quantity of a product which will be/has been destroyed because of damage or freshness loss.
66	Committed quantity Quantity a party is committed to.
73	Outstanding quantity Difference between quantity ordered and quantity received.
74	Latest cumulative quantity Cumulative quantity after complete delivery of all scheduled quantities of the product.
79	Previous cumulative quantity Cumulative quantity prior the actual order.
81	Extra unplanned delivery Non scheduled additional quantity.
83	Backorder quantity The quantity of goods that is on back-order. GS1 Description: Quantity of a product for backorder purposes.
89	Quality control held Quantity of goods held pending completion of a quality control assessment.
92	Final delivery quantity Quantity of final delivery to a respective order.
96	Quality control failed Quantity of goods which have failed quality control.
97	Minimum inventory Minimum stock quantity on which replenishment is based.
98	Maximum inventory Maximum stock quantity on which replenishment is based.
99	Estimated quantity Quantity estimated. GS1 Description: An estimation of stock quantity.
100	Chargeable weight The weight on which charges are based.
101	Chargeable gross weight The gross weight on which charges are based.

Used Codes

109	Chargeable volume The volume on which charges are based.
110	Chargeable cubic measurements The cubic measurements on which charges are based.
113	Quantity to be delivered The quantity to be delivered.
119	Short shipped Indication that part of the consignment was not shipped.
121	Over shipped Indication that more goods have been shipped than contracted for delivery. GS1 Description: The overshipped quantity is the difference between the quantity shipped and the quantity contracted for delivery.
124	Damaged goods Quantity of goods which have deteriorated in transport such that they cannot be used for the purpose for which they were originally intended.
128	Quantity loaded Quantity of goods loaded onto a means of transport.
129	Units per unit price Number of units per unit price.
130	Allowance Quantity relevant for allowance.
131	Delivery quantity Quantity required by buyer to be delivered.
135	Period quantity, planned Quantity planned for this period.
145	Actual stock The stock on hand, undamaged, and available for despatch, sale or use.
146	Model or target stock The stock quantity required or planned to have on hand, undamaged and available for use.
152	Consignment stock Quantity of goods with an external customer which is still the property of the supplier.
153	Statistical sales quantity Quantity of goods sold in a specified period.
156	Inventory movement quantity To specify the quantity of an inventory movement.

Used Codes

157	Opening stock balance quantity To specify the quantity of an opening stock balance.
158	Closing stock balance quantity To specify the quantity of a closing stock balance.
164	Delivery batch Quantity of the referenced item which constitutes a standard batch for deliver purposes.
170	Allocated quantity Quantity of the referenced item allocated from available stock for delivery.
191	Adjustment to inventory quantity An adjustment to inventory quantity.
192	Free goods quantity Quantity of goods which are free of charge.
193	Free quantity included Quantity included to which no charge is applicable. GS1 Description: Free quantity included.
194	Received and accepted Quantity which has been received and accepted at a given location.
195	Received, not accepted, to be returned Quantity which has been received but not accepted at a given location and which will consequently be returned to the relevant party.
196	Received, not accepted, to be destroyed Quantity which has been received but not accepted at a given location and which will consequently be destroyed.
197	Reordering level Quantity at which an order may be triggered to replenish.
198	Quantity in transit Quantity which is currently in transit. Notes: This code value will be removed effective with directory D.04A.
199	Inventory withdrawal quantity Quantity which has been withdrawn from inventory since the last inventory report.
200	Free quantity not included Free quantity not included in ordered quantity.

Used Codes

205	<p>Publication Turn Size</p> <p>The quantity of magazines or newspapers grouped together with the spine facing alternate directions in a bundle.</p> <p>EDIFACT</p>
209	<p>Additional replenishment demand quantity</p> <p>Incremental needs over and above normal replenishment calculations, but not intended to permanently change the model parameters.</p>
210	<p>Returned by consumer quantity</p> <p>Quantity returned by a consumer.</p> <p>GS1 Description:</p> <p>Quantity of product returned by the consumer to the place/party of sale.</p>
211	<p>Replenishment override quantity</p> <p>Quantity to override the normal replenishment model calculations, but not intended to permanently change the model parameters.</p>
212	<p>Quantity sold, net</p> <p>Net quantity sold which includes returns of saleable inventory and other adjustments.</p>
217	<p>Out of inventory quantity</p> <p>Quantity of inventory which was requested but was not available.</p>
243	<p>Reserved quantity customer direct delivery sales</p> <p>Quantity of products reserved for sales delivered direct to the customer.</p>
244	<p>Reserved quantity retail sales</p> <p>Quantity of products reserved for retail sales.</p>
246	<p>Returns replacement quantity</p> <p>A quantity of goods issued as a replacement for a returned quantity.</p>
247	<p>Additional promotion sales forecast quantity</p> <p>A forecast of additional quantity which will be sold during a period of promotional activity.</p>
248	<p>Reserved quantity</p> <p>Quantity reserved for specific purposes.</p>
249	<p>Quantity displayed not available for sale</p> <p>Quantity displayed within a retail outlet but not available for sale.</p>
250	<p>Inventory discrepancy</p> <p>The difference recorded between theoretical and physical inventory.</p>
251	<p>Incremental order quantity</p> <p>The incremental quantity by which ordering is carried out.</p>
252	<p>Quantity requiring manipulation before despatch</p> <p>A quantity of goods which needs manipulation before despatch.</p>

Used Codes

253	Quantity in quarantine A quantity of goods which are held in a restricted area for quarantine purposes.
255	Quantity not available for despatch A quantity of goods not available for despatch.
256	Quantity awaiting delivery Quantity of goods which are awaiting delivery.
257	Quantity in physical inventory A quantity of goods held in physical inventory.
258	Quantity held by logistic service provider Quantity of goods under the control of a logistic service provider.
264	Equipment quantity A count of a quantity of equipment.
266	Unsold quantity held by wholesaler Unsold quantity held by the wholesaler.
267	Quantity held by delivery vehicle Quantity of goods held by the delivery vehicle.
268	Quantity held by retail outlet Quantity held by the retail outlet.
269	Rejected return quantity A quantity for return which has been rejected.
392	Supplier estimated previous meter reading Previous meter reading estimated by the supplier.
393	Supplier estimated latest meter reading Latest meter reading estimated by the supplier.
394	Customer estimated previous meter reading Previous meter reading estimated by the customer.
395	Customer estimated latest meter reading Latest meter reading estimated by the customer.
396	Supplier previous meter reading Previous meter reading done by the supplier.
397	Supplier latest meter reading Latest meter reading recorded by the supplier.
399	File size before compression The size of a file before compression.
400	File size after compression The size of a file after compression.

Used Codes

426	Production requirements Quantity needed to meet production requirements.
440	Number of quantitative incentive scheme units Number of units allocated to a quantitative incentive scheme.
444	Return to warehouse A quantity of products sent back to the warehouse.
445	Return to the manufacturer A quantity of products sent back from the manufacturer.
447	Quantity moved between outlets The quantity of magazines or newspapers grouped together with the spine facing alternate directions in a bundle. EDIFACT
452	En route to warehouse quantity A quantity of products that is en route to a warehouse. EDIFACT
453	En route from warehouse quantity A quantity of products that is en route from a warehouse. EDIFACT
454	Quantity ordered but not yet allocated from stock A quantity of products which has been ordered but which has not yet been allocated from stock. EDIFACT
455	Not yet ordered quantity The quantity which has not yet been ordered. EDIFACT
457	Maximum number of units per shelf Maximum number of units of a product that can be placed on a shelf. EDIFACT
466	Advised but not arrived Goods are advised by the consignor or supplier, but have not yet arrived at the destination.
467	Received but not available Goods have been received in the arrival area but are not yet available.
468	Goods blocked for transshipment process Goods are physically present, but can not be ordered because they are scheduled for a transshipment process.
469	Goods blocked for cross docking process Goods are physically present, but can not be ordered because they are scheduled for a cross docking process.

Used Codes

471	Number of packages for a set Number of packages used to pack the individual items in a grouping of merchandise that is sold together as a single trade item.
472	Number of items in a set The number of individual items in a grouping of merchandise that is sold together as a single trade item.
473	Order sizing factor A trade item specification other than gross, net weight, or volume for a trade item or a transaction, used for order sizing and pricing purposes.
474	Number of different next lower level trade items Value indicates the number of different next lower level trade items contained in a complex trade item.
475	Agreed maximum buying quantity The agreed maximum quantity of the trade item that may be purchased.
476	Agreed minimum buying quantity The agreed minimum quantity of the trade item that may be purchased.
477	Free quantity of next lower level trade item The numeric quantity of free items in a combination pack. The unit of measure used for the free quantity of the next lower level must be the same as the unit of measure of the Net Content of the Child Trade Item.
503	Quantity to be checked Quantity which must be checked and confirmed by the partner.
504	Number of wash loads Number of wash loads or washing machine runs possible per item. EDIFACT
505	Goods in transit not responsibility of party reporting Stock quantity which is not yet under the responsibility of the party reporting the stocks but which is in transit, i.e. not yet in physical possession. GS1 Note: Replaces GS1 Temporary Code 19E.
506	Goods in transit responsibility of party reporting Stock quantity under the responsibility of the party reporting the stocks but which is in transit, i.e. not yet in physical possession. GS1 Note: Replaces GS1 Temporary Code 20E.
507	Free quantity basis A code indicating the basis for a free quantity, e.g. 1 piece free for every 12 purchased, 12 is the basis. GS1 Note: Replaces GS1 Temporary Code 22E.
508	Forecast quantity A quantity used for forecasting purposes. GS1 Note: Replaces GS1 Temporary Code 26E.

Used Codes

509	Sales forecast quantity A quantity of goods used for sales forecasting purposes. GS1 Note: Replaces GS1 Temporary Code 38E.
510	Minimum invoicing quantity Minimum quantity of goods which may be invoiced according to agreed conditions. GS1 Note: Replaces GS1 Temporary Code 39E.
511	Quantity tested Number of items used for testing purposes. GS1 Note: Replaces GS1 Temporary Code 40E.
512	Must buy product quantity in multi-buy promotion Number of products which must be bought in order to qualify for a multi-buy promotion. GS1 Note: Replaces GS1 Temporary Code 44E.
530	Requested promotion quantity out of stock The quantity of promotional goods that was requested but out of stock.
531	Ordered promotion quantity awaiting despatch The quantity of promotional goods that has been ordered and not yet despatched.
532	Unprocessed confirmed sales order The quantity of goods of the confirmed sales order which has not been processed.
533	Unprocessed confirmed sales order promotional quantity The quantity of promotional goods of confirmed sales order which has not been processed.
17E	Number of units in lower packaging or configuration level (GS1 Temporary Code) The number of units contained in lower packaging or configuration level.
19E	Goods in transit not responsibility of party reporting (GS1 Temporary Code) Stock quantity which is not yet under the responsibility of the party reporting the stocks but which is in transit, i.e. not yet in physical possession. GS1 Note: Code marked for deletion. Use value 505 instead.
20E	Goods in transit already responsibility of party reporting (GS1 Temporary Code) Stock quantity already under the responsibility of the party reporting the stocks but which is in transit, i.e. not yet in physical possession. GS1 Note: Code marked for deletion. Use value 506 instead.
22E	Free quantity basis (GS1 Temporary Code) A code indicating the basis for a free quantity, e.g. 1 piece free for every 12 purchased, 12 is the basis. GS1 Note: Code marked for deletion. Use value 507 instead.

Used Codes

26E	Forecast quantity (GS1 Temporary Code) A quantity used for forecasting purposes other than sales forecasting, e.g. manufacturing forecast. GS1 Note: Code marked for deletion. Use value 508 instead.
31E	Promotional stock (GS1 Temporary Code) A quantity of stock reserved for promotional activities.
32E	Consolidated discount stock (GS1 Temporary Code) Additional stock which is greater than the stocks actually ordered which have been supplied in bulk at favourable terms.
38E	Forecast sales quantity (GS1 Temporary Code) A quantity of goods used for sales forecasting purposes. GS1 Note: Code marked for deletion. Use value 509 instead.
39E	Minimum invoicing quantity (GS1 Temporary Code) Minimum quantity of goods which may be invoiced according to agreed conditions. GS1 Note: Code marked for deletion. Use value 510 instead.
40E	Quantity tested (GS1 Temporary Code) A quantity of an item used for testing purposes. GS1 Note: Code marked for deletion. Use value 511 instead.
44E	Multi-buy promotion quantity (GS1 Temporary Code) A quantity of a product included in a multi-buy promotion which must be purchased in order to qualify for the multi-buy promotion. GS1 Note: Code marked for deletion. Use value 512 instead.
45E	Number of units in higher packaging or configuration level (GS1 Temporary Code) The number of units contained in higher packaging or configuration level.
48E	Quantity blocked by owner of goods (GS1 Temporary Code) A quantity of goods, held by a third party, which has been blocked following an instruction by the owner of the goods. These goods must not be used except with the express permission of the owner of the goods.
61E	Available for despatch (GS1 Temporary Code) Quantity of goods which are available to despatch. (Note: This figure is arrived by calculating the sum of 145+256).
62E	Rate of conversion (GS1 Temporary Code) Rate by which the measured unit must be multiplied to calculate the actual units used.
63E	Maximum number of deliveries (GS1 Temporary Code) Maximum number of deliveries allowed during a defined period of time at a specified activity, e.g. a promotion.
71E	Quantity prepared for despatch (GS1 Temporary Code) Quantity which is prepared for despatch.

Used Codes

72E	Average number of units in lower packaging or configuration level (GS1 Temporary Code) The average number of units in lower packaging or configuration level.
75E	Optional quantity (GS1 Temporary Code) Quantity which is optional.
80E	Quantity in customs bond (GS1 Temporary Code) Quantity of goods held in customs bond.
81E	Quantity settling (GS1 Temporary Code) A quantity of product which is settling before it can be used.
82E	Outstanding promotion products quantity (GS1 Temporary Code) The difference between a quantity ordered and a quantity received of a promotion product. This code should only be used where a promotional agreement covering prices and/or quantities exists between the buyer and the supplier.
83E	Promotion quantity ordered to the supplier but not yet received (GS1 Temporary Code) A quantity of promotion products which has been ordered but which is not yet been received at the delivery point. This code should only be used where a promotional agreement covering prices and/or quantities exists between the buyer and the supplier.
84E	Movements out of promotion inventory (GS1 Temporary Code) The quantity which has moved out of promotion inventory. This code should only be used where a promotional agreement covering prices and/or quantities exists between the buyer and the supplier.
85E	Movements into promotion inventory (GS1 Temporary Code) The quantity which has been received into the promotion inventory.
86E	Out of inventory promotion quantity (GS1 Temporary Code) Promotion quantity of inventory which was requested but was not available.
87E	Ordered promotions quantity but awaiting despatch (GS1 Temporary Code) A promotions quantity of goods which have been ordered but are awaiting delivery.
88E	Reserved inventory promotion quantity (GS1 Temporary Code) Promotion quantity for the reserved inventory.
89E	Additional promotions replenishment demand quantity (GS1 Temporary Code) Incremental promotion needs over and above normal replenishment calculations, but not intended to permanently change the model parameters.
90E	Back order promotion quantity (GS1 Temporary Code) The promotion quantity which has been ordered, but not delivered.
91E	Promotional ordered quantity (GS1 Temporary Code) Quantity of ordered product related to a promotion.

Used Codes

92E	Produced quantity (GS1 Temporary Code) The quantity which has been produced.
93E	Extraordinary sale (GS1 Temporary Code) Sales which will not be included in the calculation of replenishment requirements, e.g. sales to staff, to sport clubs, etc.
X11	Incentive unit basis (GS1 Temporary Code) Unit basis used to calculate quantitative incentive schemes.
X20	Reserved quantity, provisional (GS1 Temporary Code) A quantity of stock provisionally reserved prior to a formal decision.
X22	Consignment stock, available on ordering (GS1 Temporary Code) A quantity of products in consignment stock which become available to the buyer when they have been ordered.
X23	Consignment stock, available on agreement (GS1 Temporary Code) A quantity of products in consignment stock which become available to the buyer after an agreement has been reached.
X24	Consignment stock, available at due date (GS1 Temporary Code) A quantity of products in consignment stock which become available to the buyer at a scheduled due date.
6069	Control total type code qualifier Code qualifying the type of control of hash total.
1	Total value of the quantity segments at line level in a message Self-explanatory. GS1 Description: The total value of all QTY segments at line level within a message.
2	Number of line items in message Self-explanatory. GS1 Description: The total number of LIN segments in a message.
7	Total gross weight Code to indicate total gross weight of a consignment.
11	Total number of packages Total number of packages of the entire consignment.
15	Total consignment, cube The total cube of consignment.
26	Total gross measurement/cube Total gross cubic measurement of the goods, including packing but excluding transport equipment.

Used Codes

6311	Measurement purpose code qualifier Code qualifying the purpose of the measurement.
AAA	Line item measurement Line item measurement specified by the Food and Drug Administration.
AAB	Transport conditions for delivery to distribution centre Specified measurements refer to transport conditions for delivery to a distribution centre.
AAC	Retail container size Size of a retail container in terms of volume.
AAE	Measurement [6314] Value of the measured unit.
AAF	Customs line item measurement The measurement of a consignment or part for customs purpose.
AAG	Percentage of alcohol (by volume) The measurement of the alcohol content. GS1 Description: The measurement of the percentage of alcohol by volume.
AAH	Dimensions total weight The total weight of an identified dimension.
AAI	Item weight Weight at line item level.
AAU	Package Commodity/product shipped or sold in discrete individual containers which may be accumulated in a larger package.
ABA	Unit of measure used for ordered quantities The unit of measure in which ordered quantities are expressed.
ABB	Transport conditions for delivery to market Specified measurements refer to transport conditions for delivery to the market.
ABC	Storage conditions to guarantee product freshness until best before date Specified measurements refer to storage conditions to guarantee the product freshness until best before date.
ABL	Internal dimension The inner measurement of the referenced item or package. EDIFACT

Used Codes

ABO	<p>Comparison price measurement A measurement used for comparison pricing purposes. GS1 Description: A code to identify measurements for system or shelf edge labelling pricing comparison purposes, e.g. price of a 225 gram of caviar is 200 EUR, price per 100 grams is 89 EUR.</p>
ABW	<p>Unit of measure used for invoiced quantities Unit of measure of invoiced quantity.</p>
ABX	<p>Usable or consumable content Measurement of usable or consumable contents.</p>
AMT	<p>Amount (GS1 Temporary Code) A code to provide monetary range information applicable to allowances or charges, e.g. 5% discount for orders between 5000 and 10000 EUR.</p>
CHW	<p>Chargeable weight The weight on which charges are based.</p>
CT	<p>Counts The measurement is counts.</p>
DT	<p>Dimensional tolerance Possible range of values for a specified measurement dimension of a product, material or package.</p>
DV	<p>Discrete measurement value The measurement specified is separate and distinct from other measurements.</p>
EGW	<p>Estimated gross weight (GS1 Temporary Code) Estimated weight (mass) of goods, including packing.</p>
FCT	<p>Fat content (GS1 Temporary Code) A code to indicate the fat content of a product, e.g. cheese.</p>
LL	<p>Lift limitation A measurement indicating lift capacity limitations.</p>
LMT	<p>Loading metre The length in a vehicle, whereby the complete width and height over that length is needed for the goods.</p>
MV	<p>Measured value (GS1 Temporary Code) Specification of a value which was measured for test purposes.</p>
PD	<p>Physical dimensions (product ordered) Specified measurement dimensions refer to physical dimensions of a product, material or package. GS1 Description: The restriction 'product ordered' can be ignored.</p>

Used Codes

RL	Receiving facility limitations Specified measurement dimensions are provided as a result of limitations or restrictions related to the physical dimensions of a product, material or package at the reception point.
SH	Shipping tolerance Tolerances related to shipping.
SO	Storage limitation A measurement indicating limitation in relation to storage.
SV	Specification value A measurable item characteristic specified by the buyer, seller or third party.
TL	Transportation equipment limitations A measurement indicating limitations in relation to transportation equipment.
TR	Test result Indicates that the data to follow is the test result measurements.
UTV	Unit total volume of pure alcohol (GS1 Temporary Code) The measurement of the unit total volume of pure alcohol.
VO	Observed value (GS1 Temporary Code) The reported test result which includes measurement variability.
VT	True value (GS1 Temporary Code) The reported test result with the measurement variability removed.
X4E	Retail container dimension (GS1 Temporary Code) Single physical dimension of a retail container.
X5E	Colour (GS1 Temporary Code) The colour of an object.
X6E	Size (GS1 Temporary Code) Dimensions or magnitude of an object.
Y2E	Maximum dimensions using a functionality (GS1 Temporary Code) Maximum dimension of an article using a functionality (e.g. extendable sofa)
Y3E	Minimum dimensions using a functionality (GS1 Temporary Code) Minimum dimension of an article using a functionality (e.g. folding chair)
Y4E	Mattress dimensions (GS1 Temporary Code) Dimension of a mattress, i.e. not the total dimension of the bed frame.
Y5E	Seat dimensions (GS1 Temporary Code) Seat dimension of a chair etc., not total dimension.
6313	Measured attribute code Code specifying the attribute measured.

Used Codes

A	Consolidated weight The measured consolidated weight.
AAA	Unit net weight GS1 Description: Weight (mass) of the goods without any packing.
AAB	Unit gross weight [6292] Weight (mass) of goods including packing but excluding the carrier's equipment.
AAC	Total net weight Total weight of goods excluding packaging. GS1 Description: "Total" in this code means the sum of the net weight of all items.
AAD	Total gross weight [6292] Weight (mass) of goods including packing but excluding the carrier's equipment. GS1 Description: "Total" in this code means the sum of the gross weight of all items.
AAJ	Number of units per pallet The number of units contained on a pallet. GS1 Description: An indication of the number of units on a loaded pallet. The value associated with this code is calculated by multiplying the number of units per layer by the number of layers on a pallet.
AAK	Fat content An indication of the fat content of a product.
AAL	Net weight GS1 Description: Weight (mass) of goods excluding packaging. GS1 usage note: The field of implementation of this code is the area of transport and related activities such as the preparation of goods into consignments for shipping.
AAO	Humidity Self-explanatory.
AAP	Voltage Self-explanatory.
AAQ	Power consumption Value of energy consumption.
AAR	Heat dissipation Self-explanatory.
AAU	Operative temperature Temperature identified system or process works according to specifications.

Used Codes

AAW	Gross volume The observed volume unadjusted for factors such as temperature or gravity. GS1 Description: The usage of this code relates to the contents, e.g. gases or liquids that expand/contract under given circumstances.
AAX	Net volume The observed volume after adjustment for factors such as temperature or gravity. GS1 Description: The usage of this code relates to the contents, e.g. gases or liquids that expand/contract under given circumstances.
AAY	Water content Water content in product.
ABF	Item width when unrolled The width of an item when unrolled.
ABG	Item length when unrolled The length of an item when unrolled.
ABH	Item area when unrolled The area occupied by an item when unrolled.
ABI	Original wort Measure of the malt and hops content of beer, before fermentation has taken place.
ABJ	Volume The amount of air space taken up by the entity identified in the 6311 qualifier. GS1 Description: The usage of this code relates to the cube of air that the package takes up.
ABK	Angle The angle of an object. EDIFACT
ABL	Peg hole horizontal distance from package leftmost edge Horizontal distance from the left most edge of the package to the center of the hole into which the peg is inserted. EDIFACT
ABM	Peg hole vertical distance from top Vertical distance from the top of the package to the top of the hole into which the peg is inserted. EDIFACT
ABO	Product strength, chemical The amount of the single active chemical ingredient within a product. EDIFACT

Used Codes

ABP	Product strength basis, chemical Amount of product used as the basis for the specification of the chemical product strenght. EDIFACT
ABQ	Percentage of alcohol (by volume) The percentage of alcohol contained in a liquid.
ACG	Chargeable weight The weight on which charges are based.
ACN	Estimated gross weight Estimated weight (mass) of goods, including packing and excluding carrier's. GS1 Description: Estimated gross weight (mass) of goods, including packing and excluding carrier's equipment.
ACP	Estimated volume Estimated size or measure of anything in three dimensions. GS1 Description: The usage of this code relates to the cube of air that the package takes up.
ACV	Loading meters The length in a vehicle, whereby the complete width and height over that length is needed for the goods.
ADJ	Surface (GS1 Temporary Code) A measurement in relation a surface.
ADX	Transport container actual filling weight Actual filling weight of a transport container.
ADY	Transport container maximum capacity Maximum capacity of a transport container.
ADZ	Declared net weight The declared net weight of a product or products used for invoicing, customs or transport purposes. GS1 Description: The field of implementation of this code is the area of transport and/or customs.
AEA	Loading height Maximum height of products or packages loaded onto a given transportation device or equipment such as a pallet.
AEB	Stacking height Maximum height up to which the same product or package may be placed one upon the other for storage purposes.
AEI	Drained weight The weight of a product when all liquids used in the packaging of the product have been removed.

Used Codes

AEL	Area Extent or measure of a surface.
AEV	Acidity of juice Acid measurement of juice. GS1 Description: Acid number of juice of fruit measured with pH = 8.2.
AEW	Penetrometry Measurement of force required to drive a standard penetrating stamp.
AEX	Durofel Measurement of the elastic force using a standard penetrating stamp. GS1 Description: Measure of the elastic force of the pulp of a fruit. This is measured with a penetrating stamp and expressed as a percentage.
AEY	Juice weight per 100 grams Measurement of weight of juice, based on 100 grams of the entire weight. GS1 Description: Weight of juice, based on 100 grams of the entire fruit, expressed as a percentage.
AEZ	Fruit skin colour Measurement of the colouring of the epidermis of a fruit. GS1 Description: Colouring of the epidermis of a fruit measured with comparators. It indicates the maturity of the fruit or its commercial quality.
AFB	Durofel D10 Measure of the elastic force of the pulp of a fruit. It is measured with a penetrating stamp with diameter 10. GS1 Description: Measure of the elastic force of the pulp of a fruit. It is measured with a penetrating stamp with diameter 10. This measure is expressed as a percentage.
AFC	Durofel D25 Measure of the elastic force of the pulp of a fruit. It is measured with a penetrating stamp with diameter 25. GS1 Description: Measure of the elastic force of the pulp of a fruit. It is measured with a penetrating stamp with diameter 25. This measure is expressed as a percentage.
AFD	Durofel D50 Measure of the elastic force of the pulp of a fruit. It is measured with a penetrating stamp with diameter 50. GS1 Description: Measure of the elastic force of the pulp of a fruit. It is measured with a penetrating stamp with diameter 50. This measure is expressed as a percentage.

Used Codes

AFE	Maximum stacking weight The maximum weight which may be stacked upon a product or package without the product or packaging being crushed.
AFF	Gross measure cube The total cubic space occupied by an item, taking into account any protruding components, arrived at by multiplying the maximum length, width and height.
AFG	Percentage fat content in dry matter The percentage of fat content in dry matter.
AFH	Saccharometric content Measurement of the sugar content of a solution. EDIFACT
AFI	Hydrate content of an alcoholic product after bottling The hydrate content which occurs in an alcoholic product after bottling.
AFJ	Anhydrous content The non-water content. GS1 Description: Anhydrous content of an alcoholic product.
AFT	Colour depth The number of distinct colours represented, e.g. in an image or in a display.
AFU	Colour depth, maximum The maximum number of distinct colours that can be represented, e.g. in an image or in a display.
AFV	Image resolution The level of detail of an image.
AFW	Device resolution, maximum The maximum level of detail produced by a device.
AFX	Acoustic absorption coefficient The portion of sound energy a surface absorbs, measured at different frequencies.
BNU	Peg hole number Used to identify the peg hole if more than one hole is present in the product or packaging.
BNV	Number of inner packs Indicates the number of non coded physical groupings (inner packs) of next lower level trade items within the current trade item level.
BNW	Number of next level trade items within inner pack The number of next lower level trade items contained within the physical non-coded grouping (inner pack).
BNX	Number of trade items per pallet layer The number of trade items contained on a single layer of a pallet.

Used Codes

BNY	Packed items layer Height The height of a single layer of packed items.
BNZ	Packing material weight, skin tight covering The weight measurement of the packing material used for skin tight covering (e.g. when packaging prepared meats, poultry, cheese, and other food products).
BRB	Components labelled for recycling percentage Percentage of trade item components that clearly label how to facilitate product disassembly and recycling.
BRC	Renewable plastic components percentage, by net weight The percentage of the plastic components only made from rapidly renewable plant-based material by net weight of product.
BRD	Clamp pressure, required The pressure that should be applied by a clamp.
BUP	Number of base units per pallet (GS1 Temporary Code) The number of base units contained in a pallet.
CF1	Colony forming Unit (GS1 Temporary Code) Micro-organism colonies that are to be counted under determined conditions.
CT	Contents of package In combination with the other data elements of the actual segment this code indicates the measured content of a package.
DBX	Degree BRIX (GS1 Temporary Code) The rate of sugar.
DI	Diameter Diameter of an article.
DLL	Diluted liquid (GS1 Temporary Code) The volume of liquid which results after a dilution agent has been added, e.g. undiluted orange juice of 200ml, after dilution with water the volume of diluted liquid equals 1 litre.
DN	Density The measured density.
DP	Depth The measured depth.
ENE	Energy efficiency (GS1 Temporary Code) A measurement of the energy efficiency of an article.

Used Codes

G	Gross weight [6292] Weight (mass) of goods including packing but excluding the carrier's equipment. GS1 Description: The field of implementation of this code is the area of transport and related activities such as the preparation of goods into consignments for shipping.
HT	Height dimension Numeric value of height.
HYE	Hydrate content (GS1 Temporary Code) Hydrate content of an alcoholic product.
ID	Inside diameter The measured inside diameter. GS1 Description: A measurement of the inside diameter of a roll, tube, pipe, or circle.
LAY	Number of layers (GS1 Temporary Code) Number of layers of a product or products within a package, container, pallet, etc. GS1 Description: Number of layers of a product or products within a package, container, pallet, etc.
LN	Length dimension (6168) Length of pieces or packages stated for transport purposes.
MDM	Maximum demand (GS1 Temporary Code) The highest demand recorded during the period of recording of usage of the supply.
NPL	Number of layers per pallet (GS1 Temporary Code) The number of layers per pallet.
NPP	Number of pallet places (GS1 Temporary Code) The number of pallet places needed to store or transport pallets (can be stacked).
OD	Outside diameter The measured outside diameter. GS1 Description: A measurement of the outside diameter of a roll, tube, pipe, or circle.
PMC	Package net measurement cube (GS1 Temporary Code) An indication of the net cubed measurement of a package.
PWF	Power factor (GS1 Temporary Code) The ration of the power dissipated (active power in kW) to the total power (which is the product of the input volts times amps given in kVa). When equipment which uses reactive power is being operated the power factor will be less than one.

Used Codes

RA	Relative humidity The measured relative humidity.
RJ	Rockwell C Hardness in the Rockwell C scale.
SF	Stacking factor excluding bottom item (GS1 Temporary Code) Maximum number of items stackable upon each other, excluding the bottom item.
SPG	Specific gravity (GS1 Temporary Code) The measured specific gravity.
SSZ	Step size (GS1 Temporary Code) An indication of measurements in which options contained within a Customer Specific Article are available, e.g. 10 metre planks of wood may be sold in step sizes of 2 metres.
T	Tare weight Weight excluding goods and loose accessories.
TC	Temperature A measurement in relation to temperature.
TH	Thickness The measured thickness.
TN	Time period Measurement of a specific length of time.
UCO	Units per package (GS1 Temporary Code) The number of identified units per package.
ULY	Number of units per layer (GS1 Temporary Code) Number of units of a product or package within one layer of a package, container, pallet, etc.
WD	Width dimension Numeric value of width.
WRM	Weight per running metre (GS1 Temporary Code) A code used to indicate the weight per running metre of floor coverings over floor area.
WSM	Weight per square metre (GS1 Temporary Code) A code used to indicate the weight per square metre of floor coverings over floor area.
X01	Acidity of meat (1 hour after slaughtering) The meat's acid quality or condition expressed as a pH value measured 1 hour after slaughtering.

Used Codes

X02	Acidity of meat (12 hours after slaughtering) The meat's acid quality or condition expressed as a pH value measured 12 hours after slaughtering.
X03	Acidity of meat (24 hours after slaughtering) The meat's acid quality or condition expressed as a pH value measured 24 hours after slaughtering.
X04	Acidity of meat (36 hour(s) after slaughtering) The meat's acid quality or condition expressed as a pH value measured 36 hours after slaughtering.
X05	Acidity of meat (48 hour(s) after slaughtering) The meat's acid quality or condition expressed as a pH value measured 48 hours after slaughtering.
X13	Acidity of meat (GS1 Temporary Code) The meat's acid quality or condition expressed as a pH value.
X16	Slaughtering weight (GS1 Temporary Code) Warm weight after slaughter
X17	Stacking factor including bottom item (GS1 Temporary Code) Maximum number of items stackable upon each other, including the bottom item.
X1E	Number of units in the width of a layer (GS1 Temporary Code) Number of units of a product or package which make up the width of a layer in a package, container, pallet, etc.
X2E	Number of units in the depth of a layer (GS1 Temporary Code) Number of units of a product or package which make up the depth of a layer in a package, container, pallet, etc.
X6E	Nestable percentage (GS1 Temporary Code) Extent expressed as a percentage to which an item can be nested within an identical item.
X7E	Gross weight including carrier's equipment (GS1 Temporary Code) Weight (mass) of goods including packaging and the carrier's equipment. In this context 'carrier's equipment' means any material resources necessary to facilitate the transport and handling of the goods without having the ability to move by its own propulsion, e.g. pallet, container, etc. GS1 usage Note The field of implementation of this code is the area of transport and related activities such as the preparation of goods into consignments for shipping.
ZWA	Waste content The measured waste content.
6321	Measurement significance code Code specifying the significance of a measurement.

Used Codes

3	Approximately The measurement is approximately equal to that specified.
4	Equal to The measurement is equal to that specified.
5	Greater than or equal to The measurement is greater than or equal to that specified.
6	Greater than The measurement is greater than that specified.
7	Less than The measurement is less than that specified.
8	Less than or equal to The measurement is less than or equal to that specified.
12	True value The measurement reported is a true value.
6343	Currency type code qualifier Code qualifying the type of currency.
1	Customs valuation currency The name or symbol of the monetary unit involved in the transaction for customs valuation.
3	Home currency The name or symbol of the local monetary unit.
4	Invoicing currency The name or symbol of the monetary unit used for calculation in an invoice.
5	Account currency The name or symbol of the monetary unit to be converted from.
8	Price list currency The name or symbol of the monetary unit used in a price list.
9	Order currency The name or symbol of the monetary unit used in an order.
10	Pricing currency The name or symbol of the monetary unit used for pricing purposes.
11	Payment currency The name or symbol of the monetary unit used for payment.
12	Quotation currency The name or symbol of the monetary unit used in a quotation.

Used Codes

13	Recipient local currency The name or symbol of the local monetary unit at recipient's location.
14	Supplier currency The name or symbol of the monetary unit normally used by the supplier.
15	Sender local currency The name or symbol of the local monetary unit at sender's location.
17	Charge calculation currency The currency in which the charges are calculated.
18	Tax currency The currency in which tax amounts are due or have been paid. EDIFACT
6345	Currency identification code Code specifying a monetary unit. Notes: 1. Use ISO 4217 three alpha code.
AED	Dirham
AFN	Afghani
ALL	Lek
AMD	Dram
ANG	Netherlands Antillian Guilder
AOA	Kwanza
ARS	Argentine Peso
AUD	Australian Dollar
AWG	Aruban Florin
AZN	Azerbaijan Manat
BAM	Convertible Mark
BBD	Barbados Dollar
BDT	Taka
BGN	Bulgarian Lev
BHD	Bahraini Dinar
BIF	Burundi Franc
BMD	Bermudian Dollar (customarily: Bermuda Dollar)
BND	Brunei Dollar
BOB	Boliviano

Used Codes

BOV	Mvdol
BRL	Brazilian Real
BSD	Bahamian Dollar
BTN	Ngultrum
BWP	Pula
BYN	Belarussian Ruble
BZD	Belize Dollar
CAD	Canadian Dollar
CDF	Franc Congolais
CHE	WIR Euro
CHF	Swiss Franc
CHW	WIR Franc
CLF	Unidad de Fomento
CLP	Chilean Peso
CNY	Yuan Renminbi
COP	Colombian Peso
COU	Unidad de Valor Real
CRC	Costa Rican Colon
CUC	Peso Convertible
CUP	Cuban Peso
CVE	Cabo Verde Escudo
CZK	Czech Koruna
DJF	Djibouti Franc
DKK	Danish Krone
DOP	Dominican Peso
DZD	Algerian Dinar
EGP	Egyptian Pound
ERN	Nakfa
ETB	Ethopian Birr
EUR	Euro
FJD	Fiji Dollar
FKP	Falkland Islands Pound
GBP	Pound Sterling

Used Codes

GEL	Lari
GHS	Ghana Cedi
GIP	Gibraltar Pound
GMD	Dalasi
GNF	Guinean Franc
GTQ	Quetzal
GYP	Guyana Dollar
HKD	Honk Kong Dollar
HNL	Lempira
HRK	Kuna
HTG	Gourde
HUF	Forint
IDR	Rupiah
ILS	New Israeli Sheqel
INR	Indian Rupee
IQD	Iraqi Dinar
IRR	Iranian Rial
ISK	Iceland Krona
JMD	Jamaican Dollar
JOD	Jordanian Dinar
JPY	Yen
KES	Kenyan Shilling
KGS	Som
KHR	Riel
KMF	Comorian Franc
KPW	North Korean Won
KRW	Won
KWD	Kuwaiti Dinar
KYD	Cayman Islands Dollar
KZT	Tenge
LAK	Lao Kip
LBP	Lebanese Pound
LKR	Sri Lanka Rupee

Used Codes

LRD	Liberian Dollar
LSL	Loti
LYD	Libyan Dinar
MAD	Morrocan Dirham
MDL	Moldovan Leu
MGA	Ariary
MKD	Denar
MMK	Kyat
MNT	Tugrik
MOP	Pataca
MRU	Ouguiya
MUR	Mauritius Rupee
MVR	Rufiyaa
MWK	Malawi Kwacha
MXN	Mexican Peso
MXV	Mexican Unidad de Inversion (UDI)
MYR	Malaysian Ringgit
MZN	Mozambique Metical
NAD	Namibia Dollar
NGN	Naira
NIO	Cordoba Oro
NOK	Norwegian Krone
NPR	Nepalese Rupee
NZD	New Zealand Dollar
OMR	Rial Omani
PAB	Balboa
PEN	Sol
PGK	Kina
PHP	Philippine Piso
PKR	Pakistan Rupee
PLN	Zloty
PYG	Guarani
QAR	Qatari Rial

Used Codes

RON	Romanian Leu This currency code is effective from 1 July 2005
RSD	Serbian Dinar
RUB	Russian Ruble
RWF	Rwanda Franc
SAR	Saudi Riyal
SBD	Solomon Islands Dollar
SCR	Seychelles Rupee
SDG	Sudanese Pound
SEK	Swedish Krona
SGD	Singapore Dollar
SHP	St. Helena Pound
SLL	Leone
SOS	Somali Shilling
SRD	Suriname Dollar
SSP	South Sudanese Pound
STN	Dobra
SVC	El Salvador Colon
SYP	Syrian Pound
SZL	Lilangeni
THB	Baht
TJS	Somoni
TMT	Turkmenistan New Manat
TND	Tunisian Dinar
TOP	Pa'anga
TRY	Turkish Lira
TTD	Trinidad and Tobago Dollar
TWD	New Taiwan Dollar
TZS	Tanzanian Shilling
UAH	Hryvnia
UGX	Uganda Shilling
USD	US Dollar
USN	US Dollar (Next day)

Used Codes

UYI	Uruguayo Peso en Unidades
UYU	Peso Uruguayo
UYW	Unidad Previsional
UZS	Uzbekistan Sum
VES	Bolívar Soberano
VND	Dong
VUV	Vatu
WST	Tala
XAF	CFA Franc
XAG	Silver
XAU	Gold
XBA	Bond Markets Units European Composite Unit (EURCO)
XBB	European Monetary Unit (E.M.U.-6)
XBC	European Unit of Account 9 (E.U.A.-9)
XBD	European Unit of Account 17 (E.U.A.-17)
XCD	East Carribean Dollar
XDR	SDR
XOF	CFA Franc
XPD	Palladium
XPF	CFP Franc
XPT	Platinum
XSU	Sucre
XTS	Codes specifically reserved for testing purposes
XUA	ADB Unit of Account
XXX	The codes assigned for transactions where no currency is involved
YER	Yemeni Rial
ZAR	Rand
ZMW	Zambian Kwacha
ZWL	Zimbabwe Dollar (effective 1 February 2009)

6347

Currency usage code qualifier
Code qualifying the usage of a currency.

Used Codes

2	Reference currency The currency applicable to amounts stated. It may have to be converted.
3	Target currency The currency which should be used to the target destination of the transaction.
6411	Measurement unit code Code specifying the unit of measurement. Notes: 1. Recommend use UN/ECE Recommendation 20, Common code.
10	group A unit of count defining the number of groups (group: set of items classified together).
11	outfit A unit of count defining the number of outfits (outfit: a complete set of equipment / materials / objects used for a specific purpose).
13	ration A unit of count defining the number of rations (ration: a single portion of provisions).
14	shot A unit of liquid measure, especially related to spirits.
15	stick, military A unit of count defining the number of military sticks (military stick: bombs or paratroops released in rapid succession from an aircraft).
20	twenty foot container A unit of count defining the number of shipping containers that measure 20 foot in length.
21	forty foot container A unit of count defining the number of shipping containers that measure 40 foot in length.
22	decilitre per gram
23	gram per cubic centimetre
24	theoretical pound A unit of mass defining the expected mass of material expressed as the number of pounds.
25	gram per square centimetre
27	theoretical ton A unit of mass defining the expected mass of material, expressed as the number of tons.
28	kilogram per square metre

Used Codes

33	kilopascal square metre per gram
34	kilopascal per millimetre
35	millilitre per square centimetre second
37	ounce per square foot
38	ounce per square foot per 0,01inch
40	millilitre per second
41	millilitre per minute
56	sitas A unit of area for tin plate equal to a surface area of 100 square metres.
57	mesh A unit of count defining the number of strands per inch as a measure of the fineness of a woven product.
58	net kilogram A unit of mass defining the total number of kilograms after deductions.
59	part per million A unit of proportion equal to 10 to the power of -6.
60	percent weight A unit of proportion equal to 10 to the power of -2.
61	part per billion (US) A unit of proportion equal to 10 to the power of -9.
64	pound per square inch, gauge
66	oersted
74	millipascal
76	gauss
77	milli-inch
78	kilogauss
80	pound per square inch absolute
81	henry
84	kilopound-force per square inch A unit of pressure defining the number of kilopounds force per square inch. Use kip per square inch (common code N20).
85	foot pound-force
87	pound per cubic foot
89	poise
91	stokes

Used Codes

1I	fixed rate A unit of quantity expressed as a predetermined or set rate for usage of a facility or service.
2A	radian per second Refer ISO/TC12 SI Guide
2B	radian per second squared Refer ISO/TC12 SI Guide
2C	roentgen
2G	volt AC A unit of electric potential in relation to alternating current (AC).
2H	volt DC A unit of electric potential in relation to direct current (DC).
2I	British thermal unit (international table) per hour
2J	cubic centimetre per second
2K	cubic foot per hour
2L	cubic foot per minute
2M	centimetre per second
2N	decibel
2P	kilobyte A unit of information equal to 10 to the power of 3 (1000) bytes.
2Q	kilobecquerel
2R	kilocurie
2U	megagram
2X	metre per minute
2Y	milliroentgen
2Z	millivolt
3B	megajoule
3C	manmonth A unit of count defining the number of months for a person or persons to perform an undertaking.
4C	centistokes
4G	microlitre
4H	micrometre (micron)
4K	milliampere

Used Codes

4L	megabyte A unit of information equal to 10 to the power of 6 (1000000) bytes.
4M	milligram per hour
4N	megabecquerel
4O	microfarad
4P	newton per metre
4Q	ounce inch
4R	ounce foot
4T	picofarad
4U	pound per hour
4W	ton (US) per hour
4X	kilolitre per hour
5A	barrel (US) per minute
5B	batch A unit of count defining the number of batches (batch: quantity of material produced in one operation or number of animals or persons coming at once).
5E	MMSCF/day A unit of volume equal to one million (1000000) cubic feet of gas per day.
5J	hydraulic horse power A unit of power defining the hydraulic horse power delivered by a fluid pump depending on the viscosity of the fluid.
A1	15 °C calorie
A10	ampere square metre per joule second
A11	angstrom
A12	astronomical unit
A13	attojoule
A14	barn
A15	barn per electronvolt
A16	barn per steradian electronvolt
A17	barn per steradian
A18	becquerel per kilogram
A19	becquerel per cubic metre
A2	ampere per centimetre
A20	British thermal unit (international table) per second square foot degree Rankine

Used Codes

A21	British thermal unit (international table) per pound degree Rankine
A22	British thermal unit (international table) per second foot degree Rankine
A23	British thermal unit (international table) per hour square foot degree Rankine
A24	candela per square metre
A25	cheval vapeur Synonym: metric horse power
A26	coulomb metre
A27	coulomb metre squared per volt
A28	coulomb per cubic centimetre
A29	coulomb per cubic metre
A3	ampere per millimetre
A30	coulomb per cubic millimetre
A31	coulomb per kilogram second
A32	coulomb per mole
A33	coulomb per square centimetre
A34	coulomb per square metre
A35	coulomb per square millimetre
A36	cubic centimetre per mole
A37	cubic decimetre per mole
A38	cubic metre per coulomb
A39	cubic metre per kilogram
A4	ampere per square centimetre
A40	cubic metre per mole
A41	ampere per square metre
A42	curie per kilogram
A43	deadweight tonnage A unit of mass defining the difference between the weight of a ship when completely empty and its weight when completely loaded, expressed as the number of tons.
A44	decalitre
A45	decametre
A47	decitex A unit of yarn density. One decitex equals a mass of 1 gram per 10 kilometres of length.

Used Codes

A48	degree Rankine Refer ISO 80000-5 (Quantities and units — Part 5: Thermodynamics)
A49	denier A unit of yarn density. One denier equals a mass of 1 gram per 9 kilometres of length.
A5	ampere square metre
A50	dyne second per cubic centimetre
A51	dyne second per centimetre
A52	dyne second per centimetre to the fifth power
A53	electronvolt
A54	electronvolt per metre
A55	electronvolt square metre
A56	electronvolt square metre per kilogram
A57	erg
A58	erg per centimetre
A59	8-part cloud cover A unit of count defining the number of eighth-parts as a measure of the celestial dome cloud coverage. Synonym: OKTA , OCTA
A6	ampere per square metre kelvin squared
A60	erg per cubic centimetre
A61	erg per gram
A62	erg per gram second
A63	erg per second
A64	erg per second square centimetre
A65	erg per square centimetre second
A66	erg square centimetre
A67	erg square centimetre per gram
A68	exajoule
A69	farad per metre
A7	ampere per square millimetre
A70	femtojoule
A71	femtometre
A73	foot per second squared
A74	foot pound-force per second

Used Codes

A75	freight ton A unit of information typically used for billing purposes, defined as either the number of metric tons or the number of cubic metres, whichever is the larger.
A76	gal
A77	Gaussian CGS (Centimetre-Gram-Second system) unit of displacement
A78	Gaussian CGS (Centimetre-Gram-Second system) unit of electric current
A79	Gaussian CGS (Centimetre-Gram-Second system) unit of electric charge
A8	ampere second
A80	Gaussian CGS (Centimetre-Gram-Second system) unit of electric field strength
A81	Gaussian CGS (Centimetre-Gram-Second system) unit of electric polarization
A82	Gaussian CGS (Centimetre-Gram-Second system) unit of electric potential
A83	Gaussian CGS (Centimetre-Gram-Second system) unit of magnetization
A84	gigacoulomb per cubic metre
A85	gigaelectronvolt
A86	gigahertz
A87	gigaohm
A88	gigaohm metre
A89	gigapascal
A9	rate A unit of quantity expressed as a rate for usage of a facility or service.
A90	gigawatt
A91	gon Synonym: grade
A93	gram per cubic metre
A94	gram per mole
A95	gray
A96	gray per second
A97	hectopascal
A98	henry per metre
A99	bit A unit of information equal to one binary digit.
AA	ball A unit of count defining the number of balls (ball: object formed in the shape of sphere).

Used Codes

AB	bulk pack A unit of count defining the number of items per bulk pack.
ACR	acre
ACT	activity A unit of count defining the number of activities (activity: a unit of work or action).
AD	byte A unit of information equal to 8 bits.
AE	ampere per metre
AH	additional minute A unit of time defining the number of minutes in addition to the referenced minutes.
AI	average minute per call A unit of count defining the number of minutes for the average interval of a call.
AK	fathom
AL	access line A unit of count defining the number of telephone access lines.
AMH	ampere hour A unit of electric charge defining the amount of charge accumulated by a steady flow of one ampere for one hour.
AMP	ampere
ANN	year Unit of time equal to 365,25 days. Synonym: Julian year
APZ	troy ounce or apothecary ounce
AQ	anti-hemophilic factor (AHF) unit A unit of measure for blood potency (US).
ARE	are Synonym: square decametre
AS	assortment A unit of count defining the number of assortments (assortment: set of items grouped in a mixed collection).
ASM	alcoholic strength by mass A unit of mass defining the alcoholic strength of a liquid.
ASU	alcoholic strength by volume A unit of volume defining the alcoholic strength of a liquid (e.g. spirit, wine, beer, etc), often at a specific temperature.

Used Codes

ATM	standard atmosphere
ATT	technical atmosphere
AWG	american wire gauge A unit of distance used for measuring the diameter of small tubes or wires such as the outer diameter of hypotermic or suture needles.
AY	assembly A unit of count defining the number of assemblies (assembly: items that consist of component parts).
AZ	British thermal unit (international table) per pound
B1	barrel (US) per day
B10	bit per second A unit of information equal to one binary digit per second.
B11	joule per kilogram kelvin
B12	joule per metre
B13	joule per square metre Synonym: joule per metre squared
B14	joule per metre to the fourth power
B15	joule per mole
B16	joule per mole kelvin
B17	credit A unit of count defining the number of entries made to the credit side of an account.
B18	joule second
B19	digit A unit of information defining the quantity of numerals used to form a number.
B20	joule square metre per kilogram
B21	kelvin per watt
B22	kiloampere
B23	kiloampere per square metre
B24	kiloampere per metre
B25	kilobecquerel per kilogram
B26	kilocoulomb
B27	kilocoulomb per cubic metre
B28	kilocoulomb per square metre
B29	kiloelectronvolt

Used Codes

B3	batting pound A unit of mass defining the number of pounds of wadded fibre.
B30	gibibit A unit of information equal to 2 ³⁰ bits (binary digits).
B31	kilogram metre per second
B32	kilogram metre squared
B33	kilogram metre squared per second
B34	kilogram per cubic decimetre
B35	kilogram per litre
B36	calorie (thermochemical) per gram
B37	kilogram-force
B38	kilogram-force metre
B39	kilogram-force metre per second
B4	barrel, imperial A unit of volume used to measure beer. One beer barrel equals 36 imperial gallons.
B40	kilogram-force per square metre
B41	kilojoule per kelvin
B42	kilojoule per kilogram
B43	kilojoule per kilogram kelvin
B44	kilojoule per mole
B45	kilomole
B46	kilomole per cubic metre
B47	kilonewton
B48	kilonewton metre
B49	kiloohm
B50	kiloohm metre
B51	kilopond Synonym: kilogram-force
B52	kilosecond
B53	kilosiemens
B54	kilosiemens per metre
B55	kilovolt per metre
B56	kiloweber per metre

Used Codes

B57	light year A unit of length defining the distance that light travels in a vacuum in one year.
B58	litre per mole
B59	lumen hour
B60	lumen per square metre
B61	lumen per watt
B62	lumen second
B63	lux hour
B64	lux second
B65	maxwell
B66	megaampere per square metre
B67	megabecquerel per kilogram
B68	gigabit A unit of information equal to 10 to the power of 9 bits (binary digits).
B69	megacoulomb per cubic metre
B7	cycle A unit of count defining the number of cycles (cycle: a recurrent period of definite duration).
B70	megacoulomb per square metre
B71	megaelectronvolt
B72	megagram per cubic metre
B73	meganewton
B74	meganewton metre
B75	megaohm
B76	megaohm metre
B77	megasiemens per metre
B78	megavolt
B79	megavolt per metre
B8	joule per cubic metre
B80	gigabit per second A unit of information equal to 10 to the power of 9 bits (binary digits) per second.
B81	reciprocal metre squared reciprocal second

Used Codes

B82	inch per linear foot A unit of length defining the number of inches per linear foot.
B83	metre to the fourth power
B84	microampere
B85	microbar
B86	microcoulomb
B87	microcoulomb per cubic metre
B88	microcoulomb per square metre
B89	microfarad per metre
B90	microhenry
B91	microhenry per metre
B92	micronewton
B93	micronewton metre
B94	microohm
B95	microohm metre
B96	micropascal
B97	microradian
B98	microsecond
B99	microsiemens
BAR	bar [unit of pressure]
BB	base box A unit of area of 112 sheets of tin mil products (tin plate, tin free steel or black plate) 14 by 20 inches, or 31,360 square inches.
BFT	board foot A unit of volume defining the number of cords (cord: a stack of firewood of 128 cubic feet).
BHP	brake horse power
BIL	billion (EUR) Synonym: trillion (US)
BLD	dry barrel (US)
BLL	barrel (US)
BP	hundred board foot A unit of volume equal to one hundred board foot.
BPM	beats per minute The number of beats per minute.

Used Codes

BQL	becquerel
BTU	British thermal unit (international table)
BUA	bushel (US)
BUI	bushel (UK)
C0	call A unit of count defining the number of calls (call: communication session or visitation).
C10	millifarad
C11	milligal
C12	milligram per metre
C13	milligray
C14	millihenry
C15	millijoule
C16	millimetre per second
C17	millimetre squared per second
C18	millimole
C19	mole per kilogram
C20	millinewton
C21	kibibit A unit of information equal to 2 to the power of 10 (1024) bits (binary digits).
C22	millinewton per metre
C23	milliohm metre
C24	millipascal second
C25	milliradian
C26	millisecond
C27	millisiemens
C28	millisievert
C29	millitesla
C3	microvolt per metre
C30	millivolt per metre
C31	milliwatt
C32	milliwatt per square metre
C33	milliweber
C34	mole

Used Codes

C35	mole per cubic decimetre
C36	mole per cubic metre
C37	kilobit A unit of information equal to 10 to the power of 3 (1000) bits (binary digits).
C38	mole per litre
C39	nanoampere
C40	nanocoulomb
C41	nanofarad
C42	nanofarad per metre
C43	nanohenry
C44	nanohenry per metre
C45	nanometre
C46	nanoohm metre
C47	nanosecond
C48	nanotesla
C49	nanowatt
C50	neper
C51	neper per second
C52	picometre
C53	newton metre second
C54	newton metre squared per kilogram squared
C55	newton per square metre
C56	newton per square millimetre
C57	newton second
C58	newton second per metre
C59	octave A unit used in music to describe the ratio in frequency between notes.
C60	ohm centimetre
C61	ohm metre
C62	one Synonym: unit
C63	parsec
C64	pascal per kelvin
C65	pascal second

Used Codes

C66	pascal second per cubic metre
C67	pascal second per metre
C68	petajoule
C69	phon A unit of subjective sound loudness. A sound has loudness p phons if it seems to the listener to be equal in loudness to the sound of a pure tone of frequency 1 kilohertz and strength p decibels.
C7	centipoise
C70	picoampere
C71	picocoulomb
C72	picofarad per metre
C73	picohenry
C74	kilobit per second A unit of information equal to 10 to the power of 3 (1000) bits (binary digits) per second.
C75	picowatt
C76	picowatt per square metre
C78	pound-force
C79	kilovolt ampere hour A unit of accumulated energy of 1000 volt amperes over a period of one hour.
C8	millicoulomb per kilogram
C80	rad
C81	radian
C82	radian square metre per mole
C83	radian square metre per kilogram
C84	radian per metre
C85	reciprocal angstrom
C86	reciprocal cubic metre
C87	reciprocal cubic metre per second Synonym: reciprocal second per cubic metre
C88	reciprocal electron volt per cubic metre
C89	reciprocal henry
C9	coil group A unit of count defining the number of coil groups (coil group: groups of items arranged by lengths of those items placed in a joined sequence of concentric circles).

Used Codes

C90	reciprocal joule per cubic metre
C91	reciprocal kelvin or kelvin to the power minus one
C92	reciprocal metre
C93	reciprocal square metre Synonym: reciprocal metre squared
C94	reciprocal minute
C95	reciprocal mole
C96	reciprocal pascal or pascal to the power minus one
C97	reciprocal second
C99	reciprocal second per metre squared
CCT	carrying capacity in metric ton A unit of mass defining the carrying capacity, expressed as the number of metric tons.
CDL	candela
CEL	degree Celsius Refer ISO 80000-5 (Quantities and units – Part 5: Thermodynamics)
CEN	hundred A unit of count defining the number of units in multiples of 100.
CG	card A unit of count defining the number of units of card (card: thick stiff paper or cardboard).
CGM	centigram
CKG	coulomb per kilogram
CLF	hundred leave A unit of count defining the number of leaves, expressed in units of one hundred leaves.
CLT	centilitre
CMK	square centimetre
CMQ	cubic centimetre
CMT	centimetre
CNP	hundred pack A unit of count defining the number of hundred-packs (hundred-pack: set of one hundred items packaged together).
CNT	cental (UK) A unit of mass equal to one hundred weight (US).
COU	coulomb

Used Codes

CTG	content gram A unit of mass defining the number of grams of a named item in a product.
CTM	metric carat
CTN	content ton (metric) A unit of mass defining the number of metric tons of a named item in a product.
CUR	curie
CWA	hundred pound (cwt) / hundred weight (US)
CWI	hundred weight (UK)
D03	kilowatt hour per hour A unit of accumulated energy of a thousand watts over a period of one hour.
D04	lot [unit of weight] A unit of weight equal to about 1/2 ounce or 15 grams.
D1	reciprocal second per steradian
D10	siemens per metre
D11	mebibit A unit of information equal to 2 to the power of 20 (1048576) bits (binary digits).
D12	siemens square metre per mole
D13	sievert
D15	sone A unit of subjective sound loudness. One sone is the loudness of a pure tone of frequency one kilohertz and strength 40 decibels.
D16	square centimetre per erg
D17	square centimetre per steradian erg
D18	metre kelvin
D19	square metre kelvin per watt
D2	reciprocal second per steradian metre squared
D20	square metre per joule
D21	square metre per kilogram
D22	square metre per mole
D23	pen gram (protein) A unit of count defining the number of grams of amino acid prescribed for parenteral/enteral therapy.
D24	square metre per steradian
D25	square metre per steradian joule

Used Codes

D26	square metre per volt second
D27	steradian
D29	terahertz
D30	terajoule
D31	terawatt
D32	terawatt hour
D33	tesla
D34	tex A unit of yarn density. One decitex equals a mass of 1 gram per 1 kilometre of length.
D35	calorie (thermochemical)
D36	megabit A unit of information equal to 10 to the power of 6 (1000000) bits (binary digits).
D37	calorie (thermochemical) per gram kelvin
D38	calorie (thermochemical) per second centimetre kelvin
D39	calorie (thermochemical) per second square centimetre kelvin
D41	tonne per cubic metre
D42	tropical year
D43	unified atomic mass unit
D44	var The name of the unit is an acronym for volt-ampere-reactive.
D45	volt squared per kelvin squared
D46	volt - ampere
D47	volt per centimetre
D48	volt per kelvin
D49	millivolt per kelvin
D5	kilogram per square centimetre
D50	volt per metre
D51	volt per millimetre
D52	watt per kelvin
D53	watt per metre kelvin
D54	watt per square metre
D55	watt per square metre kelvin
D56	watt per square metre kelvin to the fourth power

Used Codes

D57	watt per steradian
D58	watt per steradian square metre
D59	weber per metre
D6	roentgen per second
D60	weber per millimetre
D61	minute [unit of angle]
D62	second [unit of angle]
D63	book A unit of count defining the number of books (book: set of items bound together or written document of a material whole).
D65	round A unit of count defining the number of rounds (round: A circular or cylindrical object).
D68	number of words A unit of count defining the number of words.
D69	inch to the fourth power
D70	calorie (international table)
D71	calorie (international table) per second centimetre kelvin
D72	calorie (international table) per second square centimetre kelvin
D73	joule square metre
D74	kilogram per mole
D75	calorie (international table) per gram
D76	calorie (international table) per gram kelvin
D77	megacoulomb
D78	megajoule per second A unit of accumulated energy equal to one million joules per second.
D80	microwatt
D81	microtesla
D82	microvolt
D83	millinewton metre
D85	microwatt per square metre
D86	millicoulomb
D87	millimole per kilogram
D88	millicoulomb per cubic metre
D89	millicoulomb per square metre

Used Codes

D9	dyne per square centimetre
D91	rem
D93	second per cubic metre
D94	second per cubic metre radian
D95	joule per gram
DAA	decare
DAD	ten day A unit of time defining the number of days in multiples of 10.
DAY	day
DB	dry pound A unit of mass defining the number of pounds of a product, disregarding the water content of the product.
DBM	Decibel-milliwatts dBm (sometimes dBmW or decibel-milliwatts) is unit of level used to indicate that a power ratio is expressed in decibels (dB) with reference to one milliwatt (mW).
DBW	Decibel watt The decibel watt or dBW is a unit for the measurement of the strength of a signal expressed in decibels relative to one watt.
DD	degree [unit of angle]
DEC	decade A unit of count defining the number of decades (decade: quantity equal to 10 or time equal to 10 years).
DG	decigram
DJ	decagram
DLT	decilitre
DMA	cubic decametre
DMK	square decimetre
DMO	standard kilolitre A unit of volume defining the number of kilolitres of a product at a temperature of 15 degrees Celsius, especially in relation to hydrocarbon oils.
DMQ	cubic decimetre
DMT	decimetre
DN	decinewton metre
DPC	dozen piece A unit of count defining the number of pieces in multiples of 12 (piece: a single item, article or exemplar).

Used Codes

DPR	dozen pair A unit of count defining the number of pairs in multiples of 12 (pair: item described by two's).
DPT	displacement tonnage A unit of mass defining the volume of sea water a ship displaces, expressed as the number of tons.
DRA	dram (US) Synonym: drachm (UK), troy dram
DRI	dram (UK) Synonym: avoirdupois dram
DRL	dozen roll A unit of count defining the number of rolls, expressed in twelve roll units.
DT	dry ton A unit of mass defining the number of tons of a product, disregarding the water content of the product.
DTN	decitonne Synonym: centner, metric 100 kg, quintal, metric 100 kg
DU	dyne
DWT	pennyweight
DX	dyne per centimetre
DZN	dozen A unit of count defining the number of units in multiples of 12.
DZP	dozen pack A unit of count defining the number of packs in multiples of 12 (pack: standard packaging unit).
E01	newton per square centimetre A measure of pressure expressed in newtons per square centimetre.
E07	megawatt hour per hour A unit of accumulated energy of a million watts over a period of one hour.
E08	megawatt per hertz A unit of energy expressed as the load change in million watts that will cause a frequency shift of one hertz.
E09	milliampere hour A unit of power load delivered at the rate of one thousandth of an ampere over a period of one hour.
E10	degree day A unit of measure used in meteorology and engineering to measure the demand for heating or cooling over a given period of days.

Used Codes

E11	gigacalorie A unit of heat energy equal to one thousand million calories.
E12	mille A unit of count defining the number of cigarettes in units of 1000.
E14	kilocalorie (international table) A unit of heat energy equal to one thousand calories.
E15	kilocalorie (thermochemical) per hour A unit of energy equal to one thousand calories per hour.
E16	million Btu(IT) per hour A unit of power equal to one million British thermal units per hour.
E17	cubic foot per second A unit of volume equal to one cubic foot passing a given point in a period of one second.
E18	tonne per hour A unit of weight or mass equal to one tonne per hour.
E19	ping A unit of area equal to 3.3 square metres.
E20	megabit per second A unit of information equal to 10 to the power of 6 (1000000) bits (binary digits) per second.
E21	shares A unit of count defining the number of shares (share: a total or portion of the parts into which a business entity's capital is divided).
E22	TEU A unit of count defining the number of twenty-foot equivalent units (TEUs) as a measure of containerized cargo capacity.
E23	tyre A unit of count defining the number of tyres (a solid or air-filled covering placed around a wheel rim to form a soft contact with the road, absorb shock and provide traction).
E25	active unit A unit of count defining the number of active units within a substance.
E27	dose A unit of count defining the number of doses (dose: a definite quantity of a medicine or drug).
E28	air dry ton A unit of mass defining the number of tons of a product, disregarding the water content of the product.

Used Codes

E30	strand A unit of count defining the number of strands (strand: long, thin, flexible, single thread, strip of fibre, constituent filament or multiples of the same, twisted together).
E31	square metre per litre A unit of count defining the number of square metres per litre.
E32	litre per hour A unit of count defining the number of litres per hour.
E33	foot per thousand A unit of count defining the number of feet per thousand units.
E34	gigabyte A unit of information equal to 10 to the power of 9 bytes.
E35	terabyte A unit of information equal to 10 to the power of 12 bytes.
E36	petabyte A unit of information equal to 10 to the power of 15 bytes.
E37	pixel A unit of count defining the number of pixels (pixel: picture element).
E38	megapixel A unit of count equal to 10 to the power of 6 (1000000) pixels (picture elements).
E39	dots per inch A unit of information defining the number of dots per linear inch as a measure of the resolution or sharpness of a graphic image.
E4	gross kilogram A unit of mass defining the total number of kilograms before deductions.
E40	part per hundred thousand A unit of proportion equal to 10 to the power of -5.
E41	kilogram-force per square millimetre A unit of pressure defining the number of kilograms force per square millimetre.
E42	kilogram-force per square centimetre A unit of pressure defining the number of kilograms force per square centimetre.
E43	joule per square centimetre A unit of energy defining the number of joules per square centimetre.
E44	kilogram-force metre per square centimetre A unit of torsion defining the torque kilogram-force metre per square centimetre.

Used Codes

E45	milliohm
E46	kilowatt hour per cubic metre A unit of energy consumption expressed as kilowatt hour per cubic metre.
E47	kilowatt hour per kelvin A unit of energy consumption expressed as kilowatt hour per kelvin.
E48	service unit A unit of count defining the number of service units (service unit: defined period / property / facility / utility of supply).
E49	working day A unit of count defining the number of working days (working day: a day on which work is ordinarily performed).
E50	accounting unit A unit of count defining the number of accounting units.
E51	job A unit of count defining the number of jobs.
E52	run foot A unit of count defining the number feet per run.
E53	test A unit of count defining the number of tests.
E54	trip A unit of count defining the number of trips.
E55	use A unit of count defining the number of times an object is used.
E56	well A unit of count defining the number of wells.
E57	zone A unit of count defining the number of zones.
E58	exabit per second A unit of information equal to 10 to the power of 18 bits (binary digits) per second.
E59	exbibyte A unit of information equal to 2 to the power of 60 bytes.
E60	pebibyte A unit of information equal to 2 to the power of 50 bytes.
E61	tebibyte A unit of information equal to 2 to the power of 40 bytes.
E62	gibibyte A unit of information equal to 2 to the power of 30 bytes.

Used Codes

E63	mebibyte A unit of information equal to 2 to the power of 20 bytes.
E64	kibibyte A unit of information equal to 2 to the power of 10 bytes.
E65	exbibit per metre A unit of information equal to 2 to the power of 60 bits (binary digits) per metre.
E66	exbibit per square metre A unit of information equal to 2 to the power of 60 bits (binary digits) per square metre.
E67	exbibit per cubic metre A unit of information equal to 2 to the power of 60 bits (binary digits) per cubic metre.
E68	gigabyte per second A unit of information equal to 10 to the power of 9 bytes per second.
E69	gibibit per metre A unit of information equal to 2 to the power of 30 bits (binary digits) per metre.
E70	gibibit per square metre A unit of information equal to 2 to the power of 30 bits (binary digits) per square metre.
E71	gibibit per cubic metre A unit of information equal to 2 to the power of 30 bits (binary digits) per cubic metre.
E72	kibibit per metre A unit of information equal to 2 to the power of 10 bits (binary digits) per metre.
E73	kibibit per square metre A unit of information equal to 2 to the power of 10 bits (binary digits) per square metre.
E74	kibibit per cubic metre A unit of information equal to 2 to the power of 10 bits (binary digits) per cubic metre.
E75	mebibit per metre A unit of information equal to 2 to the power of 20 bits (binary digits) per metre.
E76	mebibit per square metre A unit of information equal to 2 to the power of 20 bits (binary digits) per square metre.

Used Codes

E77	mebibit per cubic metre A unit of information equal to 2 to the power of 20 bits (binary digits) per cubic metre.
E78	petabit A unit of information equal to 10 to the power of 15 bits (binary digits).
E79	petabit per second A unit of information equal to 10 to the power of 15 bits (binary digits) per second.
E80	pebibit per metre A unit of information equal to 2 to the power of 50 bits (binary digits) per metre.
E81	pebibit per square metre A unit of information equal to 2 to the power of 50 bits (binary digits) per square metre.
E82	pebibit per cubic metre A unit of information equal to 2 to the power of 50 bits (binary digits) per cubic metre.
E83	terabit A unit of information equal to 10 to the power of 12 bits (binary digits).
E84	terabit per second A unit of information equal to 10 to the power of 12 bits (binary digits) per second.
E85	tebibit per metre A unit of information equal to 2 to the power of 40 bits (binary digits) per metre.
E86	tebibit per cubic metre A unit of information equal to 2 to the power of 40 bits (binary digits) per cubic metre.
E87	tebibit per square metre A unit of information equal to 2 to the power of 40 bits (binary digits) per square metre.
E88	bit per metre A unit of information equal to 1 bit (binary digit) per metre.
E89	bit per square metre A unit of information equal to 1 bit (binary digit) per square metre.
E90	reciprocal centimetre
E91	reciprocal day
E92	cubic decimetre per hour
E93	kilogram per hour

Used Codes

E94	kilomole per second
E95	mole per second
E96	degree per second
E97	millimetre per degree Celcius metre
E98	degree Celsius per kelvin
E99	hectopascal per bar
EA	each A unit of count defining the number of items regarded as separate units.
EB	electronic mail box A unit of count defining the number of electronic mail boxes.
EQ	equivalent gallon A unit of volume defining the number of gallons of product produced from concentrate.
F01	bit per cubic metre A unit of information equal to 1 bit (binary digit) per cubic metre.
F02	kelvin per kelvin
F03	kilopascal per bar
F04	millibar per bar
F05	megapascal per bar
F06	poise per bar
F07	pascal per bar
F08	milliampere per inch
F10	kelvin per hour
F11	kelvin per minute
F12	kelvin per second
F13	slug A unit of mass. One slug is the mass accelerated at 1 foot per second per second by a force of 1 pound.
F14	gram per kelvin
F15	kilogram per kelvin
F16	milligram per kelvin
F17	pound-force per foot
F18	kilogram square centimetre
F19	kilogram square millimetre
F20	pound inch squared

Used Codes

F21	pound-force inch
F22	pound-force foot per ampere
F23	gram per cubic decimetre
F24	kilogram per kilomole
F25	gram per hertz
F26	gram per day
F27	gram per hour
F28	gram per minute
F29	gram per second
F30	kilogram per day
F31	kilogram per minute
F32	milligram per day
F33	milligram per minute
F34	milligram per second
F35	gram per day kelvin
F36	gram per hour kelvin
F37	gram per minute kelvin
F38	gram per second kelvin
F39	kilogram per day kelvin
F40	kilogram per hour kelvin
F41	kilogram per minute kelvin
F42	kilogram per second kelvin
F43	milligram per day kelvin
F44	milligram per hour kelvin
F45	milligram per minute kelvin
F46	milligram per second kelvin
F47	newton per millimetre
F48	pound-force per inch
F49	rod [unit of distance] A unit of distance equal to 5.5 yards (16 feet 6 inches).
F50	micrometre per kelvin
F51	centimetre per kelvin
F52	metre per kelvin

Used Codes

F53	millimetre per kelvin
F54	milliohm per metre
F55	ohm per mile (statute mile)
F56	ohm per kilometre
F57	milliampere per pound-force per square inch
F58	reciprocal bar
F59	milliampere per bar
F60	degree Celsius per bar
F61	kelvin per bar
F62	gram per day bar
F63	gram per hour bar
F64	gram per minute bar
F65	gram per second bar
F66	kilogram per day bar
F67	kilogram per hour bar
F68	kilogram per minute bar
F69	kilogram per second bar
F70	milligram per day bar
F71	milligram per hour bar
F72	milligram per minute bar
F73	milligram per second bar
F74	gram per bar
F75	milligram per bar
F76	milliampere per millimetre
F77	pascal second per kelvin
F78	inch of water
F79	inch of mercury
F80	water horse power A unit of power defining the amount of power required to move a given volume of water against acceleration of gravity to a specified elevation (pressure head).
F81	bar per kelvin
F82	hectopascal per kelvin
F83	kilopascal per kelvin

Used Codes

F84	millibar per kelvin
F85	megapascal per kelvin
F86	poise per kelvin
F87	volt per litre minute
F88	newton centimetre
F89	newton metre per degree
F90	newton metre per ampere
F91	bar litre per second
F92	bar cubic metre per second
F93	hectopascal litre per second
F94	hectopascal cubic metre per second
F95	millibar litre per second
F96	millibar cubic metre per second
F97	megapascal litre per second
F98	megapascal cubic metre per second
F99	pascal litre per second
FAH	degree Fahrenheit Refer ISO 80000-5 (Quantities and units — Part 5: Thermodynamics)
FAR	farad
FBM	fibre metre A unit of length defining the number of metres of individual fibre.
FC	thousand cubic foot A unit of volume equal to one thousand cubic foot.
FF	hundred cubic metre A unit of volume equal to one hundred cubic metres.
FH	micromole
FIT	failures in time A unit of count defining the number of failures that can be expected over a specified time interval. Failure rates of semiconductor components are often specified as FIT (failures in time unit) where 1 FIT = 10 to the power of -9 /h.
FL	flake ton A unit of mass defining the number of tons of a flaked substance (flake: a small flattish fragment).
FNU	Formazin nephelometric unit Formazin nephelometric unit (FNU) is used for water turbidity level evaluation
FOT	foot

Used Codes

FP	pound per square foot
FR	foot per minute
FS	foot per second
FTK	square foot
FTQ	cubic foot
G01	pascal cubic metre per second
G04	centimetre per bar
G05	metre per bar
G06	millimetre per bar
G08	square inch per second
G09	square metre per second kelvin
G10	stokes per kelvin
G11	gram per cubic centimetre bar
G12	gram per cubic decimetre bar
G13	gram per litre bar
G14	gram per cubic metre bar
G15	gram per millilitre bar
G16	kilogram per cubic centimetre bar
G17	kilogram per litre bar
G18	kilogram per cubic metre bar
G19	newton metre per kilogram
G2	US gallon per minute
G20	pound-force foot per pound
G21	cup [unit of volume]
G23	peck
G24	tablespoon (US)
G25	teaspoon (US)
G26	stere
G27	cubic centimetre per kelvin
G28	litre per kelvin
G29	cubic metre per kelvin
G3	Imperial gallon per minute
G30	millilitre per kelvin

Used Codes

G31	kilogram per cubic centimetre
G32	ounce (avoirdupois) per cubic yard
G33	gram per cubic centimetre kelvin
G34	gram per cubic decimetre kelvin
G35	gram per litre kelvin
G36	gram per cubic metre kelvin
G37	gram per millilitre kelvin
G38	kilogram per cubic centimetre kelvin
G39	kilogram per litre kelvin
G40	kilogram per cubic metre kelvin
G41	square metre per second bar
G42	microsiemens per centimetre
G43	microsiemens per metre
G44	nanosiemens per centimetre
G45	nanosiemens per metre
G46	stokes per bar
G47	cubic centimetre per day
G48	cubic centimetre per hour
G49	cubic centimetre per minute
G50	gallon (US) per hour
G51	litre per second
G52	cubic metre per day
G53	cubic metre per minute
G54	millilitre per day
G55	millilitre per hour
G56	cubic inch per hour
G57	cubic inch per minute
G58	cubic inch per second
G59	milliampere per litre minute
G60	volt per bar
G61	cubic centimetre per day kelvin
G62	cubic centimetre per hour kelvin
G63	cubic centimetre per minute kelvin

Used Codes

G64	cubic centimetre per second kelvin
G65	litre per day kelvin
G66	litre per hour kelvin
G67	litre per minute kelvin
G68	litre per second kelvin
G69	cubic metre per day kelvin
G70	cubic metre per hour kelvin
G71	cubic metre per minute kelvin
G72	cubic metre per second kelvin
G73	millilitre per day kelvin
G74	millilitre per hour kelvin
G75	millilitre per minute kelvin
G76	millilitre per second kelvin
G77	millimetre to the fourth power
G78	cubic centimetre per day bar
G79	cubic centimetre per hour bar
G80	cubic centimetre per minute bar
G81	cubic centimetre per second bar
G82	litre per day bar
G83	litre per hour bar
G84	litre per minute bar
G85	litre per second bar
G86	cubic metre per day bar
G87	cubic metre per hour bar
G88	cubic metre per minute bar
G89	cubic metre per second bar
G90	millilitre per day bar
G91	millilitre per hour bar
G92	millilitre per minute bar
G93	millilitre per second bar
G94	cubic centimetre per bar
G95	litre per bar
G96	cubic metre per bar

Used Codes

G97	millilitre per bar
G98	microhenry per kilohm
G99	microhenry per ohm
GB	gallon (US) per day
GBQ	gigabecquerel
GDW	gram, dry weight A unit of mass defining the number of grams of a product, disregarding the water content of the product.
GE	pound per gallon (US)
GF	gram per metre (gram per 100 centimetres)
GFI	gram of fissile isotope A unit of mass defining the number of grams of a fissile isotope (fissile isotope: an isotope whose nucleus is able to be split when irradiated with low energy neutrons).
GGR	great gross A unit of count defining the number of units in multiples of 1728 (12 x 12 x 12).
GIA	gill (US)
GIC	gram, including container A unit of mass defining the number of grams of a product, including its container.
GII	gill (UK)
GIP	gram, including inner packaging A unit of mass defining the number of grams of a product, including its inner packaging materials.
GJ	gram per millilitre
GL	gram per litre
GLD	dry gallon (US)
GLI	gallon (UK)
GLL	gallon (US)
GM	gram per square metre
GO	milligram per square metre
GP	milligram per cubic metre
GQ	microgram per cubic metre
GRM	gram
GRN	grain

Used Codes

GRO	gross A unit of count defining the number of units in multiples of 144 (12 x 12).
GRT	gross register ton A unit of mass equal to the total cubic footage before deductions, where 1 register ton is equal to 100 cubic feet. Refer International Convention on tonnage measurement of ships.
GT	gross ton A unit of mass equal to 2240 pounds. Refer International Convention on Tonnage measurement of Ships. Synonym: ton (UK) or long ton (US) (common code LTN)
GV	gigajoule
GWH	gigawatt hour
H03	henry per kilohm
H04	henry per ohm
H05	millihenry per kilohm
H06	millihenry per ohm
H07	pascal second per bar
H08	microbecquerel
H09	reciprocal year
H10	reciprocal hour
H11	reciprocal month
H12	degree Celsius per hour
H13	degree Celsius per minute
H14	degree Celsius per second
H15	square centimetre per gram
H16	square decametre Synonym: are
H18	square hectometre Synonym: hectare
H19	cubic hectometre
H20	cubic kilometre
H21	blank A unit of count defining the number of blanks.
H22	volt square inch per pound-force
H23	volt per inch
H24	volt per microsecond

Used Codes

H25	percent per kelvin A unit of proportion, equal to 0.01, in relation to the SI base unit Kelvin.
H26	ohm per metre
H27	degree per metre
H28	microfarad per kilometre
H29	microgram per litre
H30	square micrometre (square micron)
H31	ampere per kilogram
H32	ampere squared second
H33	farad per kilometre
H34	hertz metre
H35	kelvin metre per watt
H36	megaohm per kilometre
H37	megaohm per metre
H38	megaampere
H39	megahertz kilometre
H40	newton per ampere
H41	newton metre watt to the power minus 0,5
H42	pascal per metre
H43	siemens per centimetre
H44	teraohm
H45	volt second per metre
H46	volt per second
H47	watt per cubic metre
H48	attofarad
H49	centimetre per hour
H50	reciprocal cubic centimetre
H51	decibel per kilometre
H52	decibel per metre
H53	kilogram per bar
H54	kilogram per cubic decimetre kelvin
H55	kilogram per cubic decimetre bar
H56	kilogram per square metre second

Used Codes

H57	inch per two pi radiant
H58	metre per volt second
H59	square metre per newton
H60	cubic metre per cubic metre
H61	millisiemens per centimetre
H62	millivolt per minute
H63	milligram per square centimetre
H64	milligram per gram
H65	millilitre per cubic metre
H66	millimetre per year
H67	millimetre per hour
H68	millimole per gram
H69	picopascal per kilometre
H70	picosecond
H71	percent per month A unit of proportion, equal to 0.01, in relation to a month.
H72	percent per hectobar A unit of proportion, equal to 0.01, in relation to 100-fold of the unit bar.
H73	percent per decakelvin A unit of proportion, equal to 0.01, in relation to 10-fold of the SI base unit Kelvin.
H74	watt per metre
H75	decapascal
H76	gram per millimetre
H77	module width A unit of measure used to describe the breadth of electronic assemblies as an installation standard or mounting dimension.
H78	conventional centimetre of water
H79	Charrière A unit of distance used for measuring the diameter of small tubes such as urological instruments and catheters. Synonym: French, French gauge, Charrière gauge
H80	rack unit A unit of measure used to describe the height in rack units of equipment intended for mounting in a 19-inch rack or a 23-inch rack. One rack unit is 1.75 inches (44.45 mm) high.
H81	millimetre per minute

Used Codes

H82	big point A unit of length defining the number of big points (big point: Adobe software(US) defines the big point to be exactly 1/72 inch (0.013 888 9 inch or 0.352 777 8 millimeters))
H83	litre per kilogram
H84	gram millimetre
H85	reciprocal week
H87	piece A unit of count defining the number of pieces (piece: a single item, article or exemplar).
H88	megaohm kilometre
H89	percent per ohm A unit of proportion, equal to 0.01, in relation to the SI derived unit ohm.
H90	percent per degree A unit of proportion, equal to 0.01, in relation to an angle of one degree.
H91	percent per ten thousand A unit of proportion, equal to 0.01, in relation to multiples of ten thousand.
H92	percent per one hundred thousand A unit of proportion, equal to 0.01, in relation to multiples of one hundred thousand.
H93	percent per hundred A unit of proportion, equal to 0.01, in relation to multiples of one hundred.
H94	percent per thousand A unit of proportion, equal to 0.01, in relation to multiples of one thousand.
H95	percent per volt A unit of proportion, equal to 0.01, in relation to the SI derived unit volt.
H96	percent per bar A unit of proportion, equal to 0.01, in relation to an atmospheric pressure of one bar.
H98	percent per inch A unit of proportion, equal to 0.01, in relation to an inch.
H99	percent per metre A unit of proportion, equal to 0.01, in relation to a metre.
HA	hank A unit of length, typically for yarn.
HAD	Piece Day Unit for measuring the item amount and time as required by DIN 18451

Used Codes

HAR	hectare Synonym: square hectometre
HBA	hectobar
HBX	hundred boxes A unit of count defining the number of boxes in multiples of one hundred box units.
HC	hundred count A unit of count defining the number of units counted in multiples of 100.
HDW	hundred kilogram, dry weight A unit of mass defining the number of hundred kilograms of a product, disregarding the water content of the product.
HEA	head A unit of count defining the number of heads (head: a person or animal considered as one of a number).
HGM	hectogram
HH	hundred cubic foot A unit of volume equal to one hundred cubic foot.
HIU	hundred international unit A unit of count defining the number of international units in multiples of 100.
HJ	metric horse power
HKM	hundred kilogram, net mass A unit of mass defining the number of hundred kilograms of a product, after deductions.
HLT	hectolitre
HM	mile per hour (statute mile)
HMO	Piece Month Unit for measuring the item amount and time as required by DIN 18451
HMQ	million cubic metre A unit of volume equal to one million cubic metres.
HMT	hectometre
HN	conventional millimetre of mercury
HP	conventional millimetre of water
HPA	hectolitre of pure alcohol A unit of volume equal to one hundred litres of pure alcohol.
HTZ	hertz
HUR	hour

Used Codes

HWE	Piece Week Unit for measuring the item amount and time as required by DIN 18451
IA	inch pound (pound inch)
IE	person A unit of count defining the number of persons.
INH	inch
INK	square inch
INQ	cubic inch Synonym: inch cubed
ISD	international sugar degree A unit of measure defining the sugar content of a solution, expressed in degrees.
IU	inch per second
IV	inch per second squared
J10	percent per millimetre A unit of proportion, equal to 0.01, in relation to a millimetre.
J12	per mille per psi A unit of pressure equal to one thousandth of a psi (pound-force per square inch).
J13	degree API A unit of relative density as a measure of how heavy or light a petroleum liquid is compared to water (API: American Petroleum Institute).
J14	degree Baume (origin scale) A traditional unit of relative density for liquids. Named after Antoine Baumé.
J15	degree Baume (US heavy) A unit of relative density for liquids heavier than water.
J16	degree Baume (US light) A unit of relative density for liquids lighter than water.
J17	degree Balling A unit of density as a measure of sugar content, especially of beer wort. Named after Karl Balling.
J18	degree Brix A unit of proportion used in measuring the dissolved sugar-to-water mass ratio of a liquid. Named after Adolf Brix.
J19	degree Fahrenheit hour square foot per British thermal unit (thermochemical)
J2	joule per kilogram
J20	degree Fahrenheit per kelvin

Used Codes

J21	degree Fahrenheit per bar
J22	degree Fahrenheit hour square foot per British thermal unit (international table)
J23	degree Fahrenheit per hour
J24	degree Fahrenheit per minute
J25	degree Fahrenheit per second
J26	reciprocal degree Fahrenheit
J27	degree Oechsle A unit of density as a measure of sugar content of must, the unfermented liqueur from which wine is made. Named after Ferdinand Oechsle.
J28	degree Rankine per hour
J29	degree Rankine per minute
J30	degree Rankine per second
J31	degree Twaddell A unit of density for liquids that are heavier than water. 1 degree Twaddle represents a difference in specific gravity of 0.005.
J32	micropoise
J33	microgram per kilogram
J34	microgram per cubic metre kelvin
J35	microgram per cubic metre bar
J36	microlitre per litre
J38	baud A unit of signal transmission speed equal to one signalling event per second.
J39	British thermal unit (mean)
J40	British thermal unit (international table) foot per hour square foot degree Fahrenheit
J41	British thermal unit (international table) inch per hour square foot degree Fahrenheit
J42	British thermal unit (international table) inch per second square foot degree Fahrenheit
J43	British thermal unit (international table) per pound degree Fahrenheit
J44	British thermal unit (international table) per minute
J45	British thermal unit (international table) per second
J46	British thermal unit (thermochemical) foot per hour square foot degree Fahrenheit
J47	British thermal unit (thermochemical) per hour

Used Codes

J48	British thermal unit (thermochemical) inch per hour square foot degree Fahrenheit
J49	British thermal unit (thermochemical) inch per second square foot degree Fahrenheit
J50	British thermal unit (thermochemical) per pound degree Fahrenheit
J51	British thermal unit (thermochemical) per minute
J52	British thermal unit (thermochemical) per second
J53	coulomb square metre per kilogram
J54	megabaud A unit of signal transmission speed equal to 10 to the power of 6 (1000000) signaling events per second.
J55	watt second
J56	bar per bar
J57	barrel (UK petroleum)
J58	barrel (UK petroleum) per minute
J59	barrel (UK petroleum) per day
J60	barrel (UK petroleum) per hour
J61	barrel (UK petroleum) per second
J62	barrel (US petroleum) per hour
J63	barrel (US petroleum) per second
J64	bushel (UK) per day
J65	bushel (UK) per hour
J66	bushel (UK) per minute
J67	bushel (UK) per second
J68	bushel (US dry) per day
J69	bushel (US dry) per hour
J70	bushel (US dry) per minute
J71	bushel (US dry) per second
J72	centinewton metre
J73	centipoise per kelvin
J74	centipoise per bar
J75	calorie (mean)
J76	calorie (international table) per gram degree Celsius
J78	calorie (thermochemical) per centimetre second degree Celsius
J79	calorie (thermochemical) per gram degree Celsius

Used Codes

J81	calorie (thermochemical) per minute
J82	calorie (thermochemical) per second
J83	clo
J84	centimetre per second kelvin
J85	centimetre per second bar
J87	cubic centimetre per cubic metre
J89	centimetre of mercury
J90	cubic decimetre per day
J91	cubic decimetre per cubic metre
J92	cubic decimetre per minute
J93	cubic decimetre per second
J94	dyne centimetre
J95	ounce (UK fluid) per day
J96	ounce (UK fluid) per hour
J97	ounce (UK fluid) per minute
J98	ounce (UK fluid) per second
J99	ounce (US fluid) per day
JE	joule per kelvin
JK	megajoule per kilogram
JM	megajoule per cubic metre
JNT	pipeline joint A count of the number of pipeline joints.
JOU	joule
JPS	hundred metre A unit of count defining the number of 100 metre lengths.
JWL	number of jewels A unit of count defining the number of jewels (jewel: precious stone).
K1	kilowatt demand A unit of measure defining the power load measured at predetermined intervals.
K10	ounce (US fluid) per hour
K11	ounce (US fluid) per minute
K12	ounce (US fluid) per second
K13	foot per degree Fahrenheit

Used Codes

K14	foot per hour
K15	foot pound-force per hour
K16	foot pound-force per minute
K17	foot per psi
K18	foot per second degree Fahrenheit
K19	foot per second psi
K2	kilovolt ampere reactive demand A unit of measure defining the reactive power demand equal to one kilovolt ampere of reactive power.
K20	reciprocal cubic foot
K21	cubic foot per degree Fahrenheit
K22	cubic foot per day
K23	cubic foot per psi
K24	foot of water
K25	foot of mercury
K26	gallon (UK) per day
K27	gallon (UK) per hour
K28	gallon (UK) per second
K3	kilovolt ampere reactive hour A unit of measure defining the accumulated reactive energy equal to one kilovolt ampere of reactive power per hour.
K30	gallon (US liquid) per second
K31	gram-force per square centimetre
K32	gill (UK) per day
K33	gill (UK) per hour
K34	gill (UK) per minute
K35	gill (UK) per second
K36	gill (US) per day
K37	gill (US) per hour
K38	gill (US) per minute
K39	gill (US) per second
K40	standard acceleration of free fall
K41	grain per gallon (US)
K42	horsepower (boiler)

Used Codes

K43	horsepower (electric)
K45	inch per degree Fahrenheit
K46	inch per psi
K47	inch per second degree Fahrenheit
K48	inch per second psi
K49	reciprocal cubic inch
K5	kilovolt ampere (reactive) Use kilovar (common code KVR)
K50	kilobaud A unit of signal transmission speed equal to 10 to the power of 3 (1000) signaling events per second.
K51	kilocalorie (mean)
K52	kilocalorie (international table) per hour metre degree Celsius
K53	kilocalorie (thermochemical)
K54	kilocalorie (thermochemical) per minute
K55	kilocalorie (thermochemical) per second
K58	kilomole per hour
K59	kilomole per cubic metre kelvin
K6	kilolitre
K60	kilomole per cubic metre bar
K61	kilomole per minute
K62	litre per litre
K63	reciprocal litre
K64	pound (avoirdupois) per degree Fahrenheit
K65	pound (avoirdupois) square foot
K66	pound (avoirdupois) per day
K67	pound per foot hour
K68	pound per foot second
K69	pound (avoirdupois) per cubic foot degree Fahrenheit
K70	pound (avoirdupois) per cubic foot psi
K71	pound (avoirdupois) per gallon (UK)
K73	pound (avoirdupois) per hour degree Fahrenheit
K74	pound (avoirdupois) per hour psi
K75	pound (avoirdupois) per cubic inch degree Fahrenheit

Used Codes

K76	pound (avoirdupois) per cubic inch psi
K77	pound (avoirdupois) per psi
K78	pound (avoirdupois) per minute
K79	pound (avoirdupois) per minute degree Fahrenheit
K80	pound (avoirdupois) per minute psi
K81	pound (avoirdupois) per second
K82	pound (avoirdupois) per second degree Fahrenheit
K83	pound (avoirdupois) per second psi
K84	pound per cubic yard
K85	pound-force per square foot
K86	pound-force per square inch degree Fahrenheit
K87	psi cubic inch per second
K88	psi litre per second
K89	psi cubic metre per second
K90	psi cubic yard per second
K91	pound-force second per square foot
K92	pound-force second per square inch
K93	reciprocal psi
K94	quart (UK liquid) per day
K95	quart (UK liquid) per hour
K96	quart (UK liquid) per minute
K97	quart (UK liquid) per second
K98	quart (US liquid) per day
K99	quart (US liquid) per hour
KA	cake A unit of count defining the number of cakes (cake: object shaped into a flat, compact mass).
KAT	katal A unit of catalytic activity defining the catalytic activity of enzymes and other catalysts.
KB	kilocharacter A unit of information equal to 10 to the power of 3 (1000) characters.
KBA	kilobar
KCC	kilogram of choline chloride A unit of mass equal to one thousand grams of choline chloride.

Used Codes

KDW	kilogram drained net weight A unit of mass defining the net number of kilograms of a product, disregarding the liquid content of the product.
KEL	kelvin Refer ISO 80000-5 (Quantities and units — Part 5: Thermodynamics)
KGM	kilogram A unit of mass equal to one thousand grams.
KGS	kilogram per second
KHY	kilogram of hydrogen peroxide A unit of mass equal to one thousand grams of hydrogen peroxide.
KHZ	kilohertz
KI	kilogram per millimetre width
KIC	kilogram, including container A unit of mass defining the number of kilograms of a product, including its container.
KIP	kilogram, including inner packaging A unit of mass defining the number of kilograms of a product, including its inner packaging materials.
KJ	kilosegment A unit of information equal to 10 to the power of 3 (1000) segments.
KJO	kilojoule
KL	kilogram per metre
KLK	lactic dry material percentage A unit of proportion defining the percentage of dry lactic material in a product.
KLX	kilolux A unit of illuminance equal to one thousand lux.
KMA	kilogram of methylamine A unit of mass equal to one thousand grams of methylamine.
KMH	kilometre per hour
KMK	square kilometre
KMQ	kilogram per cubic metre A unit of weight expressed in kilograms of a substance that fills a volume of one cubic metre.
KMT	kilometre
KNI	kilogram of nitrogen A unit of mass equal to one thousand grams of nitrogen.

Used Codes

KNM	kilonewton per square metre Pressure expressed in kN/m ² .
KNS	kilogram named substance A unit of mass equal to one kilogram of a named substance.
KNT	knot
KO	milliequivalence caustic potash per gram of product A unit of count defining the number of milligrams of potassium hydroxide per gram of product as a measure of the concentration of potassium hydroxide in the product.
KPA	kilopascal
KPH	kilogram of potassium hydroxide (caustic potash) A unit of mass equal to one thousand grams of potassium hydroxide (caustic potash).
KPO	kilogram of potassium oxide A unit of mass equal to one thousand grams of potassium oxide.
KPP	kilogram of phosphorus pentoxide (phosphoric anhydride) A unit of mass equal to one thousand grams of phosphorus pentoxide phosphoric anhydride.
KR	kiloroentgen
KSD	kilogram of substance 90 % dry A unit of mass equal to one thousand grams of a named substance that is 90% dry.
KSH	kilogram of sodium hydroxide (caustic soda) A unit of mass equal to one thousand grams of sodium hydroxide (caustic soda).
KT	kit A unit of count defining the number of kits (kit: tub, barrel or pail).
KTN	kilotonne
KUR	kilogram of uranium A unit of mass equal to one thousand grams of uranium.
KVA	kilovolt - ampere
KVR	kilovar
KVT	kilovolt
KW	kilogram per millimetre
KWH	kilowatt hour
KWN	Kilowatt hour per normalized cubic metre Kilowatt hour per normalized cubic metre (temperature 0°C and pressure 1013.25 millibars).

Used Codes

KWO	kilogram of tungsten trioxide A unit of mass equal to one thousand grams of tungsten trioxide.
KWS	Kilowatt hour per standard cubic metre Kilowatt hour per standard cubic metre (temperature 15°C and pressure 1013.25 millibars).
KWT	kilowatt
KWY	kilowatt year killowatt year
KX	millilitre per kilogram
L10	quart (US liquid) per minute
L11	quart (US liquid) per second
L12	metre per second kelvin
L13	metre per second bar
L14	square metre hour degree Celsius per kilocalorie (international table)
L15	millipascal second per kelvin
L16	millipascal second per bar
L17	milligram per cubic metre kelvin
L18	milligram per cubic metre bar
L19	millilitre per litre
L2	litre per minute
L20	reciprocal cubic millimetre
L21	cubic millimetre per cubic metre
L23	mole per hour
L24	mole per kilogram kelvin
L25	mole per kilogram bar
L26	mole per litre kelvin
L27	mole per litre bar
L28	mole per cubic metre kelvin
L29	mole per cubic metre bar
L30	mole per minute
L31	milliroentgen aequivalent men
L32	nanogram per kilogram
L33	ounce (avoirdupois) per day
L34	ounce (avoirdupois) per hour

Used Codes

L35	ounce (avoirdupois) per minute
L36	ounce (avoirdupois) per second
L37	ounce (avoirdupois) per gallon (UK)
L38	ounce (avoirdupois) per gallon (US)
L39	ounce (avoirdupois) per cubic inch
L40	ounce (avoirdupois)-force
L41	ounce (avoirdupois)-force inch
L42	pico Siemens per metre
L43	peck (UK)
L44	peck (UK) per day
L45	peck (UK) per hour
L46	peck (UK) per minute
L47	peck (UK) per second
L48	peck (US dry) per day
L49	peck (US dry) per hour
L50	peck (US dry) per minute
L51	peck (US dry) per second
L52	psi per psi
L53	pint (UK) per day
L54	pint (UK) per hour
L55	pint (UK) per minute
L56	pint (UK) per second
L57	pint (US liquid) per day
L58	pint (US liquid) per hour
L59	pint (US liquid) per minute
L60	pint (US liquid) per second
L63	slug per day
L64	slug per foot second
L65	slug per cubic foot
L66	slug per hour
L67	slug per minute
L68	slug per second
L69	tonne per kelvin

Used Codes

L70	tonne per bar
L71	tonne per day
L72	tonne per day kelvin
L73	tonne per day bar
L74	tonne per hour kelvin
L75	tonne per hour bar
L76	tonne per cubic metre kelvin
L77	tonne per cubic metre bar
L78	tonne per minute
L79	tonne per minute kelvin
L80	tonne per minute bar
L81	tonne per second
L82	tonne per second kelvin
L83	tonne per second bar
L84	ton (UK shipping)
L85	ton long per day
L86	ton (US shipping)
L87	ton short per degree Fahrenheit
L88	ton short per day
L89	ton short per hour degree Fahrenheit
L90	ton short per hour psi
L91	ton short per psi
L92	ton (UK long) per cubic yard
L93	ton (US short) per cubic yard
L94	ton-force (US short)
L95	common year
L96	sidereal year
L98	yard per degree Fahrenheit
L99	yard per psi
LA	pound per cubic inch
LAC	lactose excess percentage A unit of proportion defining the percentage of lactose in a product that exceeds a defined percentage level.
LBR	pound

Used Codes

LBT	troy pound (US)
LD	litre per day
LEF	leaf A unit of count defining the number of leaves.
LF	linear foot A unit of count defining the number of feet (12-inch) in length of a uniform width object.
LH	labour hour A unit of time defining the number of labour hours.
LK	link A unit of distance equal to 0.01 chain.
LM	linear metre A unit of count defining the number of metres in length of a uniform width object.
LN	length A unit of distance defining the linear extent of an item measured from end to end.
LO	lot [unit of procurement] A unit of count defining the number of lots (lot: a collection of associated items).
LP	liquid pound A unit of mass defining the number of pounds of a liquid substance.
LPA	litre of pure alcohol A unit of volume equal to one litre of pure alcohol.
LR	layer A unit of count defining the number of layers.
LS	lump sum A unit of count defining the number of whole or a complete monetary amounts.
LTN	ton (UK) or long ton (US) Synonym: gross ton (2240 lb)
LTR	litre
LUB	metric ton, lubricating oil A unit of mass defining the number of metric tons of lubricating oil.
LUM	lumen
LUX	lux
LY	linear yard A unit of count defining the number of 36-inch units in length of a uniform width object.

Used Codes

M1	milligram per litre
M10	reciprocal cubic yard
M11	cubic yard per degree Fahrenheit
M12	cubic yard per day
M13	cubic yard per hour
M14	cubic yard per psi
M15	cubic yard per minute
M16	cubic yard per second
M17	kilohertz metre
M18	gigahertz metre
M19	Beaufort An empirical measure for describing wind speed based mainly on observed sea conditions. The Beaufort scale indicates the wind speed by numbers that typically range from 0 for calm, to 12 for hurricane.
M20	reciprocal megakelvin or megakelvin to the power minus one
M21	reciprocal kilovolt - ampere reciprocal hour
M22	millilitre per square centimetre minute
M23	newton per centimetre
M24	ohm kilometre
M25	percent per degree Celsius A unit of proportion, equal to 0.01, in relation to a temperature of one degree.
M26	gigaohm per metre
M27	megahertz metre
M29	kilogram per kilogram
M30	reciprocal volt - ampere reciprocal second
M31	kilogram per kilometre
M32	pascal second per litre
M33	millimole per litre
M34	newton metre per square metre
M35	millivolt - ampere
M36	30-day month A unit of count defining the number of months expressed in multiples of 30 days, one day equals 24 hours.

Used Codes

M37	actual/360 A unit of count defining the number of years expressed in multiples of 360 days, one day equals 24 hours.
M38	kilometre per second squared 1000-fold of the SI base unit metre divided by the power of the SI base unit second by exponent 2.
M39	centimetre per second squared 0,01-fold of the SI base unit metre divided by the power of the SI base unit second by exponent 2.
M4	monetary value A unit of measure expressed as a monetary amount.
M40	yard per second squared Unit of the length according to the Anglo-American and Imperial system of units divided by the power of the SI base unit second by exponent 2.
M41	millimetre per second squared 0,001-fold of the SI base unit metre divided by the power of the SI base unit second by exponent 2.
M42	mile (statute mile) per second squared Unit of the length according to the Imperial system of units divided by the power of the SI base unit second by exponent 2.
M43	mil Unit to indicate an angle at military zone, equal to the 6400th part of the full circle of the 360° or 2·p·rad.
M44	revolution Unit to identify an angle of the full circle of 360° or 2·p·rad (Refer ISO/TC12 SI Guide).
M45	degree [unit of angle] per second squared 360 part of a full circle divided by the power of the SI base unit second and the exponent 2.
M46	revolution per minute Unit of the angular velocity.
M47	circular mil Unit of an area, of which the size is given by a diameter of length of 1 mm (0,001 in) based on the formula: $area = p \cdot (diameter/2)^2$.
M48	square mile (based on U.S. survey foot) Unit of the area, which is mainly common in the agriculture and forestry.
M49	chain (based on U.S. survey foot) Unit of the length according the Anglo-American system of units.
M5	microcurie

Used Codes

M50	furlong Unit commonly used in Great Britain at rural distances: 1 furlong = 40 rods = 10 chains (UK) = 1/8 mile = 1/10 furlong = 220 yards = 660 foot.
M51	foot (U.S. survey) Unit commonly used in the United States for ordnance survey.
M52	mile (based on U.S. survey foot) Unit commonly used in the United States for ordnance survey.
M53	metre per pascal SI base unit metre divided by the derived SI unit pascal.
M55	metre per radiant Unit of the translation factor for implementation from rotation to linear movement.
M56	shake Unit for a very short period.
M57	mile per minute Unit of velocity from the Imperial system of units.
M58	mile per second Unit of the velocity from the Imperial system of units.
M59	metre per second pascal SI base unit meter divided by the product of SI base unit second and the derived SI unit pascal.
M60	metre per hour SI base unit metre divided by the unit hour.
M61	inch per year Unit of the length according to the Anglo-American and Imperial system of units divided by the unit common year with 365 days.
M62	kilometre per second 1000-fold of the SI base unit metre divided by the SI base unit second.
M63	inch per minute Unit inch according to the Anglo-American and Imperial system of units divided by the unit minute.
M64	yard per second Unit yard according to the Anglo-American and Imperial system of units divided by the SI base unit second.
M65	yard per minute Unit yard according to the Anglo-American and Imperial system of units divided by the unit minute.

Used Codes

M66	yard per hour Unit yard according to the Anglo-American and Imperial system of units divided by the unit hour.
M67	acre-foot (based on U.S. survey foot) Unit of the volume, which is used in the United States to measure/gauge the capacity of reservoirs.
M68	cord (128 ft ³) Traditional unit of the volume of stacked firewood which has been measured with a cord.
M69	cubic mile (UK statute) Unit of volume according to the Imperial system of units.
M7	micro-inch
M70	ton, register Traditional unit of the cargo capacity.
M71	cubic metre per pascal Power of the SI base unit meter by exponent 3 divided by the derived SI base unit pascal.
M72	bel Logarithmic relationship to base 10.
M73	kilogram per cubic metre pascal SI base unit kilogram divided by the product of the power of the SI base unit metre with exponent 3 and the derived SI unit pascal.
M74	kilogram per pascal SI base unit kilogram divided by the derived SI unit pascal.
M75	kilopound-force 1000-fold of the unit of the force pound-force (lbf) according to the Anglo-American system of units with the relationship.
M76	poundal Non SI-conforming unit of the power, which corresponds to a mass of a pound multiplied with the acceleration of a foot per square second.
M77	kilogram metre per second squared Product of the SI base unit kilogram and the SI base unit metre divided by the power of the SI base unit second by exponent 2.
M78	pond 0,001-fold of the unit of the weight, defined as a mass of 1 kg which finds out about a weight strength from 1 kp by the gravitational force at sea level which corresponds to a strength of 9,806 65 newton.
M79	square foot per hour Power of the unit foot according to the Anglo-American and Imperial system of units by exponent 2 divided by the unit of time hour.

Used Codes

M80	<p>stokes per pascal</p> <p>CGS (Centimetre-Gram-Second system) unit stokes divided by the derived SI unit pascal.</p>
M81	<p>square centimetre per second</p> <p>0,000 1-fold of the power of the SI base unit metre by exponent 2 divided by the SI base unit second.</p>
M82	<p>square metre per second pascal</p> <p>Power of the SI base unit metre with the exponent 2 divided by the SI base unit second and the derived SI unit pascal.</p>
M83	<p>denier</p> <p>Traditional unit for the indication of the linear mass of textile fibers and yarns.</p>
M84	<p>pound per yard</p> <p>Unit for linear mass according to avoirdupois system of units.</p>
M85	<p>ton, assay</p> <p>Non SI-conforming unit of the mass used in the mineralogy to determine the concentration of precious metals in ore according to the mass of the precious metal in milligrams in a sample of the mass of an assay sound (number of troy ounces in a short ton (1 000 lb)).</p>
M86	<p>pfund</p> <p>Outdated unit of the mass used in Germany.</p>
M87	<p>kilogram per second pascal</p> <p>SI base unit kilogram divided by the product of the SI base unit second and the derived SI unit pascal.</p>
M88	<p>tonne per month</p> <p>Unit tonne divided by the unit month.</p>
M89	<p>tonne per year</p> <p>Unit tonne divided by the unit year with 365 days.</p>
M9	<p>million Btu per 1000 cubic foot</p>
M90	<p>kilopound per hour</p> <p>1000-fold of the unit of the mass avoirdupois pound according to the avoirdupois unit system divided by the unit hour.</p>
M91	<p>pound per pound</p> <p>Proportion of the mass consisting of the avoirdupois pound according to the avoirdupois unit system divided by the avoirdupois pound according to the avoirdupois unit system.</p>
M92	<p>pound-force foot</p> <p>Product of the unit pound-force according to the Anglo-American system of units and the unit foot according to the Anglo-American and the Imperial system of units.</p>

Used Codes

M93	newton metre per radian Product of the derived SI unit newton and the SI base unit metre divided by the unit radian.
M94	kilogram metre Unit of imbalance as a product of the SI base unit kilogram and the SI base unit metre.
M95	poundal foot Product of the non SI-conforming unit of the force poundal and the unit foot according to the Anglo-American and Imperial system of units .
M96	poundal inch Product of the non SI-conforming unit of the force poundal and the unit inch according to the Anglo-American and Imperial system of units .
M97	dyne metre CGS (Centimetre-Gram-Second system) unit of the rotational moment.
M98	kilogram centimetre per second Product of the SI base unit kilogram and the 0,01-fold of the SI base unit metre divided by the SI base unit second.
M99	gram centimetre per second Product of the 0,001-fold of the SI base unit kilogram and the 0,01-fold of the SI base unit metre divided by the SI base unit second.
MAH	megavolt ampere reactive hour A unit of electrical reactive power defining the total amount of reactive power across a power system.
MAL	megalitre
MAM	megametre
MAR	megavar A unit of electrical reactive power represented by a current of one thousand amperes flowing due a potential difference of one thousand volts where the sine of the phase angle between them is 1.
MAW	megawatt A unit of power defining the rate of energy transferred or consumed when a current of 1000 amperes flows due to a potential of 1000 volts at unity power factor.
MBE	thousand standard brick equivalent A unit of count defining the number of one thousand brick equivalent units.
MBF	thousand board foot A unit of volume equal to one thousand board foot.
MBR	millibar
MC	microgram
MCU	millicurie

Used Codes

MD	air dry metric ton A unit of count defining the number of metric tons of a product, disregarding the water content of the product.
MGM	milligram
MHZ	megahertz
MIK	square mile (statute mile)
MIL	thousand
MIN	minute [unit of time]
MIO	million
MIU	million international unit A unit of count defining the number of international units in multiples of 10 to the power of 6.
MKD	Square Metre Day Unit for measuring physical dimensions and time as required by DIN 18451
MKM	Square Metre Month Unit for measuring physical dimensions and time as required by DIN 18451
MKW	Square Metre Week Unit for measuring physical dimensions and time as required by DIN 18451
MLD	milliard Synonym: billion (US)
MLT	millilitre
MMK	square millimetre
MMQ	cubic millimetre
MMT	millimetre
MND	kilogram, dry weight A unit of mass defining the number of kilograms of a product, disregarding the water content of the product.
MNJ	Mega Joule per Normalised cubic Metre Energy in Mega Joules per normalised cubic metre for gas (temperature 0°C and pressure 101325 millibars)
MON	month Unit of time equal to 1/12 of a year of 365,25 days.
MPA	megapascal
MQD	Cubic Metre Day Unit for measuring physical dimensions and time as required by DIN 18451
MQH	cubic metre per hour

Used Codes

MQM	Cubic Metre Month Unit for measuring physical dimensions and time as required by DIN 18451
MQS	cubic metre per second
MQW	Cubic Metre Week Unit for measuring physical dimensions and time as required by DIN 18451
MRD	Metre Day Unit for measuring physical dimensions and time as required by DIN 18451
MRM	Metre Month Unit for measuring physical dimensions and time as required by DIN 18451
MRW	Metre Week Unit for measuring physical dimensions and time, as required by DIN 18451
MSK	metre per second squared
MTK	square metre
MTQ	cubic metre Synonym: metre cubed
MTR	metre
MTS	metre per second
MTZ	milihertz A unit of frequency equal to 0.001 cycle per second
MVA	megavolt - ampere
MWH	megawatt hour (1000 kW.h) A unit of power defining the total amount of bulk energy transferred or consumed.
N1	pen calorie A unit of count defining the number of calories prescribed daily for parenteral/enteral therapy.
N10	pound foot per second Product of the avoirdupois pound according to the avoirdupois unit system and the unit foot according to the Anglo-American and Imperial system of units divided by the SI base unit second.
N11	pound inch per second Product of the avoirdupois pound according to the avoirdupois unit system and the unit inch according to the Anglo-American and Imperial system of units divided by the SI base unit second.
N12	Pferdestaerke Obsolete unit of the power relating to DIN 1301-3:1979: 1 PS = 735,498 75 W.

Used Codes

N13	centimetre of mercury (0 °C) Non SI-conforming unit of pressure, at which a value of 1 cmHg meets the static pressure, which is generated by a mercury at a temperature of 0 °C with a height of 1 centimetre .
N14	centimetre of water (4 °C) Non SI-conforming unit of pressure, at which a value of 1 cmH ₂ O meets the static pressure, which is generated by a head of water at a temperature of 4 °C with a height of 1 centimetre .
N15	foot of water (39.2 °F) Non SI-conforming unit of pressure according to the Anglo-American and Imperial system for units, whereas the value of 1 ftH ₂ O is equivalent to the static pressure, which is generated by a head of water at a temperature 39,2°F with a height of 1 foot .
N16	inch of mercury (32 °F) Non SI-conforming unit of pressure according to the Anglo-American and Imperial system for units, whereas the value of 1 inHg meets the static pressure, which is generated by a mercury at a temperature of 32°F with a height of 1 inch.
N17	inch of mercury (60 °F) Non SI-conforming unit of pressure according to the Anglo-American and Imperial system for units, whereas the value of 1 inHg meets the static pressure, which is generated by a mercury at a temperature of 60°F with a height of 1 inch.
N18	inch of water (39.2 °F) Non SI-conforming unit of pressure according to the Anglo-American and Imperial system for units, whereas the value of 1 inH ₂ O meets the static pressure, which is generated by a head of water at a temperature of 39,2°F with a height of 1 inch .
N19	inch of water (60 °F) Non SI-conforming unit of pressure according to the Anglo-American and Imperial system for units, whereas the value of 1 inH ₂ O meets the static pressure, which is generated by a head of water at a temperature of 60°F with a height of 1 inch .
N20	kip per square inch Non SI-conforming unit of the pressure according to the Anglo-American system of units as the 1000-fold of the unit of the force pound-force divided by the power of the unit inch by exponent 2.
N21	poundal per square foot Non SI-conforming unit of pressure by the Imperial system of units according to NIST: 1 pdl/ft ² = 1,488 164 Pa.
N22	ounce (avoirdupois) per square inch Unit of the surface specific mass (avoirdupois ounce according to the avoirdupois system of units according to the surface square inch according to the Anglo-American and Imperial system of units).

Used Codes

N23	conventional metre of water Not SI-conforming unit of pressure, whereas a value of 1 mH ₂ O is equivalent to the static pressure, which is produced by one metre high water column .
N24	gram per square millimetre 0,001-fold of the SI base unit kilogram divided by the 0.000 001-fold of the power of the SI base unit meter by exponent 2.
N25	pound per square yard Unit for areal-related mass as a unit pound according to the avoirdupois unit system divided by the power of the unit yard according to the Anglo-American and Imperial system of units with exponent 2.
N26	poundal per square inch Non SI-conforming unit of the pressure according to the Imperial system of units (poundal by square inch).
N27	foot to the fourth power Power of the unit foot according to the Anglo-American and Imperial system of units by exponent 4 according to NIST: 1 ft ⁴ = 8,630 975 m ⁴ .
N28	cubic decimetre per kilogram 0,001 fold of the power of the SI base unit meter by exponent 3 divided by the SI based unit kilogram.
N29	cubic foot per pound Power of the unit foot according to the Anglo-American and Imperial system of units by exponent 3 divided by the unit avoirdupois pound according to the avoirdupois unit system.
N3	print point
N30	cubic inch per pound Power of the unit inch according to the Anglo-American and Imperial system of units by exponent 3 divided by the avoirdupois pound according to the avoirdupois unit system .
N31	kilonewton per metre 1000-fold of the derived SI unit newton divided by the SI base unit metre.
N32	poundal per inch Non SI-conforming unit of the surface tension according to the Imperial unit system as quotient poundal by inch.
N33	pound-force per yard Unit of force per unit length based on the Anglo-American system of units.
N34	poundal second per square foot Non SI-conforming unit of viscosity.
N35	poise per pascal CGS (Centimetre-Gram-Second system) unit poise divided by the derived SI unit pascal.

Used Codes

N36	newton second per square metre Unit of the dynamic viscosity as a product of unit of the pressure (newton by square metre) multiplied with the SI base unit second.
N37	kilogram per metre second Unit of the dynamic viscosity as a quotient SI base unit kilogram divided by the SI base unit metre and by the SI base unit second.
N38	kilogram per metre minute Unit of the dynamic viscosity as a quotient SI base unit kilogram divided by the SI base unit metre and by the unit minute.
N39	kilogram per metre day Unit of the dynamic viscosity as a quotient SI base unit kilogram divided by the SI base unit metre and by the unit day.
N40	kilogram per metre hour Unit of the dynamic viscosity as a quotient SI base unit kilogram divided by the SI base unit metre and by the unit hour.
N41	gram per centimetre second Unit of the dynamic viscosity as a quotient of the 0,001-fold of the SI base unit kilogram divided by the 0,01-fold of the SI base unit metre and SI base unit second.
N42	poundal second per square inch Non SI-conforming unit of dynamic viscosity according to the Imperial system of units as product unit of the pressure (poundal by square inch) multiplied by the SI base unit second.
N43	pound per foot minute Unit of the dynamic viscosity according to the Anglo-American unit system.
N44	pound per foot day Unit of the dynamic viscosity according to the Anglo-American unit system.
N45	cubic metre per second pascal Power of the SI base unit meter by exponent 3 divided by the product of the SI base unit second and the derived SI base unit pascal.
N46	foot poundal Unit of the work (force-path).
N47	inch poundal Unit of work (force multiplied by path) according to the Imperial system of units as a product unit inch multiplied by poundal.
N48	watt per square centimetre Derived SI unit watt divided by the power of the 0,01-fold the SI base unit metre by exponent 2.
N49	watt per square inch Derived SI unit watt divided by the power of the unit inch according to the Anglo-American and Imperial system of units by exponent 2.

Used Codes

N50	British thermal unit (international table) per square foot hour Unit of the surface heat flux according to the Imperial system of units.
N51	British thermal unit (thermochemical) per square foot hour Unit of the surface heat flux according to the Imperial system of units.
N52	British thermal unit (thermochemical) per square foot minute Unit of the surface heat flux according to the Imperial system of units.
N53	British thermal unit (international table) per square foot second Unit of the surface heat flux according to the Imperial system of units.
N54	British thermal unit (thermochemical) per square foot second Unit of the surface heat flux according to the Imperial system of units.
N55	British thermal unit (international table) per square inch second Unit of the surface heat flux according to the Imperial system of units.
N56	calorie (thermochemical) per square centimetre minute Unit of the surface heat flux according to the Imperial system of units.
N57	calorie (thermochemical) per square centimetre second Unit of the surface heat flux according to the Imperial system of units.
N58	British thermal unit (international table) per cubic foot Unit of the energy density according to the Imperial system of units.
N59	British thermal unit (thermochemical) per cubic foot Unit of the energy density according to the Imperial system of units.
N60	British thermal unit (international table) per degree Fahrenheit Unit of the heat capacity according to the Imperial system of units.
N61	British thermal unit (thermochemical) per degree Fahrenheit Unit of the heat capacity according to the Imperial system of units.
N62	British thermal unit (international table) per degree Rankine Unit of the heat capacity according to the Imperial system of units.
N63	British thermal unit (thermochemical) per degree Rankine Unit of the heat capacity according to the Imperial system of units.
N64	British thermal unit (thermochemical) per pound degree Rankine Unit of the heat capacity (British thermal unit according to the international table according to the Rankine degree) according to the Imperial system of units divided by the unit avoirdupois pound according to the avoirdupois system of units.
N65	kilocalorie (international table) per gram kelvin Unit of the mass-related heat capacity as quotient 1000-fold of the calorie (international table) divided by the product of the 0,001-fold of the SI base units kilogram and kelvin.

Used Codes

N66	British thermal unit (39 °F) Unit of heat energy according to the Imperial system of units in a reference temperature of 39 °F.
N67	British thermal unit (59 °F) Unit of heat energy according to the Imperial system of units in a reference temperature of 59 °F.
N68	British thermal unit (60 °F) Unit of head energy according to the Imperial system of units at a reference temperature of 60 °F.
N69	calorie (20 °C) Unit for quantity of heat, which is to be required for 1 g air free water at a constant pressure from 101,325 kPa, to warm up the pressure of standard atmosphere at sea level, from 19,5 °C on 20,5 °C.
N70	quad (1015 BtuIT) Unit of heat energy according to the imperial system of units.
N71	therm (EC) Unit of heat energy in commercial use, within the EU defined: 1 thm (EC) = 100 000 BtuIT.
N72	therm (U.S.) Unit of heat energy in commercial use.
N73	British thermal unit (thermochemical) per pound Unit of the heat energy according to the Imperial system of units divided the unit avoirdupois pound according to the avoirdupois system of units.
N74	British thermal unit (international table) per hour square foot degree Fahrenheit Unit of the heat transition coefficient according to the Imperial system of units.
N75	British thermal unit (thermochemical) per hour square foot degree Fahrenheit Unit of the heat transition coefficient according to the imperial system of units.
N76	British thermal unit (international table) per second square foot degree Fahrenheit Unit of the heat transition coefficient according to the imperial system of units.
N77	British thermal unit (thermochemical) per second square foot degree Fahrenheit Unit of the heat transition coefficient according to the imperial system of units.
N78	kilowatt per square metre kelvin 1000-fold of the derived SI unit watt divided by the product of the power of the SI base unit metre by exponent 2 and the SI base unit kelvin.
N79	kelvin per pascal SI base unit kelvin divided by the derived SI unit pascal.

Used Codes

N80	watt per metre degree Celsius Derived SI unit watt divided by the product of the SI base unit metre and the unit for temperature degree Celsius.
N81	kilowatt per metre kelvin 1000-fold of the derived SI unit watt divided by the product of the SI base unit metre and the SI base unit kelvin.
N82	kilowatt per metre degree Celsius 1000-fold of the derived SI unit watt divided by the product of the SI base unit metre and the unit for temperature degree Celsius.
N83	metre per degree Celsius metre SI base unit metre divided by the product of the unit degree Celsius and the SI base unit metre.
N84	degree Fahrenheit hour per British thermal unit (international table) Non SI-conforming unit of the thermal resistance according to the Imperial system of units.
N85	degree Fahrenheit hour per British thermal unit (thermochemical) Non SI-conforming unit of the thermal resistance according to the Imperial system of units.
N86	degree Fahrenheit second per British thermal unit (international table) Non SI-conforming unit of the thermal resistance according to the Imperial system of units.
N87	degree Fahrenheit second per British thermal unit (thermochemical) Non SI-conforming unit of the thermal resistance according to the Imperial system of units.
N88	degree Fahrenheit hour square foot per British thermal unit (international table) inch Unit of specific thermal resistance according to the Imperial system of units.
N89	degree Fahrenheit hour square foot per British thermal unit (thermochemical) inch Unit of specific thermal resistance according to the Imperial system of units.
N90	kilofarad 1000-fold of the derived SI unit farad.
N91	reciprocal joule Reciprocal of the derived SI unit joule.
N92	picosiemens 0,000 000 000 001-fold of the derived SI unit siemens.
N93	ampere per pascal SI base unit ampere divided by the derived SI unit pascal.

Used Codes

N94	franklin CGS (Centimetre-Gram-Second system) unit of the electrical charge, where the charge amounts to exactly 1 Fr where the force of 1 dyn on an equal load is performed at a distance of 1 cm.
N95	ampere minute A unit of electric charge defining the amount of charge accumulated by a steady flow of one ampere for one minute..
N96	biot CGS (Centimetre-Gram-Second system) unit of the electric power which is defined by a force of 2 dyn per cm between two parallel conductors of infinite length with negligible cross-section in the distance of 1 cm.
N97	gilbert CGS (Centimetre-Gram-Second system) unit of the magnetomotive force, which is defined by the work to increase the magnetic potential of a positive common pol with 1 erg.
N98	volt per pascal Derived SI unit volt divided by the derived SI unit pascal.
N99	picovolt 0,000 000 000 001-fold of the derived SI unit volt.
NA	milligram per kilogram
NAR	number of articles A unit of count defining the number of articles (article: item).
NCL	number of cells A unit of count defining the number of cells (cell: an enclosed or circumscribed space, cavity, or volume).
NEW	newton
NF	message A unit of count defining the number of messages.
NIL	nil A unit of count defining the number of instances of nothing.
NIU	number of international units A unit of count defining the number of international units.
NL	load A unit of volume defining the number of loads (load: a quantity of items carried or processed at one time).
NM3	Normalised cubic metre Normalised cubic metre (temperature 0°C and pressure 1013.25 millibars)
NMI	nautical mile

Used Codes

NMP	number of packs A unit of count defining the number of packs (pack: a collection of objects packaged together).
NPR	number of pairs A unit of count defining the number of pairs (pair: item described by two's).
NPT	number of parts A unit of count defining the number of parts (part: component of a larger entity).
NQ	mho
NR	micromho
NT	net ton A unit of mass equal to 2000 pounds, see ton (US). Refer International Convention on tonnage measurement of Ships.
NTT	net register ton A unit of mass equal to the total cubic footage after deductions, where 1 register ton is equal to 100 cubic feet. Refer International Convention on tonnage measurement of Ships.
NTU	Nephelometric turbidity unit Nephelometric turbidity unit (NTU) is used for water turbidity level evaluation
NU	newton metre
NX	part per thousand A unit of proportion equal to 10 to the power of -3. Synonym: per mille
OA	panel A unit of count defining the number of panels (panel: a distinct, usually rectangular, section of a surface).
ODE	ozone depletion equivalent A unit of mass defining the ozone depletion potential in kilograms of a product relative to the calculated depletion for the reference substance, Trichlorofluoromethane (CFC-11).
ODG	ODS Grams A unit of measure calculated by multiplying the mass of the substance in grams and the ozone-depleting potential for the substance.
ODK	ODS Kilograms A unit of measure calculated by multiplying the mass of the substance in kilograms and the ozone-depleting potential for the substance.
ODM	ODS Milligrams A unit of measure calculated by multiplying the mass of the substance in milligrams and the ozone-depleting potential for the substance.
OHM	ohm

Used Codes

ON	ounce per square yard
ONZ	ounce (avoirdupois)
OPM	oscillations per minute The number of oscillations per minute.
OT	overtime hour A unit of time defining the number of overtime hours.
OZ	ounce av A unit of measure equal to 1/16 of a pound or about 28.3495 grams (av = avoirdupois). Use ounce (common code ONZ).
OZA	fluid ounce (US)
OZI	fluid ounce (UK)
P1	percent A unit of proportion equal to 0.01.
P10	coulomb per metre Derived SI unit coulomb divided by the SI base unit metre.
P11	kiloweber 1000 fold of the derived SI unit weber.
P12	gamma Unit of magnetic flow density.
P13	kilotesla 1000-fold of the derived SI unit tesla.
P14	joule per second Quotient of the derived SI unit joule divided by the SI base unit second.
P15	joule per minute Quotient from the derived SI unit joule divided by the unit minute.
P16	joule per hour Quotient from the derived SI unit joule divided by the unit hour.
P17	joule per day Quotient from the derived SI unit joule divided by the unit day.
P18	kilojoule per second Quotient from the 1000-fold of the derived SI unit joule divided by the SI base unit second.
P19	kilojoule per minute Quotient from the 1000-fold of the derived SI unit joule divided by the unit minute.
P2	pound per foot

Used Codes

P20	kilojoule per hour Quotient from the 1000-fold of the derived SI unit joule divided by the unit hour.
P21	kilojoule per day Quotient from the 1000-fold of the derived SI unit joule divided by the unit day.
P22	nanoohm 0,000 000 001-fold of the derived SI unit ohm.
P23	ohm circular-mil per foot Unit of resistivity.
P24	kilohenry 1000-fold of the derived SI unit henry.
P25	lumen per square foot Derived SI unit lumen divided by the power of the unit foot according to the Anglo-American and Imperial system of units by exponent 2.
P26	phot CGS (Centimetre-Gram-Second system) unit of luminance, defined as lumen by square centimetre.
P27	footcandle Non SI conform traditional unit, defined as density of light which impinges on a surface which has a distance of one foot from a light source, which shines with an intensity of an international candle.
P28	candela per square inch SI base unit candela divided by the power of unit inch according to the Anglo-American and Imperial system of units by exponent 2.
P29	footlambert Unit of the luminance according to the Anglo-American system of units, defined as emitted or reflected luminance of a lm/ft^2 .
P30	lambert CGS (Centimetre-Gram-Second system) unit of luminance, defined as the emitted or reflected luminance by one lumen per square centimetre.
P31	stilb CGS (Centimetre-Gram-Second system) unit of luminance, defined as emitted or reflected luminance by one lumen per square centimetre.
P32	candela per square foot Base unit SI candela divided by the power of the unit foot according to the Anglo-American and Imperial system of units by exponent 2.
P33	kilocandela 1000-fold of the SI base unit candela.

Used Codes

P34	millicandela 0,001-fold of the SI base unit candela.
P35	Hefner-Kerze Obsolete, non-legal unit of the power in Germany relating to DIN 1301-3: 1979: 1 HK = 0,903 cd.
P36	international candle Obsolete, non-legal unit of the power in Germany relating to DIN 1301-3: 1979: 1 HK = 1,019 cd.
P37	British thermal unit (international table) per square foot Unit of the areal-related energy transmission according to the Imperial system of units.
P38	British thermal unit (thermochemical) per square foot Unit of the areal-related energy transmission according to the Imperial system of units.
P39	calorie (thermochemical) per square centimetre Unit of the areal-related energy transmission according to the Imperial system of units.
P40	langley CGS (Centimetre-Gram-Second system) unit of the areal-related energy transmission (as a measure of the incident quantity of heat of solar radiation on the earth's surface).
P41	decade (logarithmic) $1 \text{ Dec} := \log_2 10 \sim 3,32$ according to the logarithm for frequency range between f_1 and f_2 , when $f_2/f_1 = 10$.
P42	pascal squared second Unit of the set as a product of the power of derived SI unit pascal with exponent 2 and the SI base unit second.
P43	bel per metre Unit bel divided by the SI base unit metre.
P44	pound mole Non SI-conforming unit of quantity of a substance relating that one pound mole of a chemical composition corresponds to the same number of pounds as the molecular weight of one molecule of this composition in atomic mass units.
P45	pound mole per second Non SI-conforming unit of the power of the amount of substance non-SI compliant unit of the molar flux relating that a pound mole of a chemical composition the same number of pound corresponds like the molecular weight of a molecule of this composition in atomic mass units.

Used Codes

P46	pound mole per minute Non SI-conforming unit of the power of the amount of substance non-SI compliant unit of the molar flux relating that a pound mole of a chemical composition the same number of pound corresponds like the molecular weight of a molecule of this composition in atomic mass units.
P47	kilomole per kilogram 1000-fold of the SI base unit mol divided by the SI base unit kilogram.
P48	pound mole per pound Non SI-conforming unit of the material molar flux divided by the avoirdupois pound for mass according to the avoirdupois unit system.
P49	newton square metre per ampere Product of the derived SI unit newton and the power of SI base unit metre with exponent 2 divided by the SI base unit ampere.
P5	five pack A unit of count defining the number of five-packs (five-pack: set of five items packaged together).
P50	weber metre Product of the derived SI unit weber and SI base unit metre.
P51	mol per kilogram pascal SI base unit mol divided by the product of the SI base unit kilogram and the derived SI unit pascal.
P52	mol per cubic metre pascal SI base unit mol divided by the product of the power from the SI base unit metre with exponent 3 and the derived SI unit pascal.
P53	unit pole CGS (Centimetre-Gram-Second system) unit for magnetic flux of a magnetic pole (according to the interaction of identical poles of 1 dyn at a distance of a cm).
P54	milligray per second 0,001-fold of the derived SI unit gray divided by the SI base unit second.
P55	microgray per second 0,000 001-fold of the derived SI unit gray divided by the SI base unit second.
P56	nanogray per second 0,000 000 001-fold of the derived SI unit gray divided by the SI base unit second.
P57	gray per minute SI derived unit gray divided by the unit minute.
P58	milligray per minute 0,001-fold of the derived SI unit gray divided by the unit minute.

Used Codes

P59	microgray per minute 0,000 001-fold of the derived SI unit gray divided by the unit minute.
P60	nanogray per minute 0,000 000 001-fold of the derived SI unit gray divided by the unit minute.
P61	gray per hour SI derived unit gray divided by the unit hour.
P62	milligram per hour 0,001-fold of the derived SI unit gray divided by the unit hour.
P63	microgray per hour 0,000 001-fold of the derived SI unit gray divided by the unit hour.
P64	nanogray per hour 0,000 000 001-fold of the derived SI unit gray divided by the unit hour.
P65	sievert per second Derived SI unit sievert divided by the SI base unit second.
P66	millisievert per second 0,001-fold of the derived SI unit sievert divided by the SI base unit second.
P67	microsievert per second 0,000 001-fold of the derived SI unit sievert divided by the SI base unit second.
P68	nanosievert per second 0,000 000 001-fold of the derived SI unit sievert divided by the SI base unit second.
P69	rem per second Unit for the equivalent tin rate relating to DIN 1301-3:1979: $1 \text{ rem/s} = 0,01 \text{ J}/(\text{kg}\cdot\text{s}) = 1 \text{ Sv/s}$.
P70	sievert per hour Derived SI unit sievert divided by the unit hour.
P71	millisievert per hour 0,001-fold of the derived SI unit sievert divided by the unit hour.
P72	microsievert per hour 0,000 001-fold of the derived SI unit sievert divided by the unit hour.
P73	nanosievert per hour 0,000 000 001-fold of the derived SI unit sievert divided by the unit hour.
P74	sievert per minute Derived SI unit sievert divided by the unit minute.
P75	millisievert per minute 0,001-fold of the derived SI unit sievert divided by the unit minute.

Used Codes

P76	microsievert per minute 0,000 001-fold of the derived SI unit sievert divided by the unit minute.
P77	nanosievert per minute 0,000 000 001-fold of the derived SI unit sievert divided by the unit minute.
P78	reciprocal square inch Complement of the power of the unit inch according to the Anglo-American and Imperial system of units by exponent 2.
P79	pascal square metre per kilogram Unit of the burst index as derived unit for pressure pascal related to the substance, represented as a quotient from the SI base unit kilogram divided by the power of the SI base unit metre by exponent 2.
P80	millipascal per metre 0,001-fold of the derived SI unit pascal divided by the SI base unit metre.
P81	kilopascal per metre 1000-fold of the derived SI unit pascal divided by the SI base unit metre.
P82	hectopascal per metre 100-fold of the derived SI unit pascal divided by the SI base unit metre.
P83	standard atmosphere per metre Outdated unit of the pressure divided by the SI base unit metre.
P84	technical atmosphere per metre Obsolete and non-legal unit of the pressure which is generated by a 10 metre water column divided by the SI base unit metre.
P85	torr per metre CGS (Centimetre-Gram-Second system) unit of the pressure divided by the SI base unit metre.
P86	psi per inch Compound unit for pressure (pound-force according to the Anglo-American unit system divided by the power of the unit inch according to the Anglo-American and Imperial system of units with the exponent 2) divided by the unit inch according to the Anglo-American and Imperial system of units .
P87	cubic metre per second square metre Unit of volume flow cubic meters by second related to the transmission surface in square metres.
P88	rhe Non SI-conforming unit of fluidity of dynamic viscosity.
P89	pound-force foot per inch Unit for length-related rotational moment according to the Anglo-American and Imperial system of units.

Used Codes

P90	pound-force inch per inch Unit for length-related rotational moment according to the Anglo-American and Imperial system of units.
P91	perm (0 °C) Traditional unit for the ability of a material to allow the transition of the steam, defined at a temperature of 0 °C as steam transmittance, where the mass of one grain steam penetrates an area of one foot squared at a pressure from one inch mercury per hour.
P92	perm (23 °C) Traditional unit for the ability of a material to allow the transition of the steam, defined at a temperature of 23 °C as steam transmittance at which the mass of one grain of steam penetrates an area of one square foot at a pressure of one inch mercury per hour.
P93	byte per second Unit byte divided by the SI base unit second.
P94	kilobyte per second 1000-fold of the unit byte divided by the SI base unit second.
P95	megabyte per second 1 000 000-fold of the unit byte divided by the SI base unit second.
P96	reciprocal volt Reciprocal of the derived SI unit volt.
P97	reciprocal radian Reciprocal of the unit radian.
P98	pascal to the power sum of stoichiometric numbers Unit of the equilibrium constant on the basis of the pressure(ISO 80000-9: 2009, 9-35.a).
P99	mole per cubiv metre to the power sum of stoichiometric numbers Unit of the equilibrium constant on the basis of the concentration (ISO 80000-9:2009, 9-36.a).
PAL	pascal
PD	pad A unit of count defining the number of pads (pad: block of paper sheets fastened together at one end).
PFL	proof litre A unit of volume equal to one litre of proof spirits, or the alcohol equivalent thereof. Used for measuring the strength of distilled alcoholic liquors, expressed as a percentage of the alcohol content of a standard mixture at a specific temperature.

Used Codes

PGL	proof gallon A unit of volume equal to one gallon of proof spirits, or the alcohol equivalent thereof. Used for measuring the strength of distilled alcoholic liquors, expressed as a percentage of the alcohol content of a standard mixture at a specific temperature.
PI	pitch A unit of count defining the number of characters that fit in a horizontal inch.
PLA	degree Plato A unit of proportion defining the sugar content of a product, especially in relation to beer.
PO	pound per inch of length
PQ	page per inch A unit of quantity defining the degree of thickness of a bound publication, expressed as the number of pages per inch of thickness.
PR	pair A unit of count defining the number of pairs (pair: item described by two's).
PS	pound-force per square inch
PT	pint (US) Use liquid pint (common code PTL)
PTD	dry pint (US)
PTI	pint (UK)
PTL	liquid pint (US)
PTN	portion A quantity of allowance of food allotted to, or enough for, one person.
Q10	joule per tesla Unit of the magnetic dipole moment of the molecule as derived SI unit joule divided by the derived SI unit tesla.
Q11	erlang Unit of the market value according to the feature of a single feature as a statistical measurement of the existing utilization.
Q12	octet Synonym for byte: 1 octet = 8 bit = 1 byte.
Q13	octet per second Unit octet divided by the SI base unit second.
Q14	shannon Logarithmic unit for information equal to the content of decision of a sentence of two mutually exclusive events, expressed as a logarithm to base 2.

Used Codes

Q15	hartley Logarithmic unit for information equal to the content of decision of a sentence of ten mutually exclusive events, expressed as a logarithm to base 10.
Q16	natural unit of information Logarithmic unit for information equal to the content of decision of a sentence of ,718 281 828 459 mutually exclusive events, expressed as a logarithm to base Euler value e.
Q17	shannon per second Time related logarithmic unit for information equal to the content of decision of a sentence of two mutually exclusive events, expressed as a logarithm to base 2.
Q18	hartley per second Time related logarithmic unit for information equal to the content of decision of a sentence of ten mutually exclusive events, expressed as a logarithm to base 10.
Q19	natural unit of information per second Time related logarithmic unit for information equal to the content of decision of a sentence of 2,718 281 828 459 mutually exclusive events, expressed as a logarithm to base of the Euler value e.
Q20	second per kilogramm Unit of the Einstein transition probability for spontaneous or inducing emissions and absorption according to ISO 80000-7:2008, expressed as SI base unit second divided by the SI base unit kilogram.
Q21	watt square metre Unit of the first radiation constants $c_1 = 2 \cdot p \cdot h \cdot c_0$ to the power of 2, the value of which is 3,741 771 18·10 ¹⁶ -fold that of the comparative value of the product of the derived SI unit watt multiplied with the power of the SI base unit metre with the exponent 2.
Q22	second per radian cubic metre Unit of the density of states as an expression of angular frequency as complement of the product of hertz and radiant and the power of SI base unit metre by exponent 3 .
Q23	weber to the power minus one Complement of the derived SI unit weber as unit of the Josephson constant, which value is equal to the 384 597,891-fold of the reference value gigahertz divided by volt.
Q24	reciprocal inch Complement of the unit inch according to the Anglo-American and Imperial system of units.
Q25	dioptre Unit used at the statement of relative refractive indexes of optical systems as complement of the focal length with correspondence to: 1 dpt = 1/m.

Used Codes

Q26	one per one Value of the quotient from two physical units of the same kind as a numerator and denominator whereas the units are shortened mutually.
Q27	newton metre per metre Unit for length-related rotational moment as product of the derived SI unit newton and the SI base unit metre divided by the SI base unit metre.
Q28	kilogram per square metre pascal second Unit for the ability of a material to allow the transition of steam.
Q29	microgram per hectogram Microgram per hectogram.
Q3	meal A unit of count defining the number of meals (meal: an amount of food to be eaten on a single occasion).
Q30	pH (potential of Hydrogen) The activity of the (solvated) hydrogen ion (a logarithmic measure used to state the acidity or alkalinity of a chemical solution).
Q31	kilojoule per gram
Q32	femtolitre
Q33	picolitre
Q34	nanolitre
Q35	megawatts per minute A unit of power defining the total amount of bulk energy transferred or consumer per minute.
Q36	square metre per cubic metre A unit of the amount of surface area per unit volume of an object or collection of objects.
Q37	Standard cubic metre per day Standard cubic metre (temperature 15°C and pressure 1013.25 millibars) per day
Q38	Standard cubic metre per hour Standard cubic metre (temperature 15°C and pressure 1013.25 millibars) per hour
Q39	Normalized cubic metre per day Normalized cubic metre (temperature 0°C and pressure 1013.25 millibars) per day
Q40	Normalized cubic metre per hour Normalized cubic metre (temperature 0°C and pressure 1013.25 millibars) per hour

Used Codes

Q41	Joule per normalised cubic metre Joule per normalised cubic metre (temperature 0°C and pressure 1013.25 millibars).
Q42	Joule per standard cubic metre Joule per standard cubic metre (temperature 15°C and pressure 1013.25 millibars).
QA	page - facsimile A unit of count defining the number of facsimile pages.
QAN	quarter (of a year) A unit of time defining the number of quarters (3 months).
QB	page - hardcopy A unit of count defining the number of hardcopy pages (hardcopy page: a page rendered as printed or written output on paper, film, or other permanent medium).
QR	quire A unit of count for paper, expressed as the number of quires (quire: a number of paper sheets, typically 25).
QT	quart (US) Use liquid quart (common code QTL)
QTD	dry quart (US)
QTI	quart (UK)
QTL	liquid quart (US)
QTR	quarter (UK) A traditional unit of weight equal to 1/4 hundredweight. In the United Kingdom, one quarter equals 28 pounds.
R1	pica A unit of count defining the number of picas. (pica: typographical length equal to 12 points or 4.22 mm (approx.)).
R9	thousand cubic metre A unit of volume equal to one thousand cubic metres.
RH	running or operating hour A unit of time defining the number of hours of operation.
RM	ream A unit of count for paper, expressed as the number of reams (ream: a large quantity of paper sheets, typically 500).
ROM	room A unit of count defining the number of rooms.

Used Codes

RP	pound per ream A unit of mass for paper, expressed as pounds per ream. (ream: a large quantity of paper, typically 500 sheets).
RPM	revolutions per minute Refer ISO/TC12 SI Guide
RPS	revolutions per second Refer ISO/TC12 SI Guide
RT	revenue ton mile A unit of information typically used for billing purposes, expressed as the number of revenue tons (revenue ton: either a metric ton or a cubic metres, whichever is the larger), moved over a distance of one mile.
S3	square foot per second Synonym: foot squared per second
S4	square metre per second Synonym: metre squared per second (square metres/second US)
SAN	half year (6 months) 'A unit of time defining the number of half years (6 months).
SCO	score A unit of count defining the number of units in multiples of 20.
SCR	scruple
SEC	second [unit of time]
SET	set A unit of count defining the number of sets (set: a number of objects grouped together).
SG	segment A unit of information equal to 64000 bytes.
SHT	shipping ton A unit of mass defining the number of tons for shipping.
SIE	siemens
SM3	Standard cubic metre Standard cubic metre (temperature 15°C and pressure 1013.25 millibars)
SMI	mile (statute mile)
SQ	square A unit of count defining the number of squares (square: rectangular shape).
SQR	square, roofing A unit of count defining the number of squares of roofing materials, measured in multiples of 100 square feet.

Used Codes

SR	strip A unit of count defining the number of strips (strip: long narrow piece of an object).
STC	stick A unit of count defining the number of sticks (stick: slender and often cylindrical piece of a substance).
STI	stone (UK)
STK	stick, cigarette A unit of count defining the number of cigarettes in the smallest unit for stock-taking and/or duty computation.
STL	standard litre A unit of volume defining the number of litres of a product at a temperature of 15 degrees Celsius, especially in relation to hydrocarbon oils.
STN	ton (US) or short ton (UK/US) Synonym: net ton (2000 lb)
STW	straw A unit of count defining the number of straws (straw: a slender tube used for sucking up liquids).
SW	skein A unit of count defining the number of skeins (skein: a loosely-coiled bundle of yarn or thread).
SX	shipment A unit of count defining the number of shipments (shipment: an amount of goods shipped or transported).
SYR	syringe A unit of count defining the number of syringes (syringe: a small device for pumping, spraying and/or injecting liquids through a small aperture).
T0	telecommunication line in service A unit of count defining the number of lines in service.
T3	thousand piece A unit of count defining the number of pieces in multiples of 1000 (piece: a single item, article or exemplar).
TAH	kiloampere hour (thousand ampere hour)
TAN	total acid number A unit of chemistry defining the amount of potassium hydroxide (KOH) in milligrams that is needed to neutralize the acids in one gram of oil. It is an important quality measurement of crude oil.
TI	thousand square inch

Used Codes

TIC	metric ton, including container A unit of mass defining the number of metric tons of a product, including its container.
TIP	metric ton, including inner packaging A unit of mass defining the number of metric tons of a product, including its inner packaging materials.
TKM	tonne kilometre A unit of information typically used for billing purposes, expressed as the number of tonnes (metric tons) moved over a distance of one kilometre.
TMS	kilogram of imported meat, less offal A unit of mass equal to one thousand grams of imported meat, disregarding less valuable by-products such as the entrails.
TNE	tonne (metric ton) Synonym: metric ton
TP	ten pack A unit of count defining the number of items in multiples of 10.
TPI	teeth per inch The number of teeth per inch.
TPR	ten pair A unit of count defining the number of pairs in multiples of 10 (pair: item described by two's).
TQD	thousand cubic metre per day A unit of volume equal to one thousand cubic metres per day.
TRL	trillion (EUR)
TST	ten set A unit of count defining the number of sets in multiples of 10 (set: a number of objects grouped together).
TTS	ten thousand sticks A unit of count defining the number of sticks in multiples of 10000 (stick: slender and often cylindrical piece of a substance).
U1	treatment A unit of count defining the number of treatments (treatment: subjection to the action of a chemical, physical or biological agent).
U2	tablet A unit of count defining the number of tablets (tablet: a small flat or compressed solid object).
UA	torr
UB	telecommunication line in service average A unit of count defining the average number of lines in service.

Used Codes

UC	telecommunication port A unit of count defining the number of network access ports.
UIG	international unit per gram A unit of count defining the number of international units per gram.
VA	volt - ampere per kilogram
VLT	volt
VP	percent volume A measure of concentration, typically expressed as the percentage volume of a solute in a solution.
W2	wet kilo A unit of mass defining the number of kilograms of a product, including the water content of the product.
WA	watt per kilogram
WB	wet pound A unit of mass defining the number of pounds of a material, including the water content of the material.
WCD	cord A unit of volume used for measuring lumber. One board foot equals 1/12 of a cubic foot.
WE	wet ton A unit of mass defining the number of tons of a material, including the water content of the material.
WEB	weber
WEE	week
WG	wine gallon A unit of volume equal to 231 cubic inches.
WHR	watt hour
WM	working month A unit of time defining the number of working months.
WSD	standard A unit of volume of finished lumber equal to 165 cubic feet. Synonym: standard cubic foot
WTT	watt
WW	millilitre of water A unit of volume equal to the number of millilitres of water.
X1	Gunter's chain A unit of distance used or formerly used by British surveyors.
YDK	square yard

Used Codes

YDQ	cubic yard
YRD	yard
Z11	hanging container A unit of count defining the number of hanging containers.
Z9	nanomole An SI unit of amount of substance equal to 10 ⁻⁹ moles
ZP	page A unit of count defining the number of pages.
ZZ	mutually defined A unit of measure as agreed in common between two or more parties.
001	Barrel (205 litres, 45 gallons) (GS1 Temporary Code) A unit of liquids equivalent to 205 litres or 45 gallons.
23	gram per cubic centimetre GS1 Description: g/cm ³ as a unit of measure for the density of gas. This is necessary for dangerous substance articles for determination of the quantities that can be stored together on the shelf.
25	gram per square centimetre GS1 Description: A measure of weight in terms of gram per square centimetre.
28	kilogram per square metre GS1 Description: Unit of measure expressed in kilogram per square metre.
37	ounce per square foot
59	part per million
64	Pound per square inch, gauge A unit of measure expressed in pound per square inch
2N	decibel
2X	metre per minute GS1 Description: A measure of speed in terms of metres per minute.
4K	milliampere
4L	megabyte GS1 Description: A unit of computer memory equal to 1.048.576 (i.e. 2 power 20) bytes.
40	microfarad GS1 Description: One millionth of a farad. A farad is the capacitance of a capacitor between the plates of which a potential of 1 volt is created by a charge of 1 Coulomb.
4P	newton per metre

Used Codes

A25	cheval vapeur
A86	gigahertz GS1 Description: Hertz multiplied by 10*9.
A99	Bit A unit of information equal to one binary digit.
ACR	acre GS1 Description: Acre (4840 yd2)
AD	byte GS1 Description: A unit of information stored in a computer, equal to eight bits.
AMH	ampere hour GS1 Description: Ampere-hour (3,6kC)
AMP	ampere
AMT	amount
ANN	year GS1 Description: The expression of a year as a measure unit.
APZ	Troy ounce or apothecary ounce EDIFACT
ASM	alcoholic strength by mass GS1 Description: Alcoholic strength expressed by mass.
ASU	alcoholic strength by volume GS1 Description: Alcoholic strength expressed by volume.
AV	capsule GS1 Description: Encapsuled dosage form for pharmaceuticals.
B13	Joule per square metre A unit of measure of heat energy expressed in joule per square metre.
B17	Credit A unit of count defining the number of entries made to the credit side of an account.
BAR	bar GS1 Description: A unit of measure equal to 106 dines per square centimeter.
BTU	British thermal unit GS1 Description: British thermal unit (1,055 kilojoules)

Used Codes

C0	call GS1 Description: Unit of measure for telephone calls. Code value is C0 (C Zero).
C60	ohm centimetre GS1 Description: Unit of measure expressed in Ohm centimetre.
C79	Kilovolt Ampere Hour A unit of accumulated energy of 1000 volt amperes over a period of one hour. EDIFACT
CDL	candela GS1 Description: Unit of measure of light intensity.
CEL	degree celsius
CF2	Colony forming unit per gram (GS1 Temporary Code) Colony forming units per gram is a unit of measure for micro-organisms, such as bacteria, in a food item. Micro-organisms form colonies that are be counted under determined conditions
CLT	centilitre GS1 Description: A unit of volume equal to one hundredth of a liter.
CMK	square centimetre
CMQ	cubic centimetre GS1 Description: A system of units for the measurement of volume based on the cubic centimetre.
CMT	centimetre
D19	Square metre kelvin per watt Unit of measure of thermal insulance expressed in square metre kelvin per watt.
D21	square metre per kilogram GS1 Description: Unit of measure expressed in square metre per kilogram.
D32	Terawatt hour A unit of measure expressed in terawatt hour
D5	Kilogram per square centimetre A unit of measure expressed in kilogram per square centimetre
D55	Watt per square metre kelvin Unit of measure of thermal conductance expressed in watt per square metre kelvin.
D68	Number of Words A unit of count defining the number of words. EDIFACT

Used Codes

DAY	day GS1 Description: The expression of a day as a measure unit.
DD	degree GS1 Description: Unit of measure of temperature.
DMQ	cubic decimetre GS1 Description: Unit of measure expressed in cubic decimetre.
DMT	decimetre
DRG	Dragée (GS1 Temporary Code) Number of dragées (coated tablets) contained in the item's package as a measurement unit.
DZN	dozen GS1 Description: A unit of measure of 12 or group of 12.
E09	Milliampere hour A unit of power load delivered at the rate of one thousandth of an ampere over a period of one hour. EDIFACT
E10	Degree day A unit of measure used in meteorology and engineering to measure the demand for heating or cooling over a given period of days. EDIFACT
E11	Gigacalorie A unit of heat energy equal to one thousand million calories. EDIFACT
E27	Dose A unit of count defining the number of doses (dose: a definite quantity of a medicine or drug). EDIFACT
E31	Square metre per litre A unit of count defining the number of square metres per litre. EDIFACT
E32	Litre per hour A unit of count defining the number of litres per hour. EDIFACT
E34	Gigabyte A unit of information equal to 10 E9 bytes.
E37	Pixel A unit of count defining the number of pixels (pixel: picture element).

Used Codes

E38	Megapixel A unit of count equal to 10 E6 (1000000) pixels (picture elements).
E39	Dots per inch A unit of information defining the number of dots per linear inch as a measure of the resolution or sharpness of an image. GS1 Description: synonym: pixels per inch.
EA	each
EV	envelope GS1 Description: A unit of measure pertaining to the number of envelopes.
FAH	degree Fahrenheit
FOT	foot GS1 Description: Foot (0,3048 m)
FP	Pound per square foot A unit of measure expressed in pound per square foot
FTK	Square foot A unit of measure expressed in square foot
FTQ	cubic foot
GL	gram per litre
GLI	gallon (UK) GS1 Description: Gallon (4,546092 dm ³)
GM	gram per square metre GS1 Description: Unit of measure of grams per square metre.
GRM	gram
GRO	gross GS1 Description: A unit of measure of 12 dozens.
GV	gigajoule
GWH	gigawatt hour GS1 Description: Gigawatt-hour (1 million kW/h)
H87	Piece A unit of count defining the number of pieces (piece: a single item, article or exemplar). EDIFACT
HLT	hectolitre

Used Codes

HMT	hectometre A unit of linear measure equal to 10 E2 metres.
HTZ	hertz GS1 Description: One cycle per second.
HUR	hour
INH	inch GS1 Description: Inch (25,4 mm)
INK	Square inch A unit of measure expressed in square inch
JM	Megajoule per cubic metre EDIFACT
JOU	joule
K51	Kilocalorie (mean) EDIFACT
KB	kilocharacter
KBA	kilobar
KEL	kelvin
KGM	kilogram
KHZ	kilohertz
KJO	kilojoule
KL	kilogram per metre GS1 Description: A measure of weight in terms of kilogram per metre.
KMH	kilometre per hour GS1 Description: A unit of measure expressed in kilometre per hour.
KMQ	kilogram per cubic metre GS1 Description: A measure of weight in terms of kilogram per cubic metre.
KMT	kilometre
KPA	kilopascal GS1 Description: Unit of measure expressed in kilopascal.
KVA	kilovolt - ampere GS1 Description: A unit of electric power.
KVT	kilovolt
KWH	kilowatt hour

Used Codes

KWT	kilowatt
L2	litre per minute GS1 Description: Unit of measure expressed in litre per minute.
LBR	Pound EDIFACT
LD	Litre per day A unit of measure defining the number of litres per day.
LNE	Printed line count (GS1 Temporary Code) The indication of the count of printed lines included on a paper communication (e.g. telegram) for invoicing purposes.
LTR	litre GS1 Description: Litre (1 dm ³)
LUX	lux GS1 Description: Unit of measure of illumination (it corresponds to the illumination of a surface which normally and uniformly receives a light flow of 1 lumen per square meter).
M4	Monetary value A unit of measure expressed as a monetary amount. EDIFACT
MAL	mega litre
MAW	megawatt
MC	microgram One millionth of a gram.
MCU	millicurie GS1 Description: Unit of measure for radioactivity.
MGM	milligram
MHZ	megahertz
MIN	minute
MLT	millilitre
MMK	square millimetre GS1 Description: A unit to measure a surface equal to one millionth of a quadrate.
MMQ	cubic millimetre GS1 Description: A unit of measure expressed in cubic milimetres.
MMT	millimetre

Used Codes

MON	month GS1 Description: The expression of a month as a measure unit.
MPA	megapascal GS1 Description: A unit of measure expressed in Megapascal.
MQH	Cubic metre per hour A unit of measure defining the number of cubic metres per hour.
MTK	square metre
MTQ	cubic metre
MTR	metre
MTS	Metre per second A unit of speed expressed in metres per second.
MWH	megawatt hour (1000 kW.h)
NAR	number of articles
NEW	newton GS1 Description: The SI unit of force, equal to the force that would give a mass of one kilogram an acceleration of one metre per second.
NIU	number of international units A unit of count defining the number of international units.
NRL	number of rolls
ONZ	ounce GS1 Description: Ounce GB, US (28,349523 g)
OZA	fluid ounce (US) GS1 Description: Fluid ounce US (29,5735 cm ³)
OZI	fluid ounce (UK) GS1 Description: Fluid ounce UK (28,413 cm ³)
P1	percent GS1 Description: This code is used to indicate measurements in terms of percentages, e.g. the relative humidity (code RA in data element 6313) is 52%.
PA	packet
PAL	pascal GS1 Description: The SI unit of pressure, equal to one Newton per square metre.
PCE	Piece (GS1 Temporary Code) GS1 Note: Old code value. Use value H87 instead.

Used Codes

PF	pallet (lift) GS1 Description: A number of articles expressed in terms of pallets.
PR	pair GS1 Description: Two articles which belong together but are not necessarily identical.
PTI	pint (UK) GS1 Description: Pint UK (0,568262 dm3)
PTN	Portion (GS1 Temporary Code) The identification of the number of portions (doses in medical terms) into which a complete product may be broken into for serving purposes, e.g. a pie with 6 portions, a liquid medicine with 20 doses.
QAN	quarter (of a year)
QTI	quart (UK) GS1 Description: Quart UK (1,1136523 dm3)
RJH	Decanewton (GS1 Temporary Code) A unit of force equal to 10 Newton.
RPM	revolutions per minute
RTO	Ratio (GS1 Temporary Code) The measured value is a ratio.
SEC	second
SMI	Mile (statute mile) A unit of measure expressed in mile
ST	sheet
TNE	tonne (metric ton) GS1 Description: Metric ton (1000kg)
U2	tablet A unit of count defining the number of tablets (tablet: a small flat or compressed solid object). GS1 Description: Dosage form for pharmaceuticals, pressed or compacted from a powder into a solid dose.
UI	Unit of activity, predefined (GS1 Temporary Code) A measure pertaining to a predefined activity.
VI	vial GS1 Description: Small glass container. E.g. for a liquid medicine or perfume.
VLT	volt

Used Codes

WHR	watt hour
WTT	watt
YDK	Square yard A unit of measure expressed in square yard
YRD	yard GS1 Description: Yard (0,9144 m)
ZP	page GS1 Description: The indication of a page as a measurement unit for invoicing purposes, e.g. fax pages.
7009	Item description code Code specifying an item.
ACA	ABC Method - Classification A (GS1 Permanent Code) Activity based on costing classification method A.
ACB	ABC Method - Classification B (GS1 Permanent Code) Activity based on costing classification method B.
ACC	ABC Method - Classification C (GS1 Permanent Code) Activity based on costing classification method C.
AUT	Autumn (GS1 Permanent Code) Autumn season.
BA	Base article (GS1 Permanent Code) A conceptual article identified for the purposes of ordering Customer Specific Articles. Base articles must always have configurations of options associated with them.
BLK	Bulk consumer unit (GS1 Permanent Code) The item is designed as a bulk consumer unit, i.e. to be sold mainly to hotels, restaurants, caterers, hospitals etc.
BU	Base unit (GS1 Permanent Code) The lowest level packaged unit for a given product, which may or may not be the consumer unit.
CA	Case (GS1 Permanent Code) A standard trade item shipping unit.
CIT	Collateral Item (GS1 Permanent Code) A trade item delivered from a manufacturer to the retail selling floor that is not considered inventory and has no retail value.
CMP	Composition (GS1 Permanent Code) The item is included in a dynamic assortment.

Used Codes

CSF	Display material (GS1 Permanent Code) A shopping unit that is a display.
CSG	Full display stand (GS1 Permanent Code) A trade item given to a consumer as part of a promotional event on another item or items.
CTO	Cut to order (GS1 Permanent Code) A unit load that is a "display ready pallet" and is intended to go directly to the selling floor.
CU	Consumer unit (GS1 Permanent Code) A group of trade items (the same or different) that are intended to be sold as a single consumer unit at the Point-of-Sale.
D	Available all the year round (GS1 Permanent Code) A unit load that could contain multiple packages.
DAS	Dynamic Assortment (GS1 Permanent Code) The item is included in a dynamic assortment.
DF	Default (GS1 Permanent Code) A logistical unit or a consumer unit between a case and a each.
DIC	Discount coupon (GS1 Permanent Code) A coupon that entitles to a discount.
DSP	Display shipper (GS1 Permanent Code) A shopping unit that is a display.
DST	Display stand (GS1 Permanent Code) A trade item given to a consumer as part of a promotional event on another item or items.
DU	Despatch unit (GS1 Permanent Code) The package size of a product or products which may be shipped when fulfilling an order.
ETO	Engineer to Order (GS1 Permanent Code) Engineer to Order includes products that are designed, developed and manufactured in response to a specific customer request.
F01	Caught (GS1 Permanent Code) Caught at sea
F02	Caught in freshwater (GS1 Permanent Code) Caught in freshwater
F03	Farmed (GS1 Permanent Code) Farmed
F04	Cultivated (GS1 Permanent Code) Cultivated

Used Codes

FEM	Female (GS1 Permanent Code) Female gender.
FS	Available in spring-summer (GS1 Permanent Code) The product is available in the spring-summer period.
FZ1	Previously frozen (GS1 Permanent Code) Previously frozen
FZ2	Not previously frozen (GS1 Permanent Code) Not previously frozen
GWP	Gift with purchase (GS1 Permanent Code) A trade item given to a consumer as part of a promotional event on another item or items.
HN	Handling unit (GS1 Permanent Code) The package size of a product which will be used when transporting and storing the product.
HW	Available in autumn-winter (GS1 Permanent Code) The product is available in the autumn-winter period.
IF1	IF <> THEN <> ENDIF (GS1 Permanent Code) E.G., IF <customer chooses node number 1332> THEN <action (taken from DE 1229 of LIN) to node number 1773> ENDIF.
IF2	IF NOT <> THEN <> ENDIF (GS1 CPermanent ode) E.G., IF NOT <customer does not choose node number 1332> THEN <action (taken from DE 1229 of LIN) to node number 1773> ENDIF.
IF3	IF <> AND (GS1 Permanent Code) E.G., IF <customer chooses node number 1332> AND (followed by another repeat of IMD with another rule).
IF4	IF NOT <> AND (GS1 Permanent Code) E.G., IF NOT <customer does not choose node number 1332> AND (followed by another repeat of IMD with another rule).
IF5	IF <> OR (GS1 Permanent Code) E.G., IF <customer chooses node number 1332> OR (followed by another repeat of IMD with another rule).
IF6	IF NOT <> OR (GS1 Permanent Code) E.G., IF NOT <customer does not choose node number 1332> OR (followed by another repeat of IMD with another rule).
IF7	IF <> XOR (GS1 Permanent Code) E.G., IF <customer chooses node number 1332> XOR (followed by another repeat of IMD with another rule).
IF8	IF NOT <> XOR (GS1 Permanent Code) E.G., IF NOT <customer does not choose node number 1332> XOR (followed by another repeat of IMD with another rule).

Used Codes

IN	Invoicing unit (GS1 Permanent Code) The package size of a product or products which will be used as the unit on which the buyer is invoiced.
IT	Intermediate unit (GS1 Permanent Code) A package size of a product or products falling in between two predefined package sizes.
MA	Mandatory (GS1 Permanent Code) An option of a Customer Specific Article which is mandatory in the configuration of the base article, e.g. it is mandatory to have legs when ordering a CSA table.
MAL	Male (GS1 Permanent Code) Male gender.
MM	Mixed module (GS1 Permanent Code) A unit load that is a "display ready pallet" and is intended to go directly to the selling floor.
MOD	Model (GS1 Permanent Code) The identification of an article as a high level model of a product, e.g. spring fashions.
MP	Multipack (GS1 Permanent Code) A group of trade items (the same or different) that are intended to be sold as a single consumer unit at the Point-of-Sale.
MTO	Make to Order (GS1 Permanent Code) A Make to Order environment is one in which products are completed after receipt of a customer order and are built or configured only in response to a customer order.
MTS	Make to Stock (GS1 Permanent Code) Make to Stock products are intended to be shipped from finished goods or 'off the shelf', are completed prior to receipt of a customer order, and are generally produced in accordance with sales forecasts.
NAR	Next Article (GS1 Permanent Code) An indication that what follows is a set of linked articles, a certain number of these linked articles should be chosen.
NBU	Not a base unit (GS1 Permanent Code) Not the lowest level packaged unit for a given product, which may or may not be the consumer unit.
NCU	Not a consumer unit (GS1 Permanent Code) The current base item or packaging item is not a consumer unit, i.e. is not a pre-packaging that is intended and labelled or marked for consumers according to legal requirements.
ND	Non divisible item (GS1 Permanent Code) The item is not divisible.

Used Codes

NDU	Not a despatch unit (GS1 Permanent Code) The current base item or packaging item is not a regular logistical despatch unit, i.e. it is as a rule only delivered as many within a further repackaging, and not as an individual logistics item.
NFR	Not For Resale (GS1 Permanent Code) Item is not for resale to consumer.
NIN	Not an invoicing unit (GS1 Permanent Code) The current base item or packaging item is not an invoicing unit of the data supplier, i.e. cannot be invoiced individually but only as one of many in a repackaging or transport packaging item.
NLK	Not a bulk consumer unit (GS1 Permanent Code) The item is not designed as a bulk consumer unit, i.e. to be sold mainly to hotels, restaurants, caterers, hospitals etc.
NO	Not an ordering unit (GS1 Permanent Code) A package size of a product or products which may not be ordered.
NOS	Yes, NOS item (GS1 Permanent Code) The current item is an NOS (Never out of stock) article, that is continuously reordered and replenished.
NOT	Not, not an NOS item (GS1 Permanent Code) The current item is not an NOS (Never out of stock) article, therefore is not continuously reordered and replenished.
NOV	Next option value (GS1 Permanent Code) An indication that what follows is a set of linked option values, next option values, or parameters.
NPC	Reusable container, but not standardized by a pool cooperative (GS1 Permanent Code) Reusable container that is not standardized by a pool cooperative.
NRC	Non-returnable container (GS1 Permanent Code) The current product is not traditionally a traded product and does not need to be returned to the sender.
NRE	Not a retail product (GS1 Permanent Code) The current item is not meant for retail sale, but only for sale to hotels, restaurants and catering.
NS	Not smallest unit (GS1 Permanent Code) Not the smallest unit for a given product.
NSU	Non-standard unit (GS1 Permanent Code) Products grouped together to fulfil specific ordering needs and not generally available.
NVQ	Not a variable quantity product (GS1 Permanent Code) The current item is a variable weight trade item, for which the weight and the quantity is determined only by the buyer.

Used Codes

OP	Option (GS1 Permanent Code) An option within a Customer Specific Article which does not exist on its own, e.g. colour, and which has discrete values.
OPL	Overall product level (GS1 Permanent Code) An overall level whereby many products are grouped on the basis of their composition, application and characteristics (e.g. Coca Cola with no size, packaging, price, etc, specified).
OPV	Option value (GS1 Permanent Code) The result of a choice of an option. The option value will be the lowest level of a branch beneath an option structure.
ORU	Ordering unit (GS1 Permanent Code) Indication that the current product is an ordering unit (ordering unit will not normally equal invoicing unit).
PA	Numeric parameter (GS1 Permanent Code) An option of a Customer Specific Article which has a continuous numeric value, e.g., measurement of the length of a chair leg between 60cms and 80cms.
PAA	Alpha-numeric parameter (GS1 Permanent Code) An option of a Customer Specific Article which has a continuous alpha-numeric value, e.g., words and numbers to be embroidered into a cushion cover.
PAD	Promotional article description (GS1 Permanent Code) Description of a promotional article.
PAL	Pallet (GS1 Permanent Code) A unit load that could contain multiple packages.
PAS	Prepack assortment (GS1 Permanent Code) Contains multiple components, each of which represents a unique consumer unit item.
PIP	Packer or inner pack (GS1 Permanent Code) A logistical unit or a consumer unit between a case and a each.
PPK	Prepack (GS1 Permanent Code) Contains multiple components, each of which represents a unique consumer unit item.
PR1	Bonus Pack (GS1 Permanent Code) The free quantity promotional trade item contains free additional quantities. The additional quantity is written on the package as free.
PR2	Free components (GS1 Permanent Code) It contains free included components or material. The price is lower since the trade item includes a part of its content free. The free quantity is written on the package.

Used Codes

PR3	Free quantity (GS1 Permanent Code) It contains free quantity, a "special offer" sticker on the package indicates the promotional offer but the free quantity is not written on the package. If the free quantity promotional offer results in a change of GTIN and the quantity of product is the same as the standard trade item, it qualifies as a free quantity promotional trade item. The linkage has to be provided.
PR4	Multi-pack and combination pack (GS1 Permanent Code) It is a promotional grouping with included free quantity. The grouping is created for promotional activities only. In the grouping a part of the quantity is free.
PRO	Programme (GS1 Permanent Code) A programme within a Customer Specific Article which does not exist on its own.
PWP	Purchase with purchase (GS1 Permanent Code) A trade item sold to a consumer at a special price as part of a promotional event, contingent on the consumer purchasing another item or items.
RC	Returnable container (GS1 Permanent Code) The current product is not traditionally a traded product but one which should be returned according to separate instructions.
RD	Refundable deposit item (GS1 Permanent Code) Item is subject to a refundable deposit.
RE	Retail product (GS1 Permanent Code) The current item is meant for retail sale only, and not for sale to hotels, restaurants and catering.
RPC	Reusable pool container (GS1 Permanent Code) Reusable container standardized by a pool cooperative.
SER	Service (GS1 Permanent Code) A code identifying the current item as a service (i.e. not a physical product).
SG	Standard group of products (mixed assortment) (GS1 Permanent Code) A standard package containing different products enabling the package to be ordered, delivered and invoiced.
SMR	Summer (GS1 Permanent Code) Summer season.
SPK	Setpack (GS1 Permanent Code) Contains multiple components, each of which represents a unique consumer unit item.
SPR	Spring (GS1 Permanent Code) Spring season.
SU	Smallest unit (GS1 Permanent Code) The smallest usable or tradeable size or unit for a given product.

Used Codes

TU	Traded unit (GS1 Permanent Code) The package size of a product or products which has been agreed by trading partners as the size which may be ordered, delivered and invoiced.
UNI	Unisex (GS1 Permanent Code) No gender.
VQ	Variable quantity product (GS1 Permanent Code) Product is used or traded in continuous rather than discrete quantities.
WNT	Winter (GS1 Permanent Code) Winter season.
XX1	Count (GS1 Permanent Code) The measure applied to price is count.
XX2	Area (GS1 Permanent Code) The measure applied to price is area.
XX3	Weight (GS1 Permanent Code) The measure applied to price is weight.
XX4	Volume (GS1 Permanent Code) The measure applied to price is volume.
XX5	Length (GS1 Permanent Code) The measure applied to price is length.
XX6	Loose (GS1 Permanent Code) A trade item which is without packaging at the retail level.
XX7	Pre-packed (GS1 Permanent Code) A variable-measure trade item which is provided with packaging that is assembled or produced by the supplier or by the retailer in advance of sale to the consumer.
XX8	Fixed discount coupon on item price (GS1 Permanent Code) A discount coupon that can be redeemed at the point of sale for a fixed amount when purchasing a specific item/brand/range.
XX9	Fixed discount coupon on purchase amount (GS1 Permanent Code) A discount coupon that can be redeemed at the point of sale for a fixed amount on the total amount of the purchase.
XY1	Percentage discount on item price (GS1 Permanent Code) A discount coupon that can be redeemed at the point of sale for a percentage of the specific item/brand/range value.
XY2	Percentage discount on purchase amount (GS1 Permanent Code) A discount coupon that can be redeemed at the point of sale for a percentage of the total amount of the purchase.
XY3	Meal voucher (GS1 Permanent Code) Fixed amount voucher that can be redeemed at foodservice industry.

Used Codes

XY4	Limited Edition (GS1 Permanent Code) A product with limited edition is restricted in the number of copies produced, although in fact the number may be very low or very high. A special edition implies there is extra material of some kind included.
XY5	One Shot Product (GS1 Permanent Code) The trading partners agree to supply/buy this product only once. Afterwards this product will not be supplied/bought any more.
XY6	Fee (GS1 Permanent Code) Code identify the GTIN of LIN segment as being fees.
XY7	Brokerage (GS1 Permanent Code) Code identify the GTIN of LIN segment as being brokerages.
XY8	Transport medium unit (GS1 Permanent Code) Code identify the position as a Transport Medium Unit (Pallet, Container,).
XY9	Counted measurand factor (GS1 Permanent Code) Factor for price calculation of energy products, e.g. gas, fuel.
XZ1	Standard condition conversion (GS1 Permanent Code) The ratio of a product volume (e.g. gas) in standard conditions to the volume in the operating state.
XZ2	Calorific value (GS1 Permanent Code) The calorific value of a fuel indicates the amount of heat generated by the combustion and subsequent cooling of the combustion gases at 25 degrees Celsius.
XZ3	Food contact allowed (GS1 Temporary Code) The trade item is allowed to have direct contact with food.
XZ4	Food contact not allowed (GS1 Temporary Code) The trade item is not allowed to have direct contact with food.
7065	Package type description code Code specifying the type of package. Notes: 1. Recommend use UN/ECE Recommendation No. 21 (also, see current volume of UNTDED).
43	Bag, super bulk
44	Bag, polybag A type of plastic bag, typically used to wrap promotional pieces, publications, product samples, and/or catalogues.
1A	Drum, steel
1B	Drum, aluminium
1D	Drum, plywood

Used Codes

1F	Container, flexible A packaging container of flexible construction.
1G	Drum, fibre
1W	Drum, wooden
2C	Barrel, wooden
3A	Jerrican, steel
3H	Jerrican, plastic
4A	Box, steel
4B	Box, aluminium
4C	Box, natural wood
4D	Box, plywood
4F	Box, reconstituted wood
4G	Box, fibreboard
4H	Box, plastic
5H	Bag, woven plastic
5L	Bag, textile
5M	Bag, paper
6H	Composite packaging, plastic receptacle
6P	Composite packaging, glass receptacle
7A	Case, car A type of portable container designed to store equipment for carriage in an automobile.
7B	Case, wooden A case made of wood for retaining substances or articles.
8A	Pallet, wooden A platform or open-ended box, made of wood, on which goods are retained for ease of mechanical handling during transport and storage.
8B	Crate, wooden A receptacle, made of wood, on which goods are retained for ease of mechanical handling during transport and storage.
8C	Bundle, wooden Loose or unpacked pieces of wood tied or wrapped together.
AA	Intermediate bulk container, rigid plastic
AB	Receptacle, fibre
AC	Receptacle, paper

Used Codes

AD	Receptacle, wooden
AE	Aerosol
AF	Pallet, modular, collars 80cms × 60cms
AG	Pallet, shrinkwrapped
AH	Pallet, 100cms × 110cms
AI	Clamshell
AJ	Cone
AL	Ball A spherical containment vessel for retaining substances or articles.
AM	Ampoule, non-protected
AP	Ampoule, protected
AT	Atomizer
AV	Capsule
B4	Belt A band use to retain multiple articles together.
BA	Barrel
BB	Bobbin
BC	Bottlecrate / bottlerack
BD	Board
BE	Bundle
BF	Balloon, non-protected
BG	Bag
BH	Bunch
BI	Bin
BJ	Bucket
BK	Basket
BL	Bale, compressed
BM	Basin
BN	Bale, non-compressed
BO	Bottle, non-protected, cylindrical
BP	Balloon, protected
BQ	Bottle, protected cylindrical
BR	Bar
BS	Bottle, non-protected, bulbous

Used Codes

BT	Bolt
BU	Butt
BV	Bottle, protected bulbous
BW	Box, for liquids
BX	Box
BY	Board, in bundle/bunch/truss
BZ	Bars, in bundle/bunch/truss
CA	Can, rectangular
CB	Crate, beer
CC	Churn
CD	Can, with handle and spout
CE	Creel
CF	Coffer
CG	Cage
CH	Chest
CI	Canister
CJ	Coffin
CK	Cask
CL	Coil
CM	Card
CN	Container, not otherwise specified as transport equipment
CO	Carboy, non-protected
CP	Carboy, protected
CQ	Cartridge
CR	Crate
CS	Case
CT	Carton
CU	Cup
CV	Cover
CW	Cage, roll
CX	Can, cylindrical
CY	Cylinder
CZ	Canvas

Used Codes

DA	Crate, multiple layer, plastic
DB	Crate, multiple layer, wooden
DC	Crate, multiple layer, cardboard
DG	Cage, Commonwealth Handling Equipment Pool (CHEP)
DH	Box, Commonwealth Handling Equipment Pool (CHEP), Eurobox
DI	Drum, iron
DJ	Demijohn, non-protected
DK	Crate, bulk, cardboard
DL	Crate, bulk, plastic
DM	Crate, bulk, wooden
DN	Dispenser
DP	Demijohn, protected
DR	Drum
DS	Tray, one layer no cover, plastic
DT	Tray, one layer no cover, wooden
DU	Tray, one layer no cover, polystyrene
DV	Tray, one layer no cover, cardboard
DW	Tray, two layers no cover, plastic tray
DX	Tray, two layers no cover, wooden
DY	Tray, two layers no cover, cardboard
EC	Bag, plastic
ED	Case, with pallet base
EE	Case, with pallet base, wooden
EF	Case, with pallet base, cardboard
EG	Case, with pallet base, plastic
EH	Case, with pallet base, metal
EI	Case, isothermic
EN	Envelope
FB	Flexibag A flexible containment bag made of plastic, typically for the transportation bulk non-hazardous cargoes using standard size shipping containers.
FC	Crate, fruit
FD	Crate, framed

Used Codes

FE	Flexitank A flexible containment tank made of plastic, typically for the transportation bulk non-hazardous cargoes using standard size shipping containers.
FI	Firkin
FL	Flask
FO	Footlocker
FP	Filmpack
FR	Frame
FT	Foodtainer
FW	Cart, flatbed Wheeled flat bedded device on which trays or other regular shaped items are packed for transportation purposes.
FX	Bag, flexible container
GB	Bottle, gas
GI	Girder
GL	Container, gallon A container with a capacity of one gallon.
GR	Receptacle, glass
GU	Tray, containing horizontally stacked flat items Tray containing flat items stacked on top of one another.
GY	Bag, gunny A sack made of gunny or burlap, used for transporting coarse commodities, such as grains, potatoes, and other agricultural products.
GZ	Girders, in bundle/bunch/truss
HA	Basket, with handle, plastic
HB	Basket, with handle, wooden
HC	Basket, with handle, cardboard
HG	Hogshead
HN	Hanger A purpose shaped device with a hook at the top for hanging items from a rail.
HR	Hamper
IA	Package, display, wooden
IB	Package, display, cardboard
IC	Package, display, plastic
ID	Package, display, metal

Used Codes

IE	Package, show
IF	Package, flow
IG	Package, paper wrapped
IH	Drum, plastic
IK	Package, cardboard, with bottle grip-holes
IL	Tray, rigid, lidded stackable (CEN TS 14482:2002) Lidded stackable rigid tray compliant with CEN TS 14482:2002.
IN	Ingot
IZ	Ingots, in bundle/bunch/truss
JB	Bag, jumbo A flexible containment bag, widely used for storage, transportation and handling of powder, flake or granular materials. Typically constructed from woven polypropylene (PP) fabric in the form of cubic bags.
JC	Jerrican, rectangular
JG	Jug
JR	Jar
JT	Jutebag
JY	Jerrican, cylindrical
KG	Keg
KI	Kit A set of articles or implements used for a specific purpose.
LE	Luggage A collection of bags, cases and/or containers which hold personal belongings for a journey.
LG	Log
LT	Lot
LU	Lug A wooden box for the transportation and storage of fruit or vegetables.
LV	Liftvan
LZ	Logs, in bundle/bunch/truss
MA	Crate, metal Containment box made of metal for retaining substances or articles.
MB	Bag, multiply
MC	Crate, milk

Used Codes

ME	Container, metal A type of containment box made of metal for retaining substances or articles, not otherwise specified as transport equipment.
MR	Receptacle, metal
MS	Sack, multi-wall
MT	Mat
MW	Receptacle, plastic wrapped
MX	Matchbox
NA	Not available
NE	Unpacked or unpackaged
NF	Unpacked or unpackaged, single unit
NG	Unpacked or unpackaged, multiple units
NS	Nest
NT	Net
NU	Net, tube, plastic
NV	Net, tube, textile
O1	Two sided cage on wheels with fixing strap A two sided cage mounted on wheels with fixing strap. Dimensions: 900 x 770 x 1513 cm (length x width x height).
O2	Trolley A low cart for the transportation and storage of groceries, milk, etc.
O3	Oneway pallet ISO 0 - 1/2 EURO Pallet Oneway pallet with dimensions 80 X 60 cm.
O4	Oneway pallet ISO 1 - 1/1 EURO Pallet Oneway pallet with dimensions 80 X 120 cm.
O5	Oneway pallet ISO 2 - 2/1 EURO Pallet Oneway pallet with dimensions 100 X 120 cm.
O6	Pallet with exceptional dimensions Pallet with non-standard dimensions.
O7	Wooden pallet 40 cm x 80 cm Wooden pallet with dimensions 40 cm x 80 cm.
O8	Plastic pallet SRS 60 cm x 80 cm SRS (Svenska Retursystem) standard synthetic pallet of dimensions 60 cm x 80 cm.
O9	Plastic pallet SRS 80 cm x 120 cm SRS (Svenska Retursystem) standard synthetic pallet of dimensions 80 cm x 120 cm.

Used Codes

OA	Pallet, CHEP 40 cm x 60 cm CHEP standard pallet of dimensions 40 centimeters x 60 centimeters.
OB	Pallet, CHEP 80 cm x 120 cm CHEP standard pallet of dimensions 80 centimeters x 120 centimeters.
OC	Pallet, CHEP 100 cm x 120 cm CHEP standard pallet of dimensions 100 centimeters x 120 centimeters.
OD	Pallet, AS 4068-1993 Australian standard pallet of dimensions 115.5 centimeters x 116.5 centimeters.
OE	Pallet, ISO T11 ISO standard pallet of dimensions 110 centimeters x 110 centimeters, prevalent in Asia - Pacific region.
OF	Platform, unspecified weight or dimension A pallet equivalent shipping platform of unknown dimensions or unknown weight.
OG	Pallet ISO 0 - 1/2 EURO Pallet Standard pallet with dimensions 80 X 60 cm.
OH	Pallet ISO 1 - 1/1 EURO Pallet Standard pallet with dimensions 80 X 120 cm.
OI	Pallet ISO 2 - 2/1 EURO Pallet Standard pallet with dimensions 100 X 120 cm.
OJ	1/4 EURO Pallet Standard pallet with dimensions 60 X 40 cm.
OK	Block A solid piece of a hard substance, such as granite, having one or more flat sides.
OL	1/8 EURO Pallet Standard pallet with dimensions 40 X 30 cm.
OM	Synthetic pallet ISO 1 A standard pallet with standard dimensions 80 x 120cm made of a synthetic material for hygienic reasons.
ON	Synthetic pallet ISO 2 A standard pallet with standard dimensions 100 x 120cm made of a synthetic material for hygienic reasons.
OP	Wholesaler pallet Pallet provided by the wholesaler.
OQ	Pallet 80 X 100 cm Pallet with dimensions 80 X 100 cm.

Used Codes

OR	Pallet 60 X 100 cm Pallet with dimensions 60 X 100 cm.
OS	Oneway pallet Pallet need not be returned to the point of expedition.
OT	Octabin A standard cardboard container of large dimensions for storing for example vegetables, granules of plastics or other dry products.
OU	Container, outer A type of containment box that serves as the outer shipping container, not otherwise specified as transport equipment.
OV	Returnable pallet Pallet must be returned to the point of expedition.
OW	Large bag, pallet sized A non-rigid container made of fabric, paper, plastic, etc, with an opening at the top which can be closed and which is suitable for use on pallets.
OX	A wheeled pallet with raised rim (81 x 67 x 135) A wheeled pallet with raised rim for the storing and transporting of loads. Dimensions: 81 x 67 x 135 cm (length x width x height).
OY	A wheeled pallet with raised rim (81 x 72 x 135) A wheeled pallet with raised rim for the storing and transporting of loads. Dimensions: 81 x 72 x 135 cm (length x width x height).
OZ	A wheeled pallet with raised rim (81 x 60 x 16) A wheeled pallet with raised rim for the storing and transporting of loads. Dimensions: 81 x 60 x 16 cm (length x width x height).
P1	CHEP pallet 60 cm x 80 cm Commonwealth Handling Equipment Pool (CHEP) standard pallet of dimensions 60 centimeters x 80 centimeters.
P2	Pan A shallow, wide, open container, usually of metal.
P3	LPR pallet 60 cm x 80 cm LPR (La Pallet Rouge) standard pallet of dimensions 60 cm x 80 cm.
P4	LPR pallet 80 cm x 120 cm LPR (La Pallet Rouge) standard pallet of dimensions 80 cm x 120 cm.
PA	Packet
PB	Pallet, box
PC	Parcel
PD	Pallet, modular, collars 80cms * 100cms
PE	Pallet, modular, collars 80cms * 120cms

Used Codes

PF	Pen
PG	Plate
PH	Pitcher
PI	Pipe
PJ	Punnet
PK	Package
PL	Pail
PN	Plank
PO	Pouch
PP	Piece A loose or unpacked article.
PR	Receptacle, plastic
PT	Pot
PU	Tray pack
PV	Pipes, in bundle/bunch/truss
PX	Pallet
PY	Plates, in bundle/bunch/truss
PZ	Planks, in bundle/bunch/truss
QA	Drum, steel, non-removable head
QB	Drum, steel, removable head
QC	Drum, aluminium, non-removable head
QD	Drum, aluminium, removable head
QF	Drum, plastic, non-removable head
QG	Drum, plastic, removable head
QH	Barrel, wooden, bung type
QJ	Barrel, wooden, removable head
QK	Jerrican, steel, non-removable head
QL	Jerrican, steel, removable head
QM	Jerrican, plastic, non-removable head
QN	Jerrican, plastic, removable head
QP	Box, wooden, natural wood, ordinary
QQ	Box, wooden, natural wood, with sift proof walls
QR	Box, plastic, expanded

Used Codes

QS	Box, plastic, solid
RD	Rod
RG	Ring
RJ	Rack, clothing hanger
RK	Rack
RL	Reel
RO	Roll
RT	Rednet
RZ	Rods, in bundle/bunch/truss
SA	Sack
SB	Slab
SC	Crate, shallow
SD	Spindle
SE	Sea-chest
SH	Sachet
SI	Skid
SK	Case, skeleton
SL	Slipsheet
SM	Sheetmetal
SO	Spool
SP	Sheet, plastic wrapping
SS	Case, steel
ST	Sheet
SU	Suitcase
SV	Envelope, steel
SW	Shrinkwrapped
SY	Sleeve
SZ	Sheets, in bundle/bunch/truss
T1	Tablet A loose or unpacked article in the form of a bar, block or piece.
TB	Tub
TC	Tea-chest
TD	Tube, collapsible

Used Codes

TE	Tyre A ring made of rubber and/or metal surrounding a wheel.
TG	Tank container, generic A specially constructed container for transporting liquids and gases in bulk.
TI	Tierce TI
TK	Tank, rectangular
TL	Tub, with lid
TN	Tin
TO	Tun
TR	Trunk
TS	Truss
TT	Bag, tote A capacious bag or basket.
TU	Tube
TV	Tube, with nozzle
TW	Pallet, triwall A lightweight pallet made from heavy duty corrugated board.
TY	Tank, cylindrical
TZ	Tubes, in bundle/bunch/truss
UC	Uncaged
UN	Unit A type of package composed of a single item or object, not otherwise specified as a unit of transport equipment.
VA	Vat
VG	Bulk, gas (at 1031 mbar and 15 degree C)
VI	Vial
VK	Vanpack
VL	Bulk, liquid
VN	Vehicle A self-propelled means of conveyance.
VO	Bulk, solid, large particles ("nodules")
VP	Vacuum-packed
VQ	Bulk, liquefied gas (at abnormal temperature/pressure)
VR	Bulk, solid, granular particles ("grains")

Used Codes

VS	Bulk, scrap metal Loose or unpacked scrap metal transported in bulk form.
VY	Bulk, solid, fine particles ("powders")
WA	Intermediate bulk container
WB	Wickerbottle
WC	Intermediate bulk container, steel
WD	Intermediate bulk container, aluminium
WF	Intermediate bulk container, metal
WG	Intermediate bulk container, steel, pressurised > 10 kpa
WH	Intermediate bulk container, aluminium, pressurised > 10 kpa
WJ	Intermediate bulk container, metal, pressure 10 kpa
WK	Intermediate bulk container, steel, liquid
WL	Intermediate bulk container, aluminium, liquid
WM	Intermediate bulk container, metal, liquid
WN	Intermediate bulk container, woven plastic, without coat/liner
WP	Intermediate bulk container, woven plastic, coated
WQ	Intermediate bulk container, woven plastic, with liner
WR	Intermediate bulk container, woven plastic, coated and liner
WS	Intermediate bulk container, plastic film
WT	Intermediate bulk container, textile with out coat/liner
WU	Intermediate bulk container, natural wood, with inner liner
WV	Intermediate bulk container, textile, coated
WW	Intermediate bulk container, textile, with liner
WX	Intermediate bulk container, textile, coated and liner
WY	Intermediate bulk container, plywood, with inner liner
WZ	Intermediate bulk container, reconstituted wood, with inner liner
XA	Bag, woven plastic, without inner coat/liner
XB	Bag, woven plastic, sift proof
XC	Bag, woven plastic, water resistant
XD	Bag, plastics film
XF	Bag, textile, without inner coat/liner
XG	Bag, textile, sift proof
XH	Bag, textile, water resistant

Used Codes

XJ	Bag, paper, multi-wall
XK	Bag, paper, multi-wall, water resistant
YA	Composite packaging, plastic receptacle in steel drum
YB	Composite packaging, plastic receptacle in steel crate box
YC	Composite packaging, plastic receptacle in aluminium drum
YD	Composite packaging, plastic receptacle in aluminium crate
YF	Composite packaging, plastic receptacle in wooden box
YG	Composite packaging, plastic receptacle in plywood drum
YH	Composite packaging, plastic receptacle in plywood box
YJ	Composite packaging, plastic receptacle in fibre drum
YK	Composite packaging, plastic receptacle in fibreboard box
YL	Composite packaging, plastic receptacle in plastic drum
YM	Composite packaging, plastic receptacle in solid plastic box
YN	Composite packaging, glass receptacle in steel drum
YP	Composite packaging, glass receptacle in steel crate box
YQ	Composite packaging, glass receptacle in aluminium drum
YR	Composite packaging, glass receptacle in aluminium crate
YS	Composite packaging, glass receptacle in wooden box
YT	Composite packaging, glass receptacle in plywood drum
YV	Composite packaging, glass receptacle in wickerwork hamper
YW	Composite packaging, glass receptacle in fibre drum
YX	Composite packaging, glass receptacle in fibreboard box
YY	Composite packaging, glass receptacle in expandable plastic pack
YZ	Composite packaging, glass receptacle in solid plastic pack
ZA	Intermediate bulk container, paper, multi-wall
ZB	Bag, large
ZC	Intermediate bulk container, paper, multi-wall, water resistant
ZD	Intermediate bulk container, rigid plastic, with structural equipment, solids
ZF	Intermediate bulk container, rigid plastic, freestanding, solids
ZG	Intermediate bulk container, rigid plastic, with structural equipment, pressurised
ZH	Intermediate bulk container, rigid plastic, freestanding, pressurised
ZJ	Intermediate bulk container, rigid plastic, with structural equipment, liquids
ZK	Intermediate bulk container, rigid plastic, freestanding, liquids

Used Codes

ZL	Intermediate bulk container, composite, rigid plastic, solids
ZM	Intermediate bulk container, composite, flexible plastic, solids
ZN	Intermediate bulk container, composite, rigid plastic, pressurised
ZP	Intermediate bulk container, composite, flexible plastic, pressurised
ZQ	Intermediate bulk container, composite, rigid plastic, liquids
ZR	Intermediate bulk container, composite, flexible plastic, liquids
ZS	Intermediate bulk container, composite
ZT	Intermediate bulk container, fibreboard
ZU	Intermediate bulk container, flexible
ZV	Intermediate bulk container, metal, other than steel
ZW	Intermediate bulk container, natural wood
ZX	Intermediate bulk container, plywood
ZY	Intermediate bulk container, reconstituted wood
ZZ	Mutually defined
08	Oneway pallet (GS1 Temporary Code) Pallet need not be returned to the point of expedition.
09	Returnable pallet (GS1 Temporary Code) Pallet must be returned to the point of expedition.
200	Pallet ISO 0 - 1/2 EURO Pallet (GS1 Temporary Code) Standard pallet with dimensions 80 X 60 cm.
201	Pallet ISO 1 - 1/1 EURO Pallet (GS1 Temporary Code) Standard pallet with dimensions 80 X 120 cm.
202	Pallet ISO 2 (GS1 Temporary Code) Standard pallet with dimensions 100 X 120 cm.
203	1/4 EURO Pallet (GS1 Temporary Code) Standard pallet with dimensions 60 X 40 cm.
204	1/8 EURO Pallet (GS1 Temporary Code) Standard pallet with dimensions 40 X 30 cm.
205	Synthetic pallet ISO 1 (GS1 Temporary Code) A standard pallet with standard dimensions 80*120cm made of a synthetic material for hygienic reasons.
206	Synthetic pallet ISO 2 (GS1 Temporary Code) A standard pallet with standard dimensions 100*120cm made of a synthetic material for hygienic reasons.
210	Wholesaler pallet (GS1 Temporary Code) Pallet provided by the wholesaler.

Used Codes

211	Pallet 80 X 100 cm (GS1 Temporary Code) Pallet with dimensions 80 X 100 cm.
212	Pallet 60 X 100 cm (GS1 Temporary Code) Pallet with dimensions 60 X 100 cm.
AH	Pallet 100cms * 110cms Standard sized pallet of dimensions 100centimeters by 110 centimeters (cms). EDIFACT
AI	Clamshell EDIFACT
APE	Aluminium packed (GS1 Temporary Code) Packaging using thin sheets of aluminium.
BGE	Large bag, pallet sized (GS1 Temporary Code) A non-rigid container made of fabric, paper, plastic, etc, with an opening at the top which can be closed and which is suitable for use on pallets.
BME	Blister pack (GS1 Temporary Code) A transparent strip package of pressable plastic which allows the product to be displayed while remaining protected.
BRI	Brick (GS1 Temporary Code) A box made of a cardboard, plastic or metal, used for liquids.
CBL	Container bottle like (GS1 Temporary Code) A non-protected, non-cylindrical, container with a narrow neck made usually of glass or plastic which is especially used for liquids, e.g. perfume bottle.
CCE	Cardboard carrier (GS1 Temporary Code) A package made of cardboard.
CM	Card A flat package usually made of fibreboard from/to which the product is often hung or attached. EDIFACT
E1	Performance meat container E1 (GS1 Temporary Code) Standard performance meat container with dimensions 60 X 40 X 12,5 cm.
E2	Performance meat container E2 (GS1 Temporary Code) Standard performance meat container with dimensions 60 X 40 X 20 cm.
E3	Performance meat container E3 (GS1 Temporary Code) Standard performance meat container with dimensions 60 X 40 X 30 cm.
FOB	Folding box (GS1 Temporary Code) Folded cardboard box e.g for products like frozen vegetables, paper clips
FPE	Foil packed (GS1 Temporary Code) Packaging using a metallic foil.

Used Codes

LAB	Labeled package (GS1 Temporary Code) The package is labeled. Usually the label identifies the name, brand or description of the product within the package.
MPE	Multipack (GS1 Temporary Code) A container for the merchandising of multiple units of the same product.
OPE	Oxygen packed (GS1 Temporary Code) A package with oxygen added for storage purposes.
PAE	Paper (GS1 Temporary Code) An indication that the item(s) is packed in paper.
PJ	Punnet EDIFACT
PLP	Peel pack (GS1 Temporary Code) A package used for sterile products which may be torn open without touching the product inside.
POP	Cone shaped paper wrapper (GS1 Temporary Code) Cone shaped paper wrapping e.g. for an individually packed ice cream cone.
PPE	Polypropylene bag (GS1 Temporary Code) A bag made from polypropylene.
PUE	Tray packed in plastic (GS1 Temporary Code) A board with a ring packed in plastic carrying for small articles.
RB3	Wheeled pallet with raised rim. 81 x 60 x 16 cm (length x width x height). (GS1 Temporary Code) A wheeled pallet with raised rim for the storing and transporting of loads. Dimensions: 81 x 60 x 16 cm (length x width x height).
RCB	Two sided cage on wheels with fixing strap (GS1 Temporary Code) 900 x 770 x 1513 cm (length x width x height) A two sided cage mounted on wheels with fixing strap. Dimensions: 900 x 770 x 1513 cm (length x width x height).
S1	GS1 SMART-Box Type E (GS1 Temporary Code) Standard reusable crate with dimensions 60 x 40 x 21,1 cm.
SEC	Article Surveillance (GS1 Temporary Code) Equipped with article surveillance.
SO	Spool Any cylindrical piece on which something is wound.
SP	Sheet, plastic wrapping EDIFACT
STL	Stick (GS1 Temporary Code) A container for dispensing solid substances, e.g. glue, deodorant.

Used Codes

T1	Tablet A loose or unpacked article in the form of a bar, block or piece. EDIFACT
TEV	Tamper evident package (GS1 Temporary Code) A type of package giving easy or immediate recognition that the package has been tampered with after it has been sealed.
THE	Three pack (GS1 Temporary Code) A package containing three products.
TL	Tub, with lid EDIFACT
TRE	Trolley (GS1 Temporary Code) A low cart for the transportation and storage of groceries, milk, etc.
TTE	Tube, standing (GS1 Temporary Code) A screw-topped pliable cylinder capable of standing and suitable for holding pastes or semi-liquids, e.g. a tube of toothpaste.
TWE	Two pack (GS1 Temporary Code) A package containing two products.
UUE	Tube net (GS1 Temporary Code) A plastic or textile tube suitable for carrying loose products, e.g. fruit.
UVQ	Wrapped in plastic sheet (GS1 Temporary Code) An indication that the items have been wrapped in plastic sheet.
WRP	Wrapper (GS1 Temporary Code) Wrapping e.g. for an individually packed ice cream.
X11	Banded package (GS1 Temporary Code) A package with bands, usually metal or nylon, round it to hold the products together.
X15	Oneway pallet ISO 0 - 1/2 EURO Pallet (GS1 Temporary Code) Oneway pallet with dimensions 80 X 60 cm.
X16	Oneway pallet ISO 1 - 1/1 EURO Pallet (GS1 Temporary Code) Oneway pallet with dimensions 80 X 120 cm.
X17	Non-standard pallet (GS1 Temporary Code) Non-Standard pallet
X18	Parcel with exceptional dimensions (GS1 Temporary Code) Parcel with non-standard dimensions.
X3	Standard stack of stones (GS1 Temporary Code) Standard stack of stones.
7073	Packaging terms and conditions code Code specifying the packaging terms and conditions.

Used Codes

1	Packaging cost paid by supplier The cost of packaging is paid by the supplier.
2	Packaging cost paid by recipient The cost of packaging is paid by the recipient.
3	Packaging cost not charged (returnable) There is no charge for packaging because it is returnable.
24	Rented The package has been, or will be, rented. EDIFACT
25	Safe return deposit A deposit paid to guarantee the safe return of the package.
26	Not reusable The package is not reusable. GS1 Description: The equipment may only be used once and is not reusable for the purpose for which it was designed.
27	Package exchangeable at the point of delivery The package may be exchanged at the point of delivery.
29	Labeled The package is labeled. EDIFACT
1E	Unpack from (GS1 Temporary Code) Code identifying that goods should be unpacked from the identified package.
2E	Repack in (GS1 Temporary Code) Code identifying that goods should be repacked from the identified package.
3E	Pack in (GS1 Temporary Code) Code identifying that goods should be packed from the identified package.
X11	Packaging recycling fee paid by supplier (GS1 Temporary Code) The fee for recycling packaging is paid by the supplier.
XX1	Exchange Pallets (GS1 Temporary Code) The pallet is exchanged.
XX2	Return Pallets (GS1 Temporary Code) The pallet is returned.
XX3	Pallet - Third Party Exchange (GS1 Temporary Code) The pallet is exchanged by a third party.
XX4	No Exchange / No Return Pallet (GS1 Temporary Code) No pallet exchange or return.

Used Codes

7075	Packaging level code Code specifying a level of packaging.
1	Inner Level of packing, if it exists, that is immediately subordinate to the intermediate packaging level.
2	Intermediate Level of packaging, if it exists, that is immediately subordinate to the outer packaging level.
3	Outer For packed merchandise, outermost level of packaging for a shipment.
4	No packaging hierarchy There is no specifiable level of packaging: packaging is inner and outer level as well.
5	Shipment Level The packaging level described is the shipment level.
1E	Highest (GS1 Temporary Code) Level of packaging, if it exists, which is highest in the packaging hierarchy.
7077	Description format code Code specifying the format of a description.
A	Free-form long description Long description of an item in free form.
B	Code and text Description of an item in coded and free form text.
C	Code (from industry code list) Description of an item in coded format. GS1 Description: Description of an item provided in coded format from an industry list.
D	Free-form price look up Price look-up description of a product for point of sale receipts.
E	Free-form short description Short description of an item in free form.
F	Free-form Description of an item in free form text. GS1 Description: Item related general free form text description, which is neither a short or long description of the item itself.
S	Structured (from industry code list) Description of an item in a structured format.

Used Codes

7081	Item characteristic code Code specifying the characteristic of an item.
2	General product form Description of general product form.
3	Ship to stock Product without quality control when received.
4	Finish Description of the finish required/available on the product.
6	Construction method Description of the method of construction.
13	Quality The degree of excellence of a thing. GS1 Description: Characteristics to be described refer to the quality of the item.
27	Material description Description of material used to manufacture a product. GS1 Description: Free text description of the materials of which the article is composed.
31	European Community risk class European community classification "CE" indicating the safety risk of an article. GS1 Description: European commission classification indicating the safety risk of an article (also called CE-mark or CE-risk class).
35	Colour Description of the colour required/available on the product.
38	Grade Specification of the grade required/available for the product. GS1 Description: Specification of the grade required/available for the product, e.g. the grade of fruit.
44	Further identifying characteristic Description of further identifying characteristic of a product which enables the product to be distinguished from any similar products. GS1 Description: Extra descriptive information in free text which makes it possible to distinguish almost, but not completely, similar articles.
45	Private label name Describes the private label name of a product.
46	Silhouette Describes the outline of the item.

Used Codes

47	Warranty type description The warranty type description of the item.
48	Yarn count Describes the fineness of the yarn in the cloth. GS1 Note: Replaces GS1 Temporary Code U07. EDIFACT
61	New article The characteristic of a new item or commodity.
72	Vintage The harvest year of the grapes that are part of the composition of a particular wine.
75	Artist The performing artist(es) of a recorded song or piece of music.
76	Author The author of a written work.
77	Binding A description of the type of binding used for a written work.
78	Edition Description of the edition of a written work.
79	Other physical description Any other relevant physical description.
80	Publisher The publisher of a written piece of work as part of the item description.
81	Title The title of a work.
82	Series title Title of a series of works.
83	Volume title The title of a volume of work.
84	Composer The composer of a recorded song or piece of music.
85	Recording medium The medium on which a musical recording is made.
86	Music style The style of music.
87	Promotional event Describes the promotional event associated with a product.

Used Codes

98	Size Description of size in non-numeric terms.
120	Chemistry Code indicating the product's chemical characteristics.
126	Pattern Code indicating the product's pattern characteristics.
132	Fabric Code indicating the product's fabric characteristics.
169	Market segment Code indicating the market segment associated with a product.
171	Physical form Code indicating the physical form of a product.
196	Additional sectorial characteristics A code issued on a sectorial basis which identifies any additional characteristics of a product.
197	Product data base management description A description indicating how a product should be managed in a data base.
219	Style A kind, sort, or type that distinguishes one commodity from another commodity with similar characteristics. GS1 Note: Replaces GS1 Temporary Code STE. EDIFACT
223	Brand name The brand name of an item. EDIFACT
ANM	Article name (GS1 Temporary Code) The name of the product.
AVI	Available for ordering (GS1 Temporary Code) Goods are available for ordering.
BPD	Publication date (GS1 Temporary Code) The publication date of a written work as an element of the description.
BVP	Volume or part number (GS1 Temporary Code) The volume or part number of a written work.
DSC	Description (GS1 Temporary Code) A non-structured description of a product.
ECO	ECO labelling description (GS1 Temporary Code) Description of ECO labelling.

Used Codes

EDS	Expiry date surpassed (GS1 Temporary Code) The expiry date for goods has been surpassed.
FGT	Fishing gear type (GS1 Permanent Code) Fishing gear type
FN	Functional Name (GS1 Temporary Code) Describes use of the product or service by the consumer. Should help clarify the product classification associated with the GTIN.
FPC	Fish presentation code (GS1 Permanent Code) Fish presentation code
FQG	Fish quality grade (GS1 Permanent Code) Fish quality grade
FRZ	Freezing information (GS1 Permanent Code) Freezing information
FSS	Fish standardized size (GS1 Permanent Code) Fish standardized size
GDC	GIFAM fault code (GS1 Temporary Code) A code used in the white goods industry to identify faults.
GEO	Geographical area (GS1 Permanent Code) Relevant geographical area.
HAN	Handling instructions (GS1 Temporary Code) A code identifying a coded description of handling instructions.
HAZ	Hazardous material codes (GS1 Temporary Code) A code identifying a coded description of hazardous materials.
IDC	IRIS fault code (GS1 Temporary Code) A code used in the brown goods industry to identify faults.
IN	Invoice name (GS1 Temporary Code) Free form information provider assigned trade item description designed to match trade item/service description as noted on invoices.
IRC	IRIS repair code (GS1 Temporary Code) A code used in the brown goods industry to identify a repair required to correct a fault.
ISC	IRIS section code (GS1 Temporary Code) A code used in the brown goods industry to identify a section containing a fault.
ISY	IRIS symptom code (GS1 Temporary Code) A code used in the brown goods industry to identify a symptom of a fault.

Used Codes

KEY	<p>Keyword (GS1 Temporary Code)</p> <p>A word which may used as a search key to select items from a product file. A keyword is usually a word which does not exist in the product description but may exist in information accompanying the product, e.g. Keyword = Absorbent, Product description = Gauze dressing, Product information = 1 Peelpack with 10 absorbent gauze dressings.</p>
MNF	<p>Manufacturer (GS1 Temporary Code)</p> <p>The name of the manufacturer of the product which is printed on the product packaging.</p>
NAV	<p>Not available for ordering (GS1 Temporary Code)</p> <p>Goods are not available for ordering.</p>
OFS	<p>Order Fulfilment Strategy (GS1 Temporary Code)</p> <p>The method used by the supplier to fulfil a customer order for a particular product. Three strategies are recognised: Make to Order, Make to Stock and Engineer to Order.</p>
PR	<p>Product Range (GS1 Temporary Code)</p> <p>A name, used by a BrandOwner, that span multiple consumer categories or uses. E.g. (Waist Watchers).</p>
PRO	<p>Production Method (GS1 Permanent Code)</p> <p>Production Method Characteristics.</p>
RLI	<p>Rolling instructions (GS1 Temporary Code)</p> <p>Instructions concerning the rolling of material, e.g. paper, plastic, carpet, etc.</p>
SB	<p>Subbrand (GS1 Temporary Code)</p> <p>Second level of brand. Can be a trademark. It is the primary differentiating factor that a brand owner wants to communicate to the consumer or buyer.</p>
SBN	<p>Primary differentiating factor that a brand owner wants to communicate (GS1 Temporary Code)</p> <p>Second level of brand. Can be a trademark. It is the primary differentiating factor that a brand owner wants to communicate to the consumer or buyer. E.g. Yummy-Cola Classic. In this example Yummy-Cola is the brand and Classic is the subBrand.</p>
SCT	<p>Scientific name (GS1 Permanent Code)</p> <p>The scientific name of a product.</p>
SDS	<p>Shelf description (GS1 Temporary Code)</p> <p>A description of the product for shelf edge labelling purposes.</p>
SGR	<p>Size grid (GS1 Temporary Code)</p> <p>Grid of sizes, containing for a certain type of size (e.g., womans, France, etc) each possible value of the size (e.g., 28, 30, 32, etc).</p>
STE	<p>Style (GS1 Temporary Code)</p> <p>A code identifying the style of a product.</p> <p>GS1 Note: Code marked for deletion. Use value 219 instead.</p>

Used Codes

TDS	Technical description (GS1 Temporary Code) The technical description of a product.
TPE	Article type (GS1 Temporary Code) The article type allocated by the manufacturer to a product.
U02	Fiber (GS1 Temporary Code) A code identifying the fiber contained in a cloth.
U07	Yarn content (GS1 Temporary Code) A code indicating the yarn content of a fabric. GS1 Note: Code marked for deletion. Use value 48 instead.
U08	Roll pattern out (GS1 Temporary Code) An instruction to roll the product with the pattern side facing out.
U09	Roll pattern in (GS1 Temporary Code) An instruction to roll the product with the pattern side facing in.
UP2	Packaging language (GS1 Temporary Code) Language used for package markings.
UP4	Promotional free goods (GS1 Temporary Code) Free goods not associated to any other product given for promotional reasons.
UP5	Width or fitting (GS1 Temporary Code) An indication of the width or fitting (e.g. wide, loose, etc.) of a shoe or textile product.
UP6	Material shoe upper (GS1 Temporary Code) An indication of the material (e.g. leather, suede, canvas, etc.) used to construct a shoe upper.
UP7	Material shoe sole (GS1 Temporary Code) An indication of the material (e.g. leather, rubber, etc.) used to construct the sole of a shoe.
UP8	Material lining (GS1 Temporary Code) An indication of the lining (e.g. silk, leather, etc.) of a shoe or textile product.
UP9	Shoe heel height (GS1 Temporary Code) An indication of the height of the heel of a shoe.
UQ1	Base article exception rule (GS1 Temporary Code) An indication that what follows is a base article exception rule.
UQ2	Orchestra (GS1 Temporary Code) The Orchestra of a recorded song or piece of music.
UQ3	Conductor (GS1 Temporary Code) The conductor of a recorded song or piece of music.

Used Codes

UQ5	Inspection agencies (GS1 Temporary Code) Characteristics to be described refer to inspection agencies controlling the item described.
UQ6	Product without theft protection (GS1 Temporary Code) The product is not fitted with a protection against theft.
UQ7	Product with theft protection, active (GS1 Temporary Code) The product is fitted with a protection against theft that has been activated.
UQ8	Product with theft protection, inactive (GS1 Temporary Code) The product is fitted with a protection against theft that has not been activated.
WVL	Weight or volume loss (GS1 Temporary Code) Goods have suffered a weight or volume loss.
XX1	Collar Type (GS1 Temporary Code) Type of collar on the garment.
XX2	Sleeve Type (GS1 Temporary Code) Type of sleeve on the garment.
XX3	Clothing Cut (GS1 Temporary Code) Code identifying the clothing cut.
XX4	Non marked trade item components (GS1 Temporary Code) Code identifying the of price by measure.
XX5	Campaign name (GS1 Temporary Code) The type of a variable measure trade item.
XX6	Season name (GS1 Temporary Code) Element defines the season applicable to the item.
XX7	Season parameter (GS1 Temporary Code) Indication of the season, in which the trade item is available, i.e. assignment to one of the following collection periods: spring/summer, autumn/ winter or all year around.
XX8	Target Consumer Age (GS1 Temporary Code) Identifies the target consumer age range for which a trade item has been designed.
XX9	Target Consumer Gender (GS1 Temporary Code) Identifies the target consumer gender for which a product has been designed.
XY1	Link to external description (GS1 Temporary Code) The link (e.g. URL) to the external description.
XY2	Additional Trade Item Description (GS1 Temporary Code) Additional variants necessary to communicate to the industry to help define the product. Multiple variants can be established for each GTIN. This is a repeatable field, e.g. Style, Color, and Fragrance.

Used Codes

XY3	Trade item group identification (GS1 Temporary Code) The text description of the value represented by the trade itemGroupIDCode.
XY4	Price by measure type (GS1 Temporary Code) Code identifying the of price by measure.
XY5	Variable trade item type (GS1 Temporary Code) The type of a variable measure trade item.
7143	Item type identification code Coded identification of an item type.
AA	Product version number Number assigned by manufacturer or seller to identify the release of a product.
AC	HIBC (Health Industry Bar Code) Article identifier used within health sector to indicate data used conforms to HIBC.
AQ	Coupon number GS1 Description: A number identifying a coupon which is attached to the identified product.
AT	Price look up number Identification number on a product allowing a quick electronic retrieval of price information for that product.
ATC	Therapeutic classification number (GS1 Temporary Code) A code to specify a product's therapeutic classification.
BAN	Base article node number (GS1 Temporary Code) A number which identifies a node within a base article configuration.
BB	Lot number A number indicating the lot number of a product.
BP	Buyer's part number Reference number assigned by the buyer to identify an article. GS1 Description: Reference number assigned by the buyer to identify an article. GS1 usage note: As the code values 'BP' and 'IN' are defined in the same way, it is recommended that the code value 'IN' be used to specify any article numbers assigned by the buyer.
BRI	Brick Code (GS1 Temporary Code) Global GS1 classification category code. Unique, permanent 10-digit key.
BU	Dye lot number Number identifying a dye lot.
BZ	Original equipment number Original equipment number allocated to spare parts by the manufacturer.

Used Codes

CG	Commodity grouping Code for a group of articles with common characteristics (e.g. used for statistical purposes).
DW	Drawing Reference number identifying a drawing of an article.
ECP	ECLASS property (GS1 Temporary Code) Unique code which identifies the ECLASS classification property.
ECV	ECLASS property value (GS1 Temporary Code) Value for a property according to the ECLASS classification.
EWC	European Waste Catalogue (GS1 Temporary Code) Waste type number according to the European Waste Catalogue (EWC).
FS	Fish species Identification of fish species.
GAT	GPC Brick attribute type (GS1 Temporary Code) Unique 8 digit code which identifies the Global GS1 classification.
GAV	GPC brick attribute value (GS1 Temporary Code) Unique 8 digit code which identifies the Global GS1 classification attribute value
GB	Buyer's internal product group code Product group code used within a buyer's internal systems.
GD	Industry sector article group number/product classification code (GS1 Temporary Code) Sectoral product group or classification identification code. Administered by a sector specific agency.
GLN	Global Location Number (GS1 Temporary Code) Unique location number assigned by a Member Organisation of GS1.
GMN	Global Model Number The GMN is the GS1-identification key used to identify a product model or product family based on attributes common to the model or family as defined by industry or regulation.
GN	National product group code National product group code. Administered by a national agency.
GU	Supplier's internal article group number/product classification code (GS1 Temporary Code) Product group or classification identification code within a supplier's internal system.
HS	Harmonised system The item number is part of, or is generated in the context of the Harmonised Commodity Description and Coding System (Harmonised System), as developed and maintained by the World Customs Organization (WCO).

Used Codes

IB	ISBN (International Standard Book Number) Self explanatory.
IN	Buyer's item number The item number has been allocated by the buyer.
IS	ISSN (International Standard Serial Number) Self explanatory.
IT	Buyer's style number Number given by the buyer to a specific style or form of an article, especially used for garments.
LI	Line item number (GS1 Temporary Code) Number identifying a specific line within a document/message.
MF	Manufacturer's (producer's) article number The number given to an article by its manufacturer.
MN	Model number Reference number assigned by the manufacturer to differentiate variations in similar products in a class or group.
NB	Batch number The item number is a batch number. GS1 Description: Number supplementing the identification code of a product used to identify the specific production place and/or time of a product.
PGC	Price grouping code (GS1 Temporary Code) Number assigned to identify a grouping of products based on price.
PV	Promotional variant number The item number is a promotional variant number. GS1 Description: Number supplementing the identification code of a product and identifying that product as a variant of the standard product. To be used when the variation is not sufficiently significant to justify a change fo the main identification code of the product.
RVM	Restricted circulation variable measure number (GS1 Temporary Code) A number assigned to identify a restricted circulation variable measure item.
SA	Supplier's article number Number assigned to an article by the supplier of that article.
SN	Serial number Identification number of an item which distinguishes this specific item out of a number of identical items.

Used Codes

SPP	Standard product also used in promotions (GS1 Temporary Code) Article number of a standard product which may temporarily also be used for promotional purposes, e.g. the physical product or price of the product does not change but a christmas tree is marked on the packaging to decorate the product for christmas.
SRS	RSK number Plumbing and heating.
SRT	IFLS (Institut Francais du Libre Service) 5 digit product classification code 5 digit code for product classification managed by the Institut Francais du Libre Service.
SRU	IFLS (Institut Francais du Libre Service) 9 digit product classification code 9 digit code for product classification managed by the Institut Francais du Libre Service.
SRV	GS1 Global Trade Item Number A unique number, up to 14-digits, assigned according to the numbering structure of the GS1 system. 'GS1' stands for the 'Global Standards One'.
SRX	Slaughter number Unique number given by a slaughterhouse to an animal or a group of animals of the same breed. EDIFACT
SSS	Distributor's article identifier Identifier assigned to an article by the distributor of that article.
SST	Norwegian Classification system ENVA Product classification system used in the Norwegian market. EDIFACT
SSU	Supplier assigned Product classification assigned by the supplier. EDIFACT
SSV	Mexican classification system AMECE Product classification system used in the Mexican market. EDIFACT
SSW	German classification system CCG Product classification system used in the German market. EDIFACT
SSX	Finnish classification system EANFIN Product classification system used in the Finnish market. EDIFACT
SSY	Canadian classification system ICC Product classification system used in the Canadian market. EDIFACT

Used Codes

SSZ	Dutch classification system CBL Product classification system used in the Dutch market. EDIFACT
ST	Style number Number given to a specific style or form of an article, especially used for garments.
STA	Dutch classification system CBL Product classification system used in the Dutch market.
STB	Japanese classification system JICFS Product Classification system used in the Japanese market.
STC	European Union dairy subsidy eligibility classification Category of product eligible for EU subsidy (applies for certain dairy products with specific level of fat content).
STD	GS1 Spain Classification Product classification system used in the Spanish Market.
STE	GS1 Poland classification system Product classification system used in the Polish market.
STF	Federal Agency on Technical Regulating and Metrology of the Russian Federation A Russian government agency that serves as a national standardization body of the Russian Federation.
STG	Efficient Consumer Response (ECR) Austria classification system Product classification system used in the Austrian market.
STH	GS1 Italy classification system Product classification system used in the Italian market
STI	CPV (Common Procurement Vocabulary) Official classification system for public procurement in the European Union.
STJ	IFDA (International Foodservice Distributors Association) International Foodservice Distributors Association (IFDA).
STK	AHFS (American Hospital Formulary Service) pharmacologic therapeutic classification. Pharmacologic therapeutic classification maintained by the American Hospital Formulary Service (AHFS).
STL	ATC (Anatomical Therapeutic Chemical) classification system Anatomical Therapeutic Chemical classification system maintained by the World Health Organisation (WHO).
STM	CLADIMED (Classification des Dispositifs Médicaux) A five level classification system for medical devices maintained by the CLADIMED organisation used in the French market.

Used Codes

STN	CMDR (Canadian Medical Device Regulations) classification system Classification system related to the Canadian Medical Device Regulations maintained by Health Canada.
STO	CNDM (Classificazione Nazionale dei Dispositivi Medici) A classification system for medical devices used in the Italian market.
STP	UK DM&D (Dictionary of Medicines & Devices) standard coding scheme A classification system for medicines and devices use in the UK market.
STQ	ECLASS Standardized material and service classification and dictionary maintained by ECLASS e.V.
STR	EDMA (European Diagnostic Manufacturers Association) Products Classification Classification for in vitro diagnostics medical devices maintained by the European Diagnostic Manufacturers Association.
STS	EGAR (European Generic Article Register) A classification system for medical devices.
STT	GMDN (Global Medical Devices Nomenclature) Nomenclature system for identification of medical devices officially approved by the European Union.
STU	GPI (Generic Product Identifier) A drug classification system managed by Medi-Span.
STV	HCPCS (Healthcare Common Procedure Coding System) A classification system used with US healthcar insurance programs.
STW	ICPS (International Classification for Patient Safety) A patient safety taxonomy maintained by the World Health Organisation.
STX	MedDRA (Medical Dictionary for Regulatory Activities) A medical dictionary maintained by the International Federation of Pharmaceutical Manufacturers and Associations (IFPMA).
STY	Medical Columbus Medical product classification system used in the German market.
STZ	NAPCS (North American Product Classification System) Product classification system used in the North American market.
SUA	NHS (National Health Services) eClass Product and Service classification system used in United Kingdom market.
SUB	US FDA (Food and Drug Administration) Product Code Classification Database US FDA Product Code Classification Database contains medical device names and associated information developed by the Center for Devices and Radiological Health (CDRH).

Used Codes

SUC	SNOMED CT (Systematized Nomenclature of Medicine-Clinical Terms) A medical nomenclature system developed between the NHS and the College of American Pathologists.
SUD	UMDNS (Universal Medical Device Nomenclature System) A standard international nomenclature and computer coding system for medical devices maintained by the Emergency Care Research Institute (ECRI).
SUE	GS1 Global Returnable Asset Identifier, non-serialised A unique, 13-digit number assigned according to the numbering structure of the GS1 system and used to identify a type of Reusable Transport Item (RTI).
SUF	IMEI The International Mobile Station Equipment Identity (IMEI) is a unique number to identify mobile phones. It includes the origin, model and serial number of the device. The structure is specified in 3GPP TS 23.003.
UA	Ultimate customer's article number Number assigned by ultimate customer to identify relevant article.
X10	Lottery game number (GS1 Temporary Code) The number of a lottery game.
X11	Lottery pack book number (GS1 Temporary Code) The number of a lottery pack book.
X12	NABCA product code (GS1 Temporary Code) NABCA code identifying alcoholic beverage brands and sizes.
X13	Waste type number (GS1 Temporary Code) Identification of the type of item number. Notes: User or association defined code. May be used in combination with 1131/3055.
X2	Ear-tag number (GS1 Temporary Code) Unique number given by a national authority to identify an animal individually.
7161	Special service description code Code specifying a special service.
0	Released (GS1 Temporary Code) Informs the stockholder it is free to distribute the quality controlled passed goods.
1	Quality control held (GS1 Temporary Code) Instructs the stockholder to withhold distribution of the goods until the manufacturer has completed a quality control assessment.
2	Quality controlled embargo (GS1 Temporary Code) Instructs the stockholder to withhold distribution of goods which have failed quality control tests.

Used Codes

AA	Advertising allowance Description to be provided. GS1 Description: Allowance for the advertising costs or activities related to the product.
AAB	Returned goods charges Self-explanatory. GS1 Description: Charges related to the return of goods.
AAJ	Copper surcharge Difference between current price and basic copper value contained in product price.
AAM	Rubber surcharge Difference between current price and basic value contained in product price.
AAT	Rush delivery Charge for increased delivery speed.
AAX	Wolfram surcharge Difference between current price and basic value contained in product price.
AAY	Airport fee Charge associated with usage of airport facilities.
ABA	Compulsory storage fee Fee levied to cover the cost of carrying a certain amount of compulsory inventory (set by regulatory agency).
ABH	Throughput allowance Allowance for reaching or exceeding an agreed throughput threshold.
ABL	Packaging surcharge Additional charge for packaging of items.
ABZ	Miscellaneous rebate or discount Non-defined rebate or discount.
ACQ	Royalty surcharge Additional charge on an item's price for royalty.
ACY	Container deposit charge The charge relating to the packaging of a product in a container when the container is expected to be returned and has value when empty.
ACZ	Damaged merchandise The charge or credit relating to the circumstance of product being damaged and not saleable.
ADM	Binding services A code indicating binding services.

Used Codes

ADN	Repair or replacement of broken returnable package The repair or replacement of a broken returnable package.
ADO	Efficient logistics A code indicating efficient logistics services.
ADP	Merchandising A code indicating that merchandising services are in operation.
ADQ	Product mix A code indicating that product mixing services are in operation.
ADR	Other services A code indicating that other non-specific services are in operation.
ADS	Full pallet ordering Ordering of a full pallet of a product.
ADT	Pick-up For the pick-up or collection of goods.
ADZ	Direct delivery The specification of direct delivery as a special service.
AEK	Cash on delivery service An allowance or charge related to the provision of a cash on delivery service.
AEM	Clerical or administrative services The provision of clerical or administrative services.
AEN	Guarantee service The provision of a guarantee service.
AEO	Collection and recycling service The service of collection and recycling products.
AEP	Copyright fee collection services The service of the collection of copyright fees.
AEQ	Charge for exceeding agreed ordered quantity Charge applicable if the ordered quantity exceeds the quantity that has been agreed upon. GS1 Description: Charge when what the buyer is ordering exceeds the quantity that has been agreed upon.
AES	Veterinary inspection service Allowance or charge related to the service of veterinary inspection.

Used Codes

AEV	<p>Environmental protection service An allowance or charge related to a provision of an environmental protection service. GS1 Description: An allowance or charge related to the provision of environmental protection or clean-up services.</p>
AEX	<p>National cheque processing service outside account area Service of processing a national cheque outside the ordering customer's bank trading area. GS1 Description: Service of processing a domestic cheque in an area, outside that where the ordering customer is holding his account.</p>
AEY	<p>National payment service outside account area Service of processing a national payment to a beneficiary holding an account outside the trading area of the ordering customer's bank.</p>
AEZ	<p>National payment service within account area Service of processing a national payment to a beneficiary holding an account within the trading area of the ordering customer's bank.</p>
AG	<p>Silver surcharge Difference between current price and basic value contained in product price.</p>
AJ	<p>Adjustments Description to be provided. GS1 Description: Allowance or charge related to adjustments.</p>
ASS	<p>Assortment allowance (GS1 Temporary Code) Allowance given when a specific part of a suppliers assortment is purchased by the buyer.</p>
CA	<p>Cataloguing services Description to be provided. GS1 Description: Allowance or charge related to the provision of cataloguing services.</p>
CAC	<p>Cash discount Discount incurring with cash payment.</p>
CAG	<p>Competitive allowance Price adjustment allowed for market conditions or factors.</p>
CAI	<p>Cutting charge Description to be provided. GS1 Description: An allowance or charge related to the service of cutting.</p>
CAL	<p>Payroll payment service Provision of a payroll payment service.</p>

Used Codes

CAM	Cash transportation service Provision of a cash transportation service.
CAN	Home banking service Provision of a home banking service.
CAP	Insurance brokerage service Provision of an insurance brokerage service. GS1 Description: Charge or allowance paid to a bank, related to the purchase of insurance using the bank as a broker.
CAQ	Cheque generation service Provision of a cheque generation service. GS1 Description: Charge paid to a bank which relates to the generation of a cheque.
CAR	Preferential merchandising location Service of assigning a preferential location for merchandising.
CAS	Crane service Provision of a crane service.
CAT	Special colour service Providing a colour which is different from the default colour.
CAU	Sorting The provision of sorting services. EDIFACT
CAV	Battery collection and recycling The service of collection and recycling batteries.
CAW	Product Take Back Fee The fee the consumer must pay the manufacturer to take back the product.
CP	Competitive price Description to be provided. GS1 Description: Allowance or charge related to the availability of a competitive price.
DAE	Distributor discount/allowance Specific discount/allowance for distributors.
DBD	Debtor bound (GS1 Temporary Code) A special allowance or charge applicable to a specific debtor.
DDA	Dealer discount/allowance (GS1 Temporary Code) A discount or allowance offered by a party dealing a certain brand or brands of products.

Used Codes

DI	Discount A reduction from a usual or list price. GS1 Description: A discount is a reduction in the price of an item offered on a one off basis. An important distinction to make between discount and an allowance offered is that an allowance is a reduction which is offered on a regular basis.
DTC	Discount transferable to the consumer (GS1 Temporary Code) A discount given by the manufacturer which should be transferred to the consumer.
EAA	Early buy allowance Allowance granted to customers buying early.
EAB	Early payment allowance Allowance granted to customers paying early.
FA	Freight allowance Description to be provided. GS1 Description: Allowance for the shipment of goods or commodity.
FC	Freight charge Amount to be paid for moving goods, by whatever means, from one place to another, inclusive discounts, allowances, rebates, adjustment factors and additional cost relating to freight costs (UN/ECE Recommendation no 23).
FG	Free goods Allowance or rebate granted by delivery of goods free of charge.
FI	Finance charge Description to be provided. GS1 Description: A charge related to the provision of financing.
FR	Flat Rate (GS1 Temporary Code) A flat rate is applied.
GRB	Growth of business (GS1 Temporary Code) An allowance or charge related to the growth of business over a pre-determined period of time.
HD	Handling Charge for handling of the item.
IN	Insurance Charge for insurance.
INT	Introduction allowance (GS1 Temporary Code) An allowance related to the introduction of a new product to the range of products traded by a retailer.

Used Codes

IS	Invoice services Description to be provided. GS1 Description: An allowance or charge related to the provision of invoicing services.
LA	Labelling Service of labelling items.
MAC	Minimum order/minimum billing charge Description to be provided.
MB	Multi-buy promotion (GS1 Temporary Code) A code indicating special conditions related to a multi-buy promotion.
MC	Material surcharge (special materials) Description to be provided. GS1 Description: A surcharge related to the use of special materials.
NAA	Non-returnable containers Description to be provided. GS1 Description: An allowance or charge related to the use of non-returnable containers.
PAD	Promotional allowance Description to be provided. GS1 Description: An allowance related to a promotion.
PAE	Promotional discount Description to be provided. GS1 Description: A discount related to a promotion.
PAR	Partnership allowance (GS1 Temporary Code) An allowance or charge related to the establishment and on-going maintenance of a partnership.
PC	Packing Charge for packing.
PI	Pick-up allowance Description to be provided. GS1 Description: An allowance related to the pick up of goods.
PL	Palletizing Description to be provided. GS1 Description: An allowance or charge related to the palletization of goods.

Used Codes

PN	Pallet charge Description to be provided. GS1 Description: A charge related to the use of pallets.
QAA	Quantity surcharge Fee associated with providing goods outside "normal" quantity limits. GS1 Description: Fee associated with providing goods outside "normal" quantity limits.
QD	Quantity discount Description to be provided. GS1 Description: A discount related to the purchase of a specified quantity.
RAA	Rebate Description to be provided. GS1 Description: A rebate is the refund of part of an amount already paid for a product or service.
RAD	Returnable container Description to be provided. GS1 Description: An allowance or charge related to the use of returnable containers.
RAE	Resellers discount Description to be provided.
RCH	Return handling (GS1 Temporary Code) An allowance or charge related to the handling of returns.
SER	Service charge (GS1 Temporary Code) A charge related to the provision of a guarantee.
SH	Special handling service Description to be provided. GS1 Description: An allowance or charge related to the provision of special handling services.
TAE	Truckload discount Description to be provided. GS1 Description: A discount associated with the purchase or delivery of full trucks of a product or products.
TD	Trade discount Description to be provided. GS1 Description: A standard trade discount.
TX	Tax Contribution levied by an authority.

Used Codes

TZ	Temporary allowance Description to be provided. GS1 Description: An allowance which is available on a temporary basis.
VAB	Volume discount Discount offered based on the amount of purchase.
WHE	Wholesaling discount (GS1 Temporary Code) A special discount related to the purchase of products through a wholesaler.
X01	Allowance Global (GS1 Temporary Code) A global allowance is applied.
X02	Charge Global (GS1 Temporary Code) A global charge is applied.
X03	Consolidated (GS1 Temporary Code) A charge is consolidated.
X04	Lump sum (GS1 Temporary Code) A lump sum charge applied.
X05	Markup for small volume purchases (GS1 Temporary Code) A mark up is applied for small volume purchases.
X21	Special agreement (GS1 Temporary Code) Charge or allowance which relates to a special agreement.
X22	Bank charges information (GS1 Temporary Code) Charges not included in the total charge amount.
X23	Transfer commission (GS1 Temporary Code) Fee for the transfer of transferable documentary credits.
X29	Minimum order not fulfilled charge (GS1 Temporary Code) Charge levied because the minimum order quantity could not be fulfilled.
X30	Point of sales allowance (GS1 Temporary Code) Allowance for reaching or exceeding an agreed sales threshold at the point of sales.
X31	Remittance (GS1 Temporary Code) Charge or allowance related to the service of a payment carried out with a cheque from a city different to the city where the beneficiary has the account.
X32	National consignment (GS1 Temporary Code) Charge or allowance which relates to the service of a payment carried out outside the city where the account was opened.
X33	Local consignment (GS1 Temporary Code) Charge or allowance which relates to the service of a payment carried out within the city where the account was opened.

Used Codes

X40	Allowance/charge regulated by law (GS1 Temporary Code) An allowance/charge related to a regulatory requirement.
XAA	Combine all same day shipment Description to be provided. GS1 Description: An allowance or charge related to the combination of all same day shipments.
7233	Packaging related description code Code specifying information related to packaging.
1	Product ingredients not marked on package The ingredients of the product are not marked on the packaging of the product.
2	Product price not marked on packaging The product price is not marked on the packaging of the product.
3	Product best before date not marked on product package The product best before date is not marked on the packaging of the product.
4	Package not marked recyclable Package is not marked as recyclable.
5	Promotional details marked A code indicating that promotional details have been marked on the package.
7	Sell-by date marked on package The package is marked with the last date on which the item may be sold.
8	Use-by date marked on package The package is marked with the last date on which the item may be used.
9	Packaging / manufacturing date marked on package The package is marked with the date of the packaging or manufacturing of the item.
10	No freshness date marked on package Package is not marked with any kind of date indicating freshness, such as use-by, best before or packaging date.
31	Package best before date marked Package is marked with the product best before date.
32	Package marked recyclable The package is marked recyclable.
33	Package marked returnable The package is marked returnable.
50	Package barcoded EAN-13 or EAN-8 The package is barcoded with EAN-13 or EAN-8 code.

Used Codes

51	Package barcoded ITF-14 The package is barcoded with ITF-14 code.
52	Package barcoded UCC or EAN-128 The package is barcoded with UCC or EAN-128 code.
53	Package price marked The package is marked with the price.
54	Product ingredients marked on package The ingredients of the product contained in a package are marked on that package.
64	Package never EPC tagged. The package will never be tagged with an EPC (Electronic Product Code) transponder.
65	Package sometimes EPC tagged The package will sometimes be tagged with an EPC (Electronic Product Code) transponder.
78	Package bar-coded and EPC tagged The package is bar-coded and tagged with an EPC (Electronic Product Code) transponder.
79	Package EPC tagged only The package is tagged with an EPC (Electronic Product Code) transponder only.
80	Marked with "display until date" Package is marked with the date by which the product should be removed from the display location.
81	Package marked with a variable measure barcode The package is marked with a variable measure barcode.
82	Package marked with fixed measure barcode The package is marked with a fixed measure barcode.
LAB	Labeled according to General GS1 Specifications for clothing and fashion accessories (GS1 Temporary Code) The item is labeled according to the General GS1 Specifications for clothing and fashion accessories.
NAB	Not labeled acc. to GS1 (GS1 Temporary Code) Specifications for clothes and fashion accessoires
NBR	Not barcoded (GS1 Temporary Code) The package is not barcoded.
RL1	Peg hole round 1 (GS1 Temporary Code) The item's packaging has a round peg hole. (European norm DIN EN 13010: 2003 (substitute for DIN 55512-1:1984-12))

Used Codes

SL1	Peg hole slot hole 1 (GS1 Temporary Code) The item's packaging has a slot peg hole of type 1. (European norm DIN EN 13010:2003 (substitute for DIN 55512-1:1984-12))
SL3	Peg hole slot hole 3 (GS1 Temporary Code) The item's packaging has a slot peg hole of type 3. (European norm DIN EN 13010:2003 (substitute for DIN 55512-1:1984-12))
X01	Composite Component A (GS1 Temporary Code) Packaging marked with CC-A barcode.
X02	Composite Component B (GS1 Temporary Code) Packaging marked with CC-B barcode.
X03	Composite Component C (GS1 Temporary Code) Packaging marked with CC-C barcode.
X04	RSS-14 (GS1 Temporary Code) Packaging marked with RSS-14 (GS1 DataBar) symbology.
X05	RSS-14 Stacked (GS1 Temporary Code) Packaging marked with RSS-14 (GS1 DataBar) stacked symbology.
X06	RSS-14 Staked omnidirectional (GS1 Temporary Code) Packaging marked with RSS-14 (GS1 DataBar) stacked omnidirectional symbology.
X07	RSS-14 Truncated (GS1 Temporary Code) Packaging marked with RSS-14 (GS1 DataBar) truncated symbology.
X08	RSS expanded (GS1 Temporary Code) Packaging marked with RSS (GS1 DataBar) expanded symbology.
X09	RSS expanded truncated (GS1 Temporary Code) Packaging marked with RSS (GS1 DataBar) expanded truncated symbology.
X10	RSS limited (GS1 Temporary Code) Packaging marked with RSS (GS1 DataBar) limited symbology.
X11	UPC A symbol (GS1 Temporary Code) Packaging marked with UPC A symbol.
X12	UPC E Symbol (GS1 Temporary Code) Packaging marked with UPC E symbol.
X13	EANUCC 14 Symbol (GS1 Temporary Code) Packaging marked with EAN UCC 14 symbology.
X14	Package not marked returnable (GS1 Temporary Code) Packaging marked with EAN UCC 14 symbology.
X15	Gift wrapping (GS1 Temporary Code) Trade item is packaged in a gift wrapping.

Used Codes

X16	Greeting card (GS1 Temporary Code) Trade item is accompanied by a greeting card.
7405	Object identification code qualifier Code qualifying the identification of an object.
AW	Serial shipping container code A single unique serial number which identifies shipping containers or shipping packages. GS1 Note: Replaces code BJ.
BJ	Serial shipping container code A single unique serial number which identifies shipping containers or shipping packages. GS1 Note: Code marked for deletion. Use AW instead. GS1 Description: A single unique serial number which identifies shipping containers or shipping packages.
BN	Serial number Identification number of an item which distinguishes this specific item out of a number of identical items.
8051	Transport stage code qualifier Code qualifying a specific stage of transport.
1	Inland transport Transport by which goods are moved from or to the frontier, or between inland points.
10	Pre-carriage transport Transport by which the goods are moved prior to their main carriage transport.
11	At border Transport by which goods are moved to the Customs frontier.
12	At departure Transport by which goods are moved from the place of departure.
13	At destination Transport by which goods are moved at the place of destination.
20	Main-carriage transport The primary stage in the movement of cargo from the point of origin to the intended destination.
25	Delivery carrier all transport Carrier responsible from the point of origin to the final delivery destination.
30	On-carriage transport Transport by which the goods are moved after the main carriage transport.

Used Codes

I	Origin switch carrier (GS1 Temporary Code) Carrier taking responsibility for the goods from the carrier which has transported them from their point of origin.
8067	Transport mode name code Code specifying the name of a mode of transport. Notes: 1. Use UN/ECE Recommendation No 19.
0	Transport mode not specified Transport mode has not been specified. Notes: 1) This code can be used when the mode is not known or when information on is not available at the time of issuing the document concerned.
1	Maritime transport Transport of goods and/or persons is by sea.
2	Rail transport Transport of goods and/or persons is by rail.
3	Road transport Transport of goods and/or persons is by road.
4	Air transport Transport of goods and/or persons is by air.
5	Mail Method to convey goods is by mail. Notes: 1) This code is provided for practical reasons, despite the fact that mail is not a genuine mode of transport. In many countries, the value of merchandise exported by mail is considerable, but the exporter or importer concerned would be unable to state by which mode postal items had been conveyed.
6	Multimodal transport Method to convey goods and/or persons is by multimodal transport. Notes: 1) This code is provided for practical reasons, despite the fact that multimodal transport is not a genuine mode of transport. It can be used when goods are carried by at least two different modes from a place at which the goods are taken in charge by a transport operator to a place designated for delivery, on the basis of one transport contract. (Operations of pick-up and delivery of goods carried out in the performance of a single mode of transport, as defined in such a contract, shall not be considered as multimodal transport).

Used Codes

7	Fixed transport installations Transport of item is via a fixed transport installation.
	Notes: 1) This code applies to installations for continuous transport such as pipelines, ropeways and electric power lines.
8	Inland water transport Transport of goods and/or persons is by inland water transport.
9	Transport mode not applicable The mode of transport is not applicable.
100	Courier service (GS1 Temporary Code) A courier service used to collect and deliver a consignment to its destination.
8101	Transit direction indicator code Code specifying the direction of transport.
BS	Buyer to supplier Self explanatory. GS1 Description: Self explanatory.
SB	Supplier to buyer The transport from the seller to the buyer. GS1 Description: The transport from the seller to the buyer.
8179	Transport means description code Code specifying the means of transport.
1	Barge chemical tanker A barge equipped to transport liquid chemicals.
9	Exceptional transport Transport for which common characteristics are not applicable (e.g. big transformers requiring special wagons, special tackles, special routing etc.).
12	Ship tanker A large vessel equipped to transport liquids.
13	Ocean vessel
19	Tip-up truck A truck capable of tipping up in order to deliver its load.
20	Furniture truck A truck used explicitly for the conveyance of furniture.
21	Rail tanker A rail wagon equipped to transport liquids.

Used Codes

22	Rail silo tanker Self explanatory. Notes: This code value will be removed effective with directory D.04B.
23	Rail bulk car A rail wagon equipped to transport bulk cargo.
26	Tip-up articulated truck An articulated truck capable of tipping up in order to deliver its load.
28	Refrigerated truck and trailer A combined truck and trailer equipped to maintain refrigerated temperatures. GS1 Description: A truck and trailer capable of transporting refrigerated goods.
29	Freezer truck and trailer A combined truck and trailer equipped to maintain freezing temperatures. GS1 Description: A truck and trailer capable of transporting frozen goods.
30	Tautliner 25 tonne, combined with 90 cubic meter trailer with removable roof A truck with non-ridged sides, 25 tonne capacity combined with a 90 cubic meter trailer with removable roof.
31	Truck An automotive vehicle for hauling goods.
32	Road tanker An over-the-road tank trucker or trailer.
35	Truck/trailer with tilt A truck and trailer combination with a tilting capability. GS1 Description: A truck/trailer fitted with a tilting mechanism.
40	Truck with opening floor A truck with an opening floor mechanism which is used to discharge the cargo.
41	Freezer truck A truck equipped to maintain freezing temperatures.
42	Isothermic truck A truck equipped to maintain controlled temperatures.
43	Refrigerated truck A truck equipped to maintain refrigerated temperatures. GS1 Description: A truck capable of transporting refrigerated goods.

Used Codes

44	Freezer van A small rigid covered vehicle for conveying frozen goods. GS1 Description: A van capable of transporting frozen goods.
45	Isothermic van A small rigid covered vehicle for conveying temperature controlled goods. GS1 Description: A van capable of transporting temperature controlled goods.
46	Refrigerated van A small rigid covered vehicle for conveying refrigerated goods. GS1 Description: A van capable of transporting refrigerated goods.
47	Bulk truck A truck suitable for transporting bulk goods.
48	Van A small vehicle suitable for carrying small volume loads.
73	Train with more than one and less than 20 wagons A train with more than one and less than 20 wagons used to carry goods.
74	Train with 20 or more wagons A train with 20 or more wagons used to carry goods.
77	Freezer truck and isothermic trailer A combined freezer truck and isothermic trailer.
78	Isothermic truck and isothermic trailer A truck and a trailer equipped to maintain controlled temperatures.
79	Refrigerated truck and isothermic trailer A combined refrigerated truck and isothermic trailer.
80	Freezer truck and refrigerated trailer A combined freezer truck and refrigerated trailer.
81	Isothermic truck and refrigerated trailer A combined isothermic truck and refrigerated trailer.
82	Rigid truck with tank and tank trailer A combined rigid truck with tank and tank trailer.
83	Bulk truck and tank trailer A combined truck capable of carrying liquids or bulk goods and a tank trailer.
84	Rigid truck with tank and bulk trailer A combined rigid truck with tank and a trailer capable of carrying liquids or bulk goods.
85	Bulk truck and bulk trailer A combined truck and a trailer both capable of carrying liquids or bulk goods.

Used Codes

86	Tautliner truck and extendable trailer A combined tautliner truck and extendable trailer.
87	Tautliner truck with removable roof and extendable trailer A combined tautliner truck with removable roof and extendable trailer.
88	Truck with opening floor and extendable trailer A combined truck with opening floor and extendable trailer.
89	Bulk truck and extendable trailer A combined truck capable of carrying liquids or bulk goods and an extendable trailer.
90	Isothermic truck and freezer trailer A combined isothermic truck and freezer trailer.
91	Refrigerated truck and freezer trailer A combined refrigerated truck and freezer trailer.
92	Tip-up truck and gondola trailer A combined tip-up truck and gondola trailer. A gondola trailer is a split level trailer suitable for the transport of heavy machinery.
93	Tautliner truck and gondola trailer A combined tautliner truck and gondola trailer. A gondola trailer is a split level trailer suitable for the transport of heavy machinery.
94	Tautliner truck with removable roof and gondola trailer A combined tautliner truck with removable roof and gondola trailer. A gondola trailer is a split level trailer suitable for the transport of heavy machinery.
95	Truck with opening floor and gondola trailer A combined truck with opening floor and gondola trailer. A gondola trailer is a split level trailer suitable for the transport of heavy machinery.
96	Bulk truck and gondola trailer A combined truck capable of carrying liquids or bulk goods and a gondola trailer. A gondola trailer is a split level trailer suitable for the transport of heavy machinery.
97	Tip-up truck and extendable gondola trailer A combined tip-up truck with extendable gondola trailer. An extendable gondola trailer is a trailer fitted with a rear axle which can be extended to cater for variable length and is suitable for the transport of heavy machinery.
98	Tautliner truck and extendable gondola trailer A combined tautliner truck and extendable gondola trailer. An extendable gondola trailer is a trailer fitted with a rear axle which can be extended to cater for variable length and is suitable for the transport of heavy machinery.

Used Codes

99	Tautliner truck with removable roof and extendable gondola trailer A combined tautliner truck with removable roof and extendable gondola trailer. An extendable gondola trailer is a trailer fitted with a rear axle which can be extended to cater for variable length and is suitable for the transport of heavy machinery.
100	Truck with opening floor and extendable gondola trailer A combined truck with opening floor and extendable gondola trailer. An extendable gondola trailer is a trailer fitted with a rear axle which can be extended to cater for variable length and is suitable for the transport of heavy machinery.
101	Bulk truck and extendable gondola trailer A combined truck capable of carrying liquids or bulk goods and a extendable gondola trailer. An extendable gondola trailer is a trailer fitted with a rear axle which can be extended to cater for variable length and is suitable for the transport of heavy machinery.
102	Tip-up truck and trailer with opening floor A combined tip-up truck and trailer with opening floor.
103	Tautliner truck and trailer with opening floor A combined tautliner truck and trailer with opening floor.
104	Tautliner truck with removable roof and trailer with opening floor A combined tautliner truck with removable roof and trailer with opening floor.
106	Bulk truck and trailer with opening floor A combined truck capable of carrying liquids or bulk goods and a trailer with opening floor.
3138	Armoured vehicle Automotive vehicle designed with fortified body for enhanced protection.
10E	Tautliner 25t (GS1 Temporary Code) A 25t Tautliner truck/trailer.
11E	Tautliner 25t with removable roof (GS1 Temporary Code) A 25t Tautliner truck/trailer with removable roof.
12E	Articulated flat lorry 25t (GS1 Temporary Code) An articulated flat lorry capable of carrying loads of 25 tonnes.
13E	Articulated flat lorry 24t with crane 10m (GS1 Temporary Code) An articulated flat lorry with a 10 meter crane capable of carrying loads of 24 tonnes.
14E	Articulated flat lorry 24t with crane 15m (GS1 Temporary Code) An articulated flat lorry with a 15 meter crane capable of carrying loads of 24 tonnes.
15E	Articulated flat lorry 24t with crane 18m (GS1 Temporary Code) An articulated flat lorry with a 18 meter crane capable of carrying loads of 24 tonnes.

Used Codes

16E	Articulated flat lorry 10t (GS1 Temporary Code) An articulated flat lorry capable of carrying loads of 10 tonnes.
17E	Tautliner 25t with trailer 90m3 (GS1 Temporary Code) A 25t Tautliner truck/trailer with a 90 m3 trailer.
18E	Tautliner 25t with trailer 120m3 (GS1 Temporary Code) A 25t Tautliner truck/trailer with a 120 m3 trailer.
19E	Flat lorry with trailer and crane 10m (GS1 Temporary Code) An flat lorry with a trailer and a 10 meter crane.
20E	Articulated lorry with tank (GS1 Temporary Code) An articulated lorry fitted with a tank capable of carrying liquids or bulk goods..
21E	Flat lorry 15t (GS1 Temporary Code) A flat lorry capable of carrying loads of 15 tonnes.
22E	Flat lorry 25t with crane (GS1 Temporary Code) An flat lorry fitted with a crane and capable of carrying loads of 25 tonnes.
27E	Isothermic trailer (GS1 Temporary Code) A trailer capable of transporting temperature controlled goods.
28E	Refrigerated trailer (GS1 Temporary Code) A trailer capable of transporting refrigerated goods.
32E	Trailer (GS1 Temporary Code) A trailer suitable for transporting containerised or palletized goods.
33E	Tank trailer (GS1 Temporary Code) A tank trailer suitable for transporting liquids.
34E	Bulk trailer (GS1 Temporary Code) A trailer suitable for transporting bulk goods.
37E	Extendable trailer (GS1 Temporary Code) A trailer fitted with a rear axle which can be extended to cater for variable length loads.
38E	Dolly trailer (GS1 Temporary Code) A trailer composed of a platform mounted on an axle. The trailer is not connected directly to the truck but connected by the load.
39E	Freezer trailer (GS1 Temporary Code) A trailer suitable for transporting frozen goods.
41E	Furniture removal trailer (GS1 Temporary Code) A trailer used explicitly for the removal of furniture.
44E	Gondola trailer (GS1 Temporary Code) A split level trailer suitable for the transport of heavy machinery (e.g. earth movers).

Used Codes

45E	Extendable gondola trailer (GS1 Temporary Code) A trailer fitted with a rear axle which can be extended to cater for variable length loads and is suitable for the transport of heavy machinery (e.g. earth movers).
46E	Rigid lorry with tank (GS1 Temporary Code) A rigid lorry fitted with a tank capable of carrying liquids or bulk goods.
50E	Tautliner rigid truck (GS1 Temporary Code) A Tautliner rigid truck.
51E	Tautliner rigid truck with removable roof (GS1 Temporary Code) A Tautliner rigid truck with removable roof.
53E	Trailer with opening floor (GS1 Temporary Code) A trailer with an opening floor mechanism which is used to discharge the cargo.
54E	Train with convergent set of wagons (GS1 Temporary Code) A train with wagons coming from different despatch locations which must be grouped in order to form one train.
55E	Train with divergent set of wagons (GS1 Temporary Code) A train with wagons coming from the same despatch location which will be split in different trains because there are more than one point of delivery.
56E	Combination of a truck (length 6 m) and a trailer (length 8 m) (GS1 Temporary Code) Combination of a truck (length 6 m) and a trailer (length 8m) having a combined tonnage of between 23 and 25 tons and a loading capacity of 90m ³ .
57E	Combination of a truck (length 6 m) and a trailer (length 9 m) (GS1 Temporary Code) Combination of a truck (length 6m) and a trailer (length 9m) having a combined tonnage of between 23 and 25 tons and a loading capacity of 100m ³ .
58E	Combination of a truck and trailer with a length of 13.6m, a tonnage between 23 and 25 tons (GS1 Temporary Code) Combination of a truck and a trailer with a length of 13.6m, a tonnage between 23 and 25 tons, and a loading capacity of 80 m ³ .
59E	Rail wagon (GS1 Temporary Code) A single rail wagon used to carry goods.
77E	Furniture truck and trailer (GS1 Temporary Code) A combined truck and trailer capable of carrying furniture.
78E	Tautliner truck and furniture trailer (GS1 Temporary Code) A combined tautliner truck and furniture trailer.
79E	Tautliner truck with removable roof and furniture trailer (GS1 Temporary Code) A combined tautliner truck with removable roof and furniture trailer.

Used Codes

93E	Truck and trailer with opening floor (GS1 Temporary Code) A combined truck and a trailer with an opening floor.
95E	Tautliner truck and dolly trailer (GS1 Temporary Code) A combined tautliner truck and a dolly trailer.
96E	A tautliner truck with removable roof and a dolly trailer (GS1 Temporary Code) A combined tautliner truck with removable roof and a dolly trailer.
97E	Truck with trailer (GS1 Temporary Code) Combined truck and trailer.
98E	Truck with crane for moving goods without trailer (GS1 Temporary Code) A truck with a crane that enables to move goods, without trailer.
99E	Truck with crane for moving goods with trailer (GS1 Temporary Code) A truck with a crane that enables to move goods, with trailer.
X01	Truck with crane for lifting goods without trailer (GS1 Temporary Code) A truck with a crane that enables to lift goods, without trailer.
X02	Truck with crane for lifting goods with trailer (GS1 Temporary Code) A truck with a crane that enables to lift goods, with trailer.
X04	Courier express (GS1 Temporary Code) Use the fastest courier means possible.
X05	Road parcel express (GS1 Temporary Code) Parcel express service by road.
X06	Air freight (GS1 Temporary Code) Air freight delivery service.
X07	Surface air lifting (GS1 Temporary Code) Surface air lifting postal service.
X08	Air express (GS1 Temporary Code) Air express delivery service.
X09	Parcel post (GS1 Temporary Code) Postal service for the delivery of parcels.
X10	Mail express (GS1 Temporary Code) The express mail service of the postal service.
X11	Surface mail (GS1 Temporary Code) For non air mail international mailing.
X12	Accelerated surface mail (GS1 Temporary Code) Higher priority surface mail.
X13	Air mail (GS1 Temporary Code) Use air mail service.

Used Codes

X14	Printed matter/book post (GS1 Temporary Code) A special mailing service for printed matter or books.
X15	Parcel delivery registered (GS1 Temporary Code) Service for the delivery of registered parcels
X16	Parcel delivery express service registered (GS1 Temporary Code) Express service for the delivery of registered parcels
X3	Truck up to 3,5 tons (GS1 Temporary Code) A truck with a total weight up to 3,5 tons.
X4	Miscellaneous transport means (GS1 Temporary Code) Miscellaneous means of transport not further defined.
8395	Returnable package freight payment responsibility code Code specifying the responsibility for the freight payment for a returnable package.
1	Paid by customer Self explanatory.
2	Free Self explanatory.
3	Paid by supplier The responsibility for the freight for returning the packaging is to be paid by the supplier.
8453	Transport means nationality code Code specifying the nationality of a means of transport. Notes: 1. Use ISO 3166-1 two alpha country code.
AD	Andorra
AE	United Arab Emirates
AF	Afghanistan
AG	Antigua and Barbuda
AI	Anguilla
AL	Albania
AM	Armenia
AO	Angola
AQ	Antarctica
AR	Argentina
AS	American Samoa

Used Codes

AT	Austria
AU	Australia
AW	Aruba
AX	Åland Islands
AZ	Azerbaijan
BA	Bosnia and Herzegovina
BB	Barbados
BD	Bangladesh
BE	Belgium
BF	Burkina Faso
BG	Bulgaria
BH	Bahrain
BI	Burundi
BJ	Benin
BL	Saint Barthélemy
BM	Bermuda
BN	Brunei Darussalam
BO	Bolivia (Plurinational State of)
BQ	Bonaire, Sint Eustatius and Saba
BR	Brazil
BS	Bahamas
BT	Bhutan
BV	Bouvet Island
BW	Botswana
BY	Belarus
BZ	Belize
CA	Canada
CC	Cocos (Keeling) Islands
CD	Congo, Democratic Republic of
CF	Central African Republic
CG	Congo
CH	Switzerland
CI	Cote D'Ivoire

Used Codes

CK	Cook Islands
CL	Chile
CM	Cameroon
CN	China
CO	Colombia
CR	Costa Rica
CU	Cuba
CV	Cape Verde
CW	Curaçao
CX	Christmas Island
CY	Cyprus
CZ	Czechia
DE	Germany
DJ	Djibouti
DK	Denmark
DM	Dominica
DO	Dominican Republic
DZ	Algeria
EC	Ecuador
EE	Estonia
EG	Egypt
EH	Western Sahara
ER	Eritrea
ES	Spain
ET	Ethiopia
FI	Finland
FJ	Fiji
FK	Falkland Islands (Malvinas)
FM	Micronesia (Federated States of)
FO	Faroe Islands
FR	France
GA	Gabon
GB	United Kingdom of Great Britain and Northern Ireland

Used Codes

GD	Grenada
GE	Georgia
GF	French Guiana
GG	Guernsey
GH	Ghana
GI	Gibraltar
GL	Greenland
GM	Gambia
GN	Guinea
GP	Guadeloupe
GQ	Equatorial Guinea
GR	Greece
GS	South Georgia and the South Sandwich Islands
GT	Guatemala
GU	Guam
GW	Guinea-Bissau
GY	Guyana
HK	Hong Kong
HM	Heard Island and McDonald Islands
HN	Honduras
HR	Croatia
HT	Haiti
HU	Hungary
ID	Indonesia
IE	Ireland
IL	Israel
IM	Isle Of Man
IN	India
IO	British Indian Ocean Territory
IQ	Iraq
IR	Iran (Islamic Republic of)
IS	Iceland
IT	Italy

Used Codes

JE	Jersey
JM	Jamaica
JO	Jordan
JP	Japan
KE	Kenya
KG	Kyrgyzstan
KH	Cambodia
KI	Kiribati
KM	Comoros
KN	Saint Kitts and Nevis
KP	Korea (Democratic People'S Republic of)
KR	Korea, Republic of
KW	Kuwait
KY	Cayman Islands
KZ	Kazakhstan
LA	Lao People'S Democratic Republic
LB	Lebanon
LC	Saint Lucia
LI	Liechtenstein
LK	Sri Lanka
LR	Liberia
LS	Lesotho
LT	Lithuania
LU	Luxembourg
LV	Latvia
LY	Libya
MA	Morocco
MC	Monaco
MD	Moldova, Republic of
ME	Montenegro
MF	Saint Martin (French Part)
MG	Madagascar
MH	Marshall Islands

Used Codes

MK	Macedonia, the Former Yugoslav Republic of
ML	Mali
MM	Myanmar
MN	Mongolia
MO	Macao
MP	Northern Mariana Islands
MQ	Martinique
MR	Mauritania
MS	Montserrat
MT	Malta
MU	Mauritius
MV	Maldives
MW	Malawi
MX	Mexico
MY	Malaysia
MZ	Mozambique
NA	Namibia
NC	New Caledonia
NE	Niger
NF	Norfolk Island
NG	Nigeria
NI	Nicaragua
NL	Netherlands
NO	Norway
NP	Nepal
NR	Nauru
NU	Niue
NZ	New Zealand
OM	Oman
PA	Panama
PE	Peru
PF	French Polynesia
PG	Papua New Guinea

Used Codes

PH	Philippines
PK	Pakistan
PL	Poland
PM	Saint Pierre and Miquelon
PN	Pitcairn
PR	Puerto Rico
PS	Palestine, State of
PT	Portugal
PW	Palau
PY	Paraguay
QA	Qatar
RE	Reunion
RO	Romania
RS	Serbia
RU	Russian Federation
RW	Rwanda
SA	Saudi Arabia
SB	Solomon Islands
SC	Seychelles
SD	Sudan
SE	Sweden
SG	Singapore
SH	Saint Helena, Ascension and Tristan da Cunha
SI	Slovenia
SJ	Svalbard and Jan Mayen
SK	Slovakia
SL	Sierra Leone
SM	San Marino
SN	Senegal
SO	Somalia
SR	Suriname
SS	South Sudan
ST	Sao Tome and Principe

Used Codes

SV	El Salvador
SX	Sint Maarten (Dutch part)
SY	Syrian Arab Republic
SZ	Swaziland
TC	Turks and Caicos Islands
TD	Chad
TF	French Southern Territories
TG	Togo
TH	Thailand
TJ	Tajikistan
TK	Tokelau
TL	Timor-Leste
TM	Turkmenistan
TN	Tunisia
TO	Tonga
TR	Turkey
TT	Trinidad and Tobago
TV	Tuvalu
TW	Taiwan, Province of China
TZ	Tanzania, United Republic of
UA	Ukraine
UG	Uganda
UM	United States Minor Outlying Islands
US	United States of America
UY	Uruguay
UZ	Uzbekistan
VA	Holy See
VC	Saint Vincent and the Grenadines
VE	Venezuela (Bolivarian Republic of)
VG	Virgin Islands, British
VI	Virgin Islands, U.S.
VN	Viet Nam
VU	Vanuatu

Used Codes

WF	Wallis and Futuna
WS	Samoa
YE	Yemen
YT	Mayotte
ZA	South Africa
ZM	Zambia
ZW	Zimbabwe
9213	Duty regime type code Code specifying a type of duty regime.
1	Origin subject to EC/EFTA preference Self explanatory.
2	Origin subject to other preference agreement Self explanatory.
3	No preference origin Origin of the product is not subject to any preference.
8	Excluded origin Origin of the product is excluded.
9	Imposed origin Origin of the product is imposed.

Example

UNA:+.?' '
UNA:+.?' '

UNB+UNOA:3+4012345000009:14:1+4000004000002:14:4000004000099+021013:1043
+12345555+REF:AA++A+1+EANCOM-DISI+1 '
UNB+UNOA:3+5412345678908:14+8798765432106:14+020102:
1000+12345555++++EANCOMREF 52'

UNH+1+INVOIC:D:01B:UN:EAN011 '
UNH+1+INVOIC:D:01B:UN:EAN011'

BGM+380:::METERED SERVICES INVOICE.+432097:::X+9+NA '
BGM+380+432097+9 '
BGM+82+MSI5422'

DTM+137:19931008:102 '
DTM+137:20021008:102 '
DTM+35:200210151430:203'

PAI+1:20:42:25:6:1 '
PAI+:::42'

ALI+GB+1+1+1+1+1+1 '
ALI+EU'

FTX+ZZZ+1+001:23:6+MESSAGE HERE:FREE TEXT:FREE TEXT:FREE TEXT:FREE TEXT+
EN '
FTX+PUR+1+001:::91'

RFF+AAB:2554125 '
RFF+ALL:252 '
RFF+ON:ORD9523'

DTM+171:19930804:102 '
DTM+171:20020804:102'

NAD+BO+5412345000013:::9+X:::X+P1:P2:P3:P4:P5:1+S1:S1:S1:X+DUB+IRL:23:2:
X+4+IE '
NAD+BY+5412345000020:::9 '
NAD+SU+4012345500004:::9 '
NAD+DP+5412345000013:::9'

FII+PB+1:2:AAA:EUR+BK:25:5:1:25:5:1:1+AD '
FII+RB+994-3277711:NGEISS+KREDBEBB:25:5'

RFF+VA:VR12345 '
RFF+VA:VR12345'

CTA+AD+A:MARK CARTER '
CTA+AD+:MARK CARTER'

COM+00448132445322:TE '
COM+00448132445322:TE'

TAX+5+VAT:23:2:A+A:23:2+1+1:23:2:12.5:1:23:2+S+1 '
TAX+7+VAT++++:::21+S'

MOA+124:1 '
MOA+124:154.54'

CUX+2:EUR:4+3:EUR:4:1+49.34'

Example

CUX+2:EUR:4'
CUX+2:EUR:4+3:USD:11+0.90243'

DTM+134:19931010:102'
DTM+134:20021010:102'

PAT+1+1:23:6:1:1+5:3:D:30'
PAT+1++5:3:D:30'

DTM+7:19930831:102'
DTM+13:20020831:102'

PCD+1:95.5:13:23:6'
PCD+15:2.5:13'

MOA+21:100'
MOA+21:100'

PAI+1:10:42:23:2:1'
PAI+::42'

FII+RB+1:2:AAA:EUR+BK:25:5:1:25:5:1:1+AD'
FII+RB+994-3277711+KREDBEBB:25:5'

TDT+13+10032+3+31:A+ABC123:23:9:EX+SB++524SQ744:23:6:A:GB'
TDT+20++30+31'

LOC+1+X:23:9:X+:23:9:X+:23:9:X'
LOC+5+5412345678908::9'

DTM+2:X:2'
DTM+132:20010606:102'

RFF+AAB:2554125'
TOD+6+PP+01E:23:6:12:1'
TOD+3++CIF:2E:9'

LOC+1+1:23:3:1'
LOC+1+BE-BRU'

PAC+1+1:1:1+AE:23:2:1++1'
PAC+6++CR'

ALC+A+ALL1234:69+6+1+AJ:132:6:1:1'
ALC+C++6++FC'

QTY+1:152:KGM'
QTY+1:152'

PCD+1:1.45:13:23:2'
PCD+1:1.45:13'

MOA+8:125.00'
MOA+8:125.00'

RTE+1:500:100:KGM'
RTE+1:500:100'

TAX+7+VAT:23:6:1+1:23:6+1+1:23:6:21:1:23:6+S+12'
TAX+7+VAT+++:::21+S'

MOA+1:1.23'
MOA+124:154.76'

Example

AJT+3'

AJT+3'

LIN+1++4000862141404:SRV+1:1'

LIN+1++4000862141404:SRV'

PIA+5+ABC5343:SA:23:92+1:IN:23:6+2:IN:23:6+3:IN:23:6+4:IN:23:6'

PIA+1+ABC5343:IN'

PIA+4+5412345111184:SRV'

PIA+5+2209953C001L:AC'

IMD+C+2:23:9+CU:23:9:BEXTARTAR:B:AA'

IMD+C++TU::9'

IMD+F++:::CORN CRUNCHIES:CASE'

MEA+PD+AAA:4+KWT:5219:4000:7000:1'

MEA+PD+HT+MMT:500'

MEA+PD+LN+MMT:200'

MEA+PD+WD+MMT:100'

QTY+12:8354:C0'

QTY+47:40'

ALI+GB+1+1+1+1+1+1'

ALI+EU'

DTM+35:19930801:102'

DTM+35:20020801:102'

GIN+BN+X:X+X:X+X:X+X:X+X:X'

GIN+BN+AS-1299:AS-1350'

QVR+40:12+BP+AJT:23:9:1'

QVR+-20:21'

FTX+CHG+1+002:132:9+A:B:C:D:E+EN'

FTX+ZZZ+1+002::91'

MOA+203:14562.32:GBP:4'

MOA+203:580'

PAT+1++5:1:D:12'

PAT+7++5:3:D:90'

DTM+13:19930830:102'

DTM+13:20020830:102'

PCD+7:1.5'

PCD+12:2.5'

MOA+8:12.50'

MOA+201:100'

PRI+AAA:1235.20:CT:AAE:1:KWT'

PRI+AAA:14.50:CA'

PRI+AAB:25:CT'

PRI+AAE:2.56:CA:SRP'

PRI+AAF:4.20:CA:RTP'

APR+CR+123456789012:A+X29:::2:ABCD'

APR+MF+0.95:A+X29'

Example

RFF+AAK:8306:1'
RFF+AAK:8306'

DTM+171:19930802:102'
DTM+171:20020802:102'

PAC+1+1:1:3+AE:23:6:A++1'
PAC+++CR++3'

MEA+AAB+A:3+KGM:2:2:2:1'
MEA+PD+AAA:4+KGM:400'

PCI+39+1:12:1:1:1:1:1:1:1:1'
PCI+39'

GIN+AW+1:1+1:1+1:1+1:1+12:1'
GIN+AW+354123450000000014'

LOC+7+401234550000:23:9:A+:23:6:1'
LOC+7+4012345500004::9'

QTY+131:1234:KWT'
QTY+131:12'

DTM+35:19930602:102'
DTM+35:20020602:102'

TAX+7+VAT:23:6:21+1234:23:6+A+A:23:6:12.5:1:23:6+S+123'
TAX+7+VAT+++:::21+S'

MOA+124:123.52'
MOA+124:121.80'

NAD+DP+5412345000013:23:9+X:::X+P:P1:P2:P3:P4:1+S:S1:S2:X+C+I:23:2:X+1+
IE'
NAD+DP+5412345000013::9'

RFF+YC1:DN8523'
RFF+VA:VR85231142'

ALC+A+DISC920802:69+2+1+CAC:23:6:1:1'
ALC+A+++1'

ALI+GB+1+1+1+1+1+1'
ALI+++6'

DTM+140:X:2'

QTY+1:12:KGM'
QTY+1:12'

PCD+1:0.75:1:23:6'
PCD+1:0.75'

MOA+8:12.20'
MOA+204:12.20'

RTE+1:1.25:1:KWT'
RTE+1:1.25'

TAX+7+VAT:23:6:1+1:23:6+1+1:23:6:12.5:1:23:6+S+2'
TAX+7+VAT+++:::21+S'

MOA+1:1'

Example

MOA+124:21.80'

TDT+1+1+0+1:1+1:23:9:1+BS++1:23:9:1:IE'

TDT+20++30+31'

TOD+3+DF+01E:23:2:A:A'

TOD+3++CIF:2E:9'

LOC+1+A:23:3:A'

LOC+1+BE-BRU'

UNS+S'

UNS+S'

CNT+1:120:ACR'

CNT+2:120'

MOA+9:12563.20:AED:1'

MOA+86:45612.20'

RFF+PQ:1'

RFF+PQ:4452'

DTM+171:19930806:102'

DTM+171:20020802:102'

TAX+7+VAT:23:6:1+1:23:6+1+1:23:6:12.5:1:23:6+S+1'

TAX+7+VAT+++:::21+S'

TAX+7+VAT+++:::12.5+S'

TAX+7+VAT+++:::15+S'

MOA+176:15243.32:::18'

MOA+176:15243.32'

ALC+A+21:1+1++AA:23:6:1:1'

ALC+A+21108'

ALI+GB+1+1+1+1+1+1'

ALI+++6'

MOA+8:6583.49'

MOA+131:6583.49'

UNT+91+1'

UNT+103+1'

UNZ+1+12345555'

UNZ+5+12345555'
